



# nodegrid

User Guide v5.6

## Contents

About the Nodegrid v5.6 User Guide.....	1
Notifications .....	1
Credits .....	2
Product Overview .....	2
Nodegrid Serial Console .....	2
Nodegrid Serial Console - S Series .....	2
Nodegrid Serial Console - R Series.....	5
Nodegrid Serial Console - T Series.....	7
Nodegrid Net Services Router Family.....	9
Nodegrid Net Services Router.....	10
Nodegrid Net Services Router Expansion Modules.....	12
Nodegrid Gate SR .....	15
Nodegrid Hive SR.....	19
Nodegrid Bold SR.....	22
Nodegrid Link SR .....	26
Nodegrid Mini SR .....	30
Nodegrid Manager .....	33
Installation .....	34
Hardware Installation .....	34
Shipping Box Contents.....	34
Installation of Modules for Nodegrid Net Services Router .....	35
M.2 Cellular Antenna Placement .....	36
Device Power Connections .....	37
Rack Mounting .....	41
Network Connection .....	45
Power Cord(s) Connection .....	45
Connect Devices.....	45
Serial Devices .....	45
IP Devices .....	46
Connect to a Nodegrid Device .....	46
Connect to the Console Port .....	47
ETH0 Connection .....	47
WiFi Connection .....	47
Bluetooth® Connection .....	48
KVM Port Connection .....	48
I/O Ports (GPIO).....	48
Import / Export Configuration .....	49
Import Configuration Settings .....	49
Export Configuration Settings.....	50
Nodegrid Manager Installation .....	50
Create a VMware Virtual Machine .....	50
Install Nodegrid Manager .....	53
Enroll Nodegrid Manager to ZPE Cloud .....	55
System Profile.....	56
Gateway Profile .....	57
Out of Band Profile .....	57
Initial Network Configuration .....	58
Access the CLI Window.....	58
Identify Current IP Address .....	58
Define Static IP Address.....	59
Configure Loopback Address .....	60
WiFi Module .....	61

- General Information..... 63
  - User Interfaces..... 63
    - WebUI Banner..... 63
    - Configuration Updates..... 66
    - CLI Interface..... 66
    - Shell Access..... 68
  - Access to Devices..... 68
    - Device Sessions..... 68
    - CLI Device Sessions..... 71
  - Search Functionality..... 72
    - Device Search..... 72
    - Global Search..... 75
- Access Section..... 75
  - Table tab..... 76
    - Function Descriptions..... 77
    - View Device Details..... 80
    - Manage Power..... 81
  - Tree tab..... 83
    - View Column Branches..... 83
  - Node tab..... 85
  - Map tab..... 86
  - Overview tab..... 86
  - Image tab..... 89
- Tracking Section..... 89
  - Open Sessions tab..... 89
    - Sessions Table sub-tab..... 89
    - Devices Table sub-tab..... 90
  - Event List tab..... 90
    - Statistics sub-tab..... 90
    - Events sub-tab..... 91
  - System Usage tab..... 95
    - Memory Usage sub-tab..... 96
    - CPU Usage sub-tab..... 96
    - Disk Usage sub-tab..... 96
  - Discovery Logs tab..... 96
    - Manage Logs..... 97
  - Network tab..... 97
    - Interface sub-tab..... 97
    - Switch Interfaces sub-tab..... 98
    - MSTP sub-tab (Net SR only)..... 99
    - LLDP sub-tab..... 99
    - Routing Table sub-tab..... 99
    - MAC Table sub-tab..... 100
    - IPsec sub-tab..... 100
    - Wireguard sub-tab..... 100
    - Hotspot sub-tab..... 101
    - QoS sub-tab..... 101
    - DHCP sub-tab..... 101
    - Flow Exporter sub-tab..... 102
  - Devices tab..... 102
    - Serial Statistics sub-tab..... 102
    - USB devices sub-tab..... 103
    - Bluetooth sub-tab..... 105
    - Wireless Modem sub-tab..... 105

GPS sub-tab .....	108
GEO Fence sub-tab .....	108
Scheduler tab .....	108
HW Monitor tab .....	109
Thermal sub-tab .....	109
Power sub-tab .....	109
USB Sensors sub-tab .....	109
I/O Ports (GPIO) sub-tab (Gate SR/Link SR only) .....	112
ZPE Cloud tab .....	113
SD-WAN tab .....	113
Underlay sub-tab .....	114
Overlay sub-tab .....	115
System Section .....	115
License tab .....	115
Manage Licenses .....	116
Preferences tab .....	117
Manage Preferences .....	117
Slots tab (SR only) .....	121
Manage Slots .....	122
Date and Time tab .....	123
Local Settings sub-tab .....	123
NTP Server sub-tab .....	125
NTP Authentication sub-tab .....	126
Toolkit tab .....	127
Reboot tool .....	127
Shutdown tool .....	128
Software Upgrade tool .....	128
Save Settings tool .....	130
Apply Settings tool .....	132
Restore to Factory Default Settings tool .....	133
System Certificate tool .....	134
System Configuration Checksum tool .....	137
Network Tools tool .....	138
API tool .....	140
File Manager tool .....	144
Diagnostic Data tool .....	148
Cloud Enrollment tool .....	149
Logging tab .....	150
Custom Fields tab .....	151
Dial-Up tab .....	152
Services sub-tab .....	152
Callback Users sub-tab .....	153
Scheduler tab .....	154
Manage Tasks .....	154
SMS tab (only with installed cellular module) .....	157
Settings sub-tab .....	157
Whitelist sub-tab .....	160
Remote File System tab .....	160
Manage Remote File System .....	161
I/O Ports tab (only with GPIO) .....	164
Configure I/O Port Settings .....	165
Network Section .....	166
Settings tab .....	166

- Manage Settings ..... 167
- Connections tab ..... 171
  - Manage Network Connections ..... 172
  - Create Interface Connections ..... 174
- Switch tab (NSR, GSR, BSR) ..... 197
  - Switch Interfaces sub-tab ..... 198
  - Backplane sub-tab ..... 201
  - VLAN sub-tab ..... 201
  - PoE sub-tab (NSR with PoE card, GSR) ..... 203
  - ACL sub-tab (NSR only) ..... 205
  - LAG sub-tab (NSR only) ..... 206
  - MSTP sub-tab (NSR only) ..... 208
  - Global sub-tab (BSR, GSR) ..... 210
  - Global sub-tab (NSR only) ..... 211
  - Port Mirroring sub-tab (NSR only) ..... 212
  - DHCP Snooping sub-tab (NSR only) ..... 214
- Static Routes tab ..... 215
  - Manage Static Routes ..... 215
- Hosts tab ..... 217
  - Manage Hosts ..... 217
- SNMP tab ..... 218
  - Manage SNMP ..... 218
- Wireless Modem tab ..... 220
  - Manage Wireless Modem ..... 220
- Flow Exporter tab ..... 222
  - Add a new Flow Export ..... 223
- 802.1x tab (Net SR only) ..... 224
  - Profiles sub-tab ..... 224
  - Credentials sub-tab ..... 227
- QoS tab ..... 229
  - Interfaces sub-tab ..... 230
  - Classes sub-tab ..... 232
  - Rules sub-tab ..... 234
- SD-WAN tab ..... 237
  - Application sub-tab ..... 237
  - Path Steering sub-tab ..... 238
  - Link Profile sub-tab ..... 240
  - Path Quality sub-tab ..... 241
  - Settings sub-tab ..... 243
- DHCP drop-down > DHCP Server tab ..... 244
  - Manage DHCP Server ..... 244
- DHCP drop-down > DHCP Relay tab ..... 250
  - Manage DHCP Relay ..... 250
- VPN drop-down > SSL VPN tab ..... 251
  - Client sub-tab ..... 252
  - Server sub-tab ..... 256
  - Server Status sub-tab ..... 259
- VPN drop-down > IPsec tab ..... 259
  - Overview ..... 259
  - IPsec Configuration Process ..... 262
  - Tunnel sub-tab ..... 263
  - IKE Profile sub-tab ..... 266
  - Global sub-tab ..... 269
- VPN drop-down > Wireguard tab ..... 270

- Manage Wireguard Configurations.....271
- Managed Devices Section.....277
  - General Information .....277
    - Supported Protocols.....277
    - Device Types.....277
  - Devices tab .....279
    - Device Types.....281
    - Device Procedures .....285
  - Configure Individual Device Settings .....297
    - Access sub-tab.....298
    - Management sub-tab .....307
    - Logging sub-tab.....309
    - Custom Fields sub-tab.....314
    - Commands sub-tab .....316
  - Views tab .....320
    - Tree sub-tab .....320
    - Image sub-tab .....322
  - Types tab .....326
    - Manage Types.....327
  - Auto Discovery tab.....328
    - Auto Discovery Configuration Process .....328
    - Auto Discovery Configurations .....329
    - Network Scan sub-tab .....345
    - VM Manager sub-tab .....348
    - Discovery Rules sub-tab.....350
    - Hostname Detection sub-tab .....353
    - Discovery Logs sub-tab .....357
    - Discover Now sub-tab .....357
  - Preferences tab.....358
    - Power Menu sub-tab .....358
    - Session Preferences sub-tab .....359
    - Views sub-tab .....359
- Cluster Section .....361
  - Peers tab.....362
  - Settings tab .....362
    - Enrollment sub-tab .....363
    - Automatic Enrollment Range sub-tab .....367
  - Management tab .....368
    - Software Upgrade .....368
- Security Section .....369
  - Local Accounts tab.....369
    - Manage Local Users .....370
  - Password Rules tab .....373
    - Manage Password Rules.....373
    - User Response to Expired Password.....374
  - Authorization tab .....374
    - User Group Configuration Process.....375
    - User Group :: Members sub-tab .....376
    - User Group: Profile sub-tab.....377
    - User Group: Remote Groups sub-tab.....378
    - User Group: Devices sub-tab .....378
    - User Group: Outlets sub-tab.....383
    - Configure SSH Key Authentication.....384
  - Authentication tab .....384

Servers sub-tab .....	385
2-Factor sub-tab .....	393
SSO sub-tab .....	398
Firewall tab .....	403
Manage Chains .....	404
NAT tab .....	410
Manage Chains .....	411
Manage Chain Settings .....	412
Services tab .....	417
General Services sub-tab .....	418
Intrusion Prevention sub-tab .....	425
GEO Fence tab .....	427
Manage GEO Fence .....	427
SED Pre-Boot Authenticator (PBA) .....	428
RFID Tag tab .....	429
Manage RFID Tag .....	429
Auditing Section .....	430
Settings tab .....	430
Data Logging Settings .....	431
Events tab .....	431
Event List sub-tab .....	432
Categories sub-tab .....	434
Destinations tab .....	437
File sub-tab .....	437
Syslog sub-tab .....	438
SNMP Trap sub-tab .....	439
Email sub-tab .....	441
Dashboard Section .....	442
Description .....	442
Navigation Tabs .....	442
Toolbar Description .....	443
Configuration Expressions of Data Points .....	445
Discover tab .....	446
Data Point Exploration .....	446
Visualize tab .....	447
Line Charts .....	447
Area Charts .....	453
Dashboard tab .....	455
Manage Dashboards .....	456
Timelion tab .....	458
Toolbar tabs .....	459
Management tab .....	461
Index Patterns sub-tab .....	462
Saved Objects sub-tab .....	462
Advanced Settings sub-tab .....	463
Applications Section .....	463
Docker tab .....	463
Virtualization .....	464
Docker Images .....	465
Virtual Machines tab .....	466
Storage Pools .....	466
Networks .....	471
Libvirt VM Tool .....	473

- WiFi Controller tab ..... 474
  - Install OpenWiFi ..... 474
  - Applications :: WiFi Controller :: Gateway ..... 475
  - Applications :: WiFi Controller :: Provisioning ..... 478
- Network Function Virtualization ..... 480
- Appendix A – General Information ..... 481
  - Technical Support ..... 481
    - Support Ticket ..... 482
    - Updates and Patches ..... 482
  - Manage Virtual Machines ..... 482
  - Virtual Serial Port (vSPC) on VM Servers ..... 483
  - Serial Port Pinout ..... 485
  - Safety ..... 486
  - Quick Install Guide ..... 486
  - RoHS ..... 487
  - Data Persistence ..... 487
    - Nodegrid Device Memory ..... 487
  - Remove Data from Nonvolatile Memory ..... 487
    - Soft Removal of User Data from Nonvolatile Memory ..... 487
    - Hard Removal - Secure Erase ..... 488
  - Mount Remote Shares for Virtual Media ..... 490
  - Monitoring Templates ..... 490
    - Customize a Monitoring Template ..... 490
    - SNMP Template ..... 491
    - IPMI Discovery Template ..... 492
  - Supported Nodegrid Devices ..... 493
    - USB Passthrough ..... 493
    - USB Power ..... 493
    - USB Type ..... 494
    - KVM Dongle ..... 494
    - Bluetooth ..... 494
    - 5G Support ..... 495
  - PXE Boot ..... 497
  - VRRP (Virtual Router Redundancy Protocol) ..... 499
    - Example Configuration ..... 499
- Appendix B – UEFI Implementation ..... 502
  - UEFI Upgrade/Downgrade Concerns ..... 502
    - Enable Secure Boot (optional) ..... 503
  - Downgrade to Legacy ..... 503
  - Self-Encrypting Drive ..... 504
    - Minimum BIOS Versions ..... 504
    - Device Conditions ..... 505
    - Security Adjustments to System ..... 505
  - Secure Boot ..... 505
    - Requirements ..... 505
  - Intrusion Prevention ..... 505



# About the Nodegrid v5.6 User Guide

Document updated: September 10, 2022.

All manuals ([PDF and HTML format](#)) are available here.

If any features/functions cannot be viewed, user does not have necessary privileges.

This document provides user information and details on the Nodegrid Platform and the supporting units:

- Nodegrid Serial Console Series
- Nodegrid Net Services Router
- Nodegrid Gate SR
- Nodegrid Bold SR
- Nodegrid Link SR
- Nodegrid Hive SR
- Nodegrid Mini SR

## Notifications

### USA

**WARNING:** Changes or modifications to this unit not expressly approved by the party responsible for compliance could void the user's authority to operate the equipment.

This equipment has been tested and found to comply with the limits for a Class A digital device, pursuant to Part 15 of the FCC Rules. These limits are designed to provide reasonable protection against harmful interference when the equipment is operated in a commercial environment. This equipment generates, uses and can radiate radio frequency energy and, if not installed and used in accordance with the instruction manual, may cause harmful interference to radio communications. Operation of this equipment in a residential area is likely to cause harmful interference, in which case the user will be required to correct the interference at his/her own expense.

### Canada

This Class A digital apparatus complies with Canadian ICES-003.

Cet appareil numérique de la classe A est conforme à la norme NMB-003 du Canada.

### European Union

This is a class A product. In a domestic environment, this product may cause radio interference in which case, the user may be required to take adequate measures.

**IMPORTANT:** All other marks are the property of their respective owners. This document may contain confidential and/or proprietary information of ZPE Systems, Inc., and its receipt or possession does not convey any right to reproduce, disclose its contents, or to manufacture or sell anything that it may describe. Reproduction, disclosure, or use without specific authorization from ZPE Systems, Inc. is strictly prohibited.

## Credits

ZPE Systems, the ZPE logo, Nodegrid Manager, Nodegrid, FireTrail, Cloud Clustering, DeviceURL and NodeIQ are either registered trademarks or trademarks of ZPE Systems. Other company and product names may be trademarks of their respective owners.

©2022 ZPE Systems, Inc.

### Contact us

Sales: [sales@zpesystems.com](mailto:sales@zpesystems.com)

Support: [support@zpesystems.com](mailto:support@zpesystems.com)

ZPE Systems, Inc.  
3793 Spinnaker Court  
Fremont, CA 94538 USA

[www.zpesystems.com](http://www.zpesystems.com)

# Product Overview

## Nodegrid Serial Console

The Nodegrid Serial Console product line consolidates and manages attached devices via a Serial Port Connection including servers, network routers and switches, storage, PDUs, UPSs, and any other device with a serial port.

### *Nodegrid Serial Console - S Series*

The Nodegrid Serial Console (S Series) is designed to fit modern and legacy mixed environment. With auto-sensing ports, the S Series Console Servers can be used within any environment with straight-through cables or legacy adapters.

Features include:

- Auto-Switching (Cisco or Legacy Pin-out)
- 16/32/48/96 Serial Ports
- Additional USB ports

- Factory upgradeable CPU and RAM
- 1U 19" Rack Standard Unit
- Single AC, Dual AC, and Dual DC
- Fan options

### Nodegrid Serial Console - S Series Hardware Specifications

Item	Description
CPU	Intel x86_64 dual core CPU
Memory & Storage	4 GB of DDR3 DRAM 32 GB mSATA SSD
Interfaces	16, 32, 48, 96 RS-232 serial ports on RJ45 @ 230,400 bps max/port 2 Gb (10/100/1000BT) Ethernet interfaces on RJ45 or (optional) 2 SFP+ 1/2.5/10GB compatible 1 RS-232 serial console port on RJ45 1 USB 3.0 Host and 2 USB 2.0 Hosts on Type A connector 1 HDMI output port
Power	40V-63 VDC dual power input (redundant) Power consumption 45 W typical Single or Dual AC: 100-240 VAC, 50/60 Hz
Physical	Front-Rear mounting brackets Size (L x W x H): 443 x 312 x 43 mm (17.4 x 12.3 x 1.7 in), 1U Weight: 4.9 kg (10.8 lb), depending on options Shipping weight: 7.65 kg (17 lb) Shipping (L x W x H): 600 x 440 x 210 mm (23.6 x 17.3 x 8.3 in) F: front-to-back or back-to-front fans (Swappable) B: no fans
Environmental	Operation: 0 to 50° C (32 to 122° F), 5-95% RH, non-cond. Storage: -20 to 67° C (-4 to 153° F), 5-95% RH, non-cond.

### Nodegrid Serial Console - S Series Front Interfaces (F: with fan)



### Nodegrid Serial Console - S Series Front Interfaces (B: without fan)



Port	Description
HDMI	HDMI Interface
USB	USB 2.0 Port
PWR	Power LED Green:·Solid - normal,· Off - power is off
SYS	System LED Green:· Blinking – normal,· Fast Blink - RST button Acknowledgment,· Off or Solid - no activity
RST	Reset button: <3s system reset,>10s configuration factory reset and system reset
FAN	Fan options: F (with fan), B (without fan)
USB	1 USB 2.0 Port, 12 USB 1.1 Ports

### Nodegrid Serial Console - S Series Rear Interfaces



Port	Description
Power	Single or Dual Power Sockets
Serial	Serial Interfaces: Right/Orange DCD/DTR – On (port open and/or cable connected), Off (not ready) Left/Green RX/T- Blinking (data activity), Off (no activity)

Port	Description
ETH0/SFP0	<p>Network Interface</p> <p>Copper:-Left/Green: Blinking (data activity), Solid (ready), Off (no link/cable disconnected Ethernet fault)-Right/Green (1000Base-T link speed), Right/Orange (100BaseT link speed). Right/Off (no link/cable disconnected/Ethernet fault)</p> <p>SFP 1Gb/10Gb:-Left/Green – Blinking (data activity), Solid (ready), Off (no link/cable disconnected/Ethernet fault)</p> <p>Right/Green - 10Gb link speed:-Right/Orange (1Gb link speed),Right/Off (no link/cable disconnected/Ethernet fault)</p>
ETH1/SFP1	<p>Network Interface</p> <p>Copper:-Left/Green: Blinking (data activity), Solid (ready), Off (no link/cable disconnected/Ethernet fault)</p> <p>Right/Green (1000Base-T link speed),-Right/Orange (100BaseT link speed),-Right/Off (no link/cable disconnected/Ethernet fault)</p> <p>SFP 1Gb/10Gb:-Left/Green: Blinking (data activity), Solid (ready), Off (no link/cable disconnected/Ethernet fault)</p> <p>Right/Green (10Gb link speed),-Right/Orange (1Gb link speed),-Right/Off (no link/cable disconnected/Ethernet fault)</p>
Console	<p>Console MGMT Interface</p> <p>Right/Orange (LED Power Failure), Blinking:(Power supply failure/off – for dual power supply models), Off (normal)</p> <p>Left/Green LED System Activity: Blinking (normal), Off or Solid (no activity)</p>
USB	1 USB 3.0

## Nodegrid Serial Console - R Series

The Nodegrid Serial Console (R Series) fits into major hardware environments like Cisco, Arista, Dell, Palo Alto Networks, and Juniper. The R Series Serial Consoles are perfect for retrofits and to upgrade rack standards of existing builds.

Features include:

- For Cisco Pin-out Devices
- 16/32/48/96 Serial Ports
- 1U 19" Rack Standard Unit
- Single AC, Dual AC, and Dual DC

### Nodegrid Serial Console - R Series Hardware Specifications

Item	Description
CPU	Intel Atom x86_64 dual core @ 1.75 GHz CPU
Memory & Storage	4 GB of DDR3 DRAM 32 GB mSATA SSD

Item	Description
Interfaces	16, 32, 48, 96 RS-232 serial ports on RJ45 @ 230,400 bps max/port. 2 Gigabit (10/100/1000BT) Ethernet interfaces on RJ45 or optionally 2 SFP+ 1/2.5/10GB compatible 1 RS-232 serial console port on RJ45 1 USB 3.0 Host and 2 USB 2.0 Hosts on Type A connector 1 HDMI output port
Power	40V-63 VDC dual power input (redundant) Power consumption 45 W typical Single or Dual AC: 100-240 VAC, 50/60 Hz
Physical	Front-Rear mounting brackets Size (L x W x H): 443 x 312 x 43 mm (17.4 x 12.3 x 1.7 in), 1U Weight: 4.9 kg (10.8 lb), depending on options Shipping weight: 9.5 kg (20.9 lb) Shipping (L x W x H): 600 x 440 x 210 mm (23.6 x 17.3 x 8.3 in)
Environmental	Operation: 0 to 50° C (32 to 122° F), 5-95% RH, non-cond. Storage: -20 to 67° C (-4 to 153° F), 5-95% RH, non-cond.

### Nodegrid Serial Console - R Series Front Interfaces



Port	Description
HDMI	HDMI Interface
USB	2 USB 2.0 Port
PWR	Power LED Green:· Solid - normal,· Off - power is off
SYS	System LED Green:· Blinking – normal, Fast Blink - RST button Acknowledgment, Off or Solid - no activity
RST	Reset button:<3s system reset,>10s configuration factory reset and system reset

### Nodegrid Serial Console - R Series Rear Interfaces



Port	Description
Power	Single or Dual Power Sockets
Serial	Serial Interfaces: Right/Orange DCD/DTR – On (port open and/or cable connected), Off (not ready) Left/Green RX/T- Blinking (data activity), Off (no activity)
ETH0/SFP0	Network Interface Copper:·Left/Green – Blinking (data activity), Solid (ready), Off (no link/cable disconnected/Ethernet fault) Right/Green (1000Base-T link speed), Right/Orange (100BaseT link speed), Right/Off (no link/cable disconnected/Ethernet fault) SFP 1Gb/10Gb:·Left/Green – Blinking (data activity), Solid (ready), Off (no link/cable disconnected/Ethernet fault) Right/Green (10Gb link speed),·Right/Orange (1Gb link speed),·Right/Off (no link/cable disconnected/Ethernet fault)
ETH1/SFP1	Network Interface Copper:·Left/Green – Blinking (data activity), Solid (ready), Off:(no link/cable disconnected/Ethernet fault) Right/Green (1000Base-T link speed), Right/Orange (100BaseT link speed), Right/Off (no link/cable disconnected/Ethernet fault) SFP 1Gb/10Gb:·Left/Green – Blinking (data activity), Solid (ready), Off (no link/cable disconnected/Ethernet fault) Right/Green (10Gb link speed), Right/Orange (1Gb link speed), Right/Off (no link/cable disconnected/Ethernet fault)
Console	Console MGMT Interface Right/Orange (LED Power Failure), Blinking (Power supply failure/off - for dual power supply models), Off (normal) Left/Green (LED System Activity) – Blinking (normal), Off or Solid (no activity)
USB	USB 3.0

### **Nodegrid Serial Console - T Series**

The Nodegrid Serial Console (T Series) fits into environments that still utilize legacy devices and can be a direct replacement for any legacy console server.

Features include:

- For Legacy Devices
- 16/32/48/96 Serial Ports
- 1U 19" Standard Unit
- Single AC, Dual AC, and Dual DC

#### **Nodegrid Serial Console - T Series Hardware Specifications**

Item	Description
CPU	Intel Atom x86_64 dual core @ 1.75 GHz CPU

Item	Description
Memory & Storage	4 GB of DDR3 DRAM 32 GB mSATA SSD
Interfaces	2 Gigabit (10/100/1000BT) Ethernet interfaces on RJ45 or 2 SFP+ Fiber interfaces compatible with 1Gb 2.5Gb / 10Gb modules 16, 32, 48, 96 RS-232 serial ports on RJ45 @ 230,400 bps max/port 1 RS-232 serial console port on RJ45 1 USB 3.0 Host 2 USB 2.0 Hosts on Type A connector HDMI
Power	Single/Dual AC 100-240 VAC, 50/60 Hz Dual DC: 40-63 VDC Power consumption 45 W (on 96 ports)
Physical	Front-Rear mounting brackets Size (L x W x H): 443 x 312 x 43 mm (17.4 x 12.3 x 1.7 in), 1U Weight: 4.9 kg (10.8 lb), depending on options Shipping weight: 9.5 kg (20.9 lb) Shipping (L x W x H): 600 x 440 x 210 mm (23.6 x 17.3 x 8.3 in)
Environmental	Operation: 0 to 50° C (32 to 122° F), 5-95% RH, non-cond. Storage: -20 to 67° C (-4 to 153° F), 5-95% RH, non-cond.

### Nodegrid Serial Console - T Series Front Interfaces



Port	Description
HDMI	HDMI Interface
USB	2 USB 2.0 Port
PWR	Power LED Green:· Solid - normal,· Off - power is off
SYS	System LED Green:· Blinking – normal, Fast Blink - RST button Acknowledgment, Off or Solid - no activity
RST	Reset button:<3s system reset,>10s configuration factory reset and system reset
HDMI	HDMI Interface



### Nodegrid Serial Console - T Series Rear Interfaces



Port	Description
Power	Single or Dual Power Sockets
Serial	Serial Interfaces: Right/Orange DCD/DTR – On (port open and/or cable connected), Off (not ready) Left/Green RX/T- Blinking (data activity), Off (no activity)
ETH0/SFP0	Network Interface Copper: Left/Green – Blinking (data activity), Solid (ready), Off (no link/cable disconnected/Ethernet fault) Right/Green (1000Base-T link speed), Right/Orange (100BaseT link speed), Right/Off (no link/cable disconnected/Ethernet fault) SFP 1Gb/10Gb: Left/Green – Blinking (data activity), Solid (ready), Off (no link/cable disconnected/Ethernet fault) Right/Green (10Gb link speed), Right/Orange (1Gb link speed), Right/Off (no link/cable disconnected/Ethernet fault)
ETH1/SFP1	Network Interface Copper: Left/Green – Blinking (data activity), Solid (ready), Off:(no link/cable disconnected/Ethernet fault) Right/Green (1000Base-T link speed), Right/Orange (100BaseT link speed), Right/Off (no link/cable disconnected/Ethernet fault) SFP 1Gb/10Gb: Left/Green – Blinking (data activity), Solid (ready), Off (no link/cable disconnected/Ethernet fault) Right/Green (10Gb link speed), Right/Orange (1Gb link speed), Right/Off (no link/cable disconnected/Ethernet fault)
Console	Console MGMT Interface Right/Orange (LED Power Failure), Blinking (Power supply failure/off - for dual power supply models), Off (normal) Left/Green (LED System Activity) – Blinking (normal), Off or Solid (no activity)
USB	USB 3.0

## Nodegrid Net Services Router Family

The Nodegrid Net Services Router (NSR) is a platform appliance designed for software-defined networking (SDN), out of band (OOB) management, DevOps, cellular failover, docker, SD-WAN, remote/branch offices, retail locations, and network function virtualization (NFV) capabilities.

## Nodegrid Net Services Router

The Nodegrid Net Services Router is a modular, open platform appliance designed for software-defined networking (SDN), out of band (OOB) management, DevOps, cellular failover, docker, SD-WAN, remote/branch offices, retail locations, and network function virtualization (NFV) capabilities.

Features include:

- Open Framework, Modular Services Router
- Pluggable Expansion Modules - 5 slots available
- Modules for GbE, Serial, SFP+ 10GbE, PoE+, USB, M.2/SATA + Antenna, Storage, Extra Compute
- 1U 19" Standard Unit
- Separation of Control Plane and Data Plane

### Nodegrid Net Services Router Hardware Specifications

Item	Description
CPU	Intel Multi-core x86_64 CPU
Memory & Storage	8 GB of DDR4 DRAM (Upgradeable) 32 GB FLASH (mSATA SSD) (Upgradeable) Self-Encrypted Drive (SED)
Interfaces	2 SFP+ Ethernet 2 Gigabit Ethernet 1 RS-232 serial console port on RJ45 1 USB 3.0 1 USB 2.0 1 HDMI
Power	Dual AC 100-240 VAC, 50/60 Hz or Dual DC 36-75 VDC Power Consumption 90W-150W typical
Physical	Front-Rear mounting brackets Size (L x W x H): 438 x 332 x 43mm (17.2 x 13.1 x 1.7 in), 1U Weight: 4.9 kg (10.8 lb), depending on options Air Exhaust or Air Intake Fans (Swappable)
Environmental	Operation: 0 to 45° C (32 to 113° F), 5-95% RH, non-cond. Storage: -20 to 67° C (-4 to 153° F), 10-90% RH, non-cond.

### Nodegrid Net Services Router Front Interfaces



Port	Description
Slot 1	Slot for Module
Slot 2	Slot for Module
Slot 3	Slot for Module
SFP+ 0	Network Interface- Left/Green – Blinking (data activity), Solid (ready), Off (no link/cable disconnected/Ethernet fault) Right/Green (10Gb link speed), Right/Orange (1Gb link speed), Right/Off (no link/cable disconnected/Ethernet fault)
SFP+ 1	Network Interface- Left/Green – Blinking (data activity), Solid (ready), Off (no link/cable disconnected/Ethernet fault) Right/Green (10Gb link speed), Right/Orange (1Gb link speed), Right/Off (no link/cable disconnected/Ethernet fault)
ETH0	Network Interface- Left/Green – Blinking (data activity), Solid (ready), Off (no link/cable disconnected/Ethernet fault) Right/Green (1000Base-T link speed), Right/Orange (100BaseT link speed), Right/Off (no link/cable disconnected/Ethernet fault)
ETH1	Network Interface- Left/Green – Blinking (data activity), Solid (ready), Off (no link/cable disconnected/Ethernet fault) Right/Green (1000Base-T link speed), Right/Orange (100BaseT link speed), Right/Off (no link/cable disconnected/Ethernet fault)
Console	Console MGMT Interface Right/Orange (LED Power Failure), Blinking (Power supply failure/off for dual power supply models), Off (normal) Left/Green (LED System Activity), Blinking (normal), Off or Solid (no activity)
USB	USB 3.0
RST	Reset button: <3s (system reset) >10s (configuration factory reset and system reset)

### Nodegrid Net Services Router Rear Interfaces













Port	Description
Slot 4	Slot for Module (depending on the Model)
Slot 5	Slot for Module (depending on the Model)
USB	2 USB 2.0 Port
HDMI	HDMI Interface
PWR	Power LED Green:· Solid - normal,· Off - power is off
SYS	System LED Green:· Blinking – normal, Fast Blink - RST button Acknowledgment, Off or Solid - no activity
FAN	Fans
Power Socket	Dual Power Sockets
Power	Single or Dual Power Sockets

### Nodegrid Net Services Router Expansion Modules

The Nodegrid Net Services Router has up to five slots for modules that provide extreme flexibility and expanded functionality.

#### Nodegrid Net Services Router Expansion Modules

Module	Image	Specification
16-Port 1GbE		1000BASE-T Cat5e or better
16-Port SFP 1GbE		Supports all SFP Modules

Module	Image	Specification
8-Port SFP+ 10GbE		Supports all SFP+ Modules
8-Port PoE+		25.5W mapower per port Total ma150W PoE+ available Configurable power budget
16-Port Serial		RJ45 Serial Rolled port ma230,400 bps
16-Port USB		USB 2.0 interfaces Type A
M.2 Cellular + Antenna		For up to 24G/LTE modems
M.2 SATA		For up to 2mSATA storage modules
Storage		For 2.5" SATA (HDD/SDD) storage
Compute		Compute module (server on a card), provides independent compute capabilities.

### Expansion Module Compatibility Chart

Expansion card	Slot 1	Slot 2	Slot 3	Slot 4	Slot 5
16-Port GbE Ethernet	✓	✓	✓	Secure Isolated Mode **	Secure Isolated Mode **
16-Port SFP	✓	✓	✓	Secure Isolated Mode **	Secure Isolated Mode **
16-Port Serial	✓	✓	✓	✓	✓
16-Port USB	✓	✓	✓	✓	✓
M.2 Cellular / WiFi	✓	✓	✓	✓	✓

Expansion card	Slot 1	Slot 2	Slot 3	Slot 4	Slot 5
8-Port SFP+	✓	✓	✓	Secure Isolated Mode **	Secure Isolated Mode **
8-Port POE+	✓	✓	✓	—	—
Compute	✓	✓	✓	Secure Isolated Mode **	Secure Isolated Mode **
Storage *	—	—	—	✓	✓
M.2 SATA *	—	—	—	✓	✓

**NOTES:**

(\*) The Nodegrid Net Services Router supports a maximum of 2 SATA drives, which can be divided into 2 Storage cards or in one M.2 SATA card.

(\*\*) The Secure Isolated Mode allows for the management of the cards as if they would be located in a normal Slot, but the network traffic is isolated from any other slot.

**Configure Extra Storage Devices on NSR**

**IMPORTANT:** When additional storage is added, special steps are required to allow the system to see more than one disk (i.e., use both storage and an LTE/M2.SATA module).

If using Storage and LTE/M2.SATA:

LTE/M2.SATA must be installed in slot 4.

Storage module must be installed in slot 5.

M2.SATA must be installed in Channel A.

Modem must be installed in Channel B.

1. In the WebUI, go to *System :: Slots :: 5*.

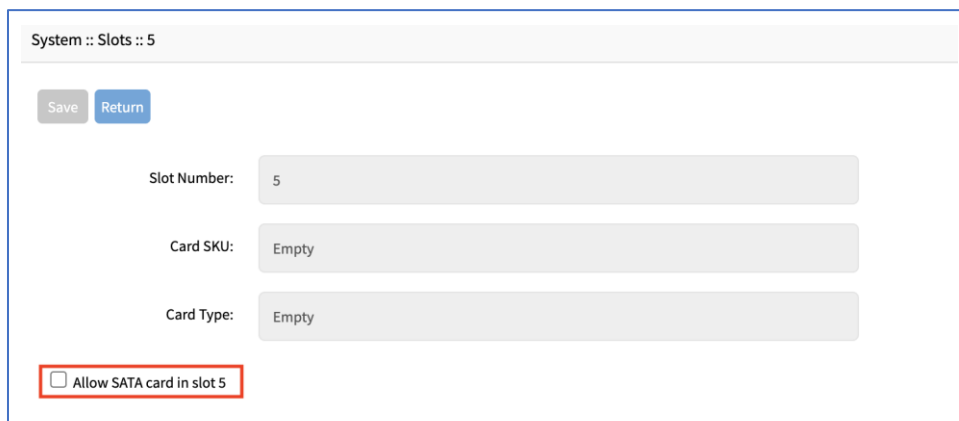

The screenshot shows the configuration page for Slot 5. At the top, there are 'Save' and 'Return' buttons. Below them are three input fields: 'Slot Number' with the value '5', 'Card SKU' with the value 'Empty', and 'Card Type' with the value 'Empty'. At the bottom of the form, there is a checkbox labeled 'Allow SATA card in slot 5', which is currently unchecked and highlighted with a red rectangular box.

2. Select **Allow SATA card in slot 5** checkbox.
3. Click **Save**.

## Nodegrid Gate SR

The Nodegrid Gate SR brings agility to any network. Perfect for both data center and branch, Nodegrid Gate SR packs tremendous power in a small form factor – to provide a truly robust and dynamic, secure infrastructure management solution. Configuration and management of the Nodegrid Gate SR is easily done on the ZPE Cloud application.



Features include:

- Secure, fast, and consistent deployments across all your branches with ZPE Cloud
- Software Defined Networking, Network Function Virtualization, Guest OS, Kubernetes, and Docker capabilities
- Minimizes MTTR, downtime and expenses with secure, centralized remote device access & control
- Increases site reliability with open industry standard hardware and easy-to-use software
- Zero Touch Provisioning (ZTP) for fast and easy setup in remote locations
- Integrates with ZPE Cloud and ZPE Systems Nodegrid Manager for a vendor-neutral, unified management solution
- Direct Linux shell, HTML5 cross-device web access, and command line interface
- Modern 64-bit Linux Kernel for fast security patching and widespread software availability
- Kubernetes and Docker-optimized for quick, flexible script and application integration
- Extended Automation based on actionable real-time data
- Failover to 4G/LTE modem

- Gateway and multi-routing table capability
- VPN and IPsec
- DHCP server – extra IPs for your remote site or replace your current router altogether
- Firewall – built-in and turns on with a check box
- Secure – selectable encrypted cryptographic protocols and cipher suite levels, and a configuration checksum™
- Power control and monitoring – get alerts on suboptimal IT device health before malfunctions occur and solve problems automatically
- Orchestration - Puppet, Chef, Ansible, RESTful and ZPE Cloud
- WiFi hotspot ready via internal card or add your AP (Access Point) via a PoE+ port
- High density and flexible interfaces for greater connectivity

### Nodegrid Gate SR Hardware Specifications

Item	Description
CPU	Intel Multi-core x86_64 CPU
Memory & Storage	8-32GB DDR4 DRAM 32GB Hardware encrypted SSD
Interfaces	8 RJ45 Serial ports 2 SFP+ (10G) 1 Gigabit (10/100/1000BT) Ethernet interfaces on RJ45 4 Gigabit (10/100/1000BT) Ethernet interfaces on RJ45 with Built-in Switch 4 PoE+ Gigabit (10/100/1000BT) Ethernet interfaces on RJ45 with Built-in Switch 2 GPIO (Digital I/O TTL level 5.5V max @ 64mA) 1 Digital Out Port (Signal MOSFET Digital Output 2.5V to 60V @ 500mA max) 1 Relay Port (NC relay contact max 24V @ 1A) 2 USB 3.0 Host on Type A 2 USB 2.0 Hosts on Type A 1 Wi-Fi (optional) 2 Cellular Slots with Dual SIM (optional) 1 HDMI port
Power	36V-75 VDC dual power input (redundant) Power consumption 45 W typical AC Power adapter (add-on), 100-240V~, 1.2A, 50-60Hz (operating temperature: -25C – 60C)
Physical	Front-Rear mounting brackets Size (L W H): 241.3 x 260.4 x 44.5 mm (9.5 x 10.25 x 1.75 in) Weight: .9 kg (2 lb) Shipping weight: 3.6 kg (8.0 lb) Shipping (L W H): 349.2 x 374.7 x 177.8 mm (13.75 x 14.75 x 7 in)
Environmental	Operation: 0 to 60° C (32 to 140° F), 5-95% RH, non-cond. Storage: -20 to 67° C (-4 to 153° F), 5-95% RH, non-cond.



### Nodegrid Gate SR Front Interfaces



Interface	Description
DIO0	Digital I/O TTL level 5.5V ma@ 64mA
DIO1	Digital I/O TTL level 5.5V ma@ 64mA
OUT0	Signal MOSFET Digital Output 2.5V to 60V @ 500mA max
Relay Output	NC relay contact ma24V @ 1A
Console	Console MGMT Interface
USB	2 USB 2.0
HDMI	Monitor Interface
Channel A	Signal Strength indicator for Channel A
Channel B	Signal Strength indicator for Channel B
PWR	Power LED Green:· Solid - normal· Off - power is off
SYS	System LED Green:· Blinking – normal, Fast Blink - RST button Acknowledgment, Off or Solid - no activity
RST	Reset button:<3s system reset>10s reset to factory default and system reset
Power Switch	Power on/off Switch

### Nodegrid Gate SR Rear Interfaces



Port	Description
PWR	Power LED Green:- Solid – normal, Off - power is off
V2- / GND / V2+	Power Connector for External Power Supply: 36V - 75VDC dual power input (redundant)
V1- / GND / V1+	Power Connector for External Power Supply: 36V - 75VDC dual power input (redundant)
PoE+	4 PoE+ Network Interface numbered 1 to 4- Left/Green – Blinking (data activity), Solid (ready), Off (no link/cable disconnected/Ethernet fault) Right/Green (1000Base-T link speed),-Right/Orange (100BaseT link speed),-Right/Off (no link/cable disconnected/Ethernet fault)
NET	4 Network Interface numbered 5 to 8 Left/Green – Blinking (data activity), Solid (ready), Off (no link/cable disconnected/Ethernet fault) Right/Green (1000Base-T link speed),-Right/Orange (100BaseT link speed),-Right/Off (no link/cable disconnected/Ethernet fault)
SFP+ 0	SFP+ Network Interface 0 Left/Yellow – Solid (Link UP), Off (no link/cable disconnected)- Right/Green – Solid (Link UP), Blinking (Activity), Off (no link/cable disconnected)
SFP+ 1	SFP+ Network Interface 1- Left/Yellow – Solid (Link UP), Off (no link/cable disconnected)- Right/Green – Solid (Link UP), Blinking (Activity), Off (no link/cable disconnected)
ETH0	Network Interface- Left/Yellow – Solid (Link UP), Blinking (data activity), Off (no link/cable disconnected/Ethernet fault)- Right/Green – Solid (1000Base-T link speed), Off (100/10BaseT link speed or off)
USB	2 USB 3.0 Port
Serial	Serial Interfaces 1-8- Right/Orange DCD/DTR – On (port open and/or cable connected), Off (not ready) Left/Green RX/T- Blinking (data activity), Off (no activity)

## Nodegrid Hive SR

The Nodegrid Hive SR is used for SD-WAN and SD-Branch applications.



**NOTE;** Hive SR default system profile is Gateway Profile.

Features include:

- Three M.2 slots for flexible combinations of up to Wifi 6, 5G and NVMe drives
- Four SIM card slots for up to two cellular modems
- Four RJ-45 Network Ports (2.5G)
- Two SFP+
- Two 1GbE Combo (RJ45/SFP)
- +12V DC power
- Fan-cooled
- Rack or wall mountable
- Five antenna slots.
- Zero Touch Provisioning (ZTP) for fast and easy setup in remote locations

- Integrates with ZPE Cloud and ZPE Systems Nodegrid Manager for a vendor-neutral, unified management solution

### Nodegrid Hive SR Hardware Specifications

Item	Description
CPU	Intel Atom C3558 - 4 cores
Memory & Storage	DDR4 16 GB, bus 64-bit, with ECC 16GB eMMC 128 GB NVMe SSD
Interfaces	4 RJ-45 Network Ports (2.5G) 2 SFP+ 2 1GbE Combo (RJ45/SFP) Console: Cisco RJ45 and micro-USB 2 USB 3.0 Host on Type A 4 SIM card slots Expansion Slot-0: M.2 Key-M (x2 PCIe Gen3), 128GB NVMe Channel-A (expansion slot-2): M.2 Key-B (x1 PCIe Gen3, USB3/2) optional cards: 5G cellular card or EM7565 Channel-B (expansion slot-1): M.2 Key-B (x1 PCIe Gen3, USB3/2) optional cards: Enli Wi-Fi 6 card, Wi-Fi 5 card, NVMe card or EM7565 second card.
Power	+12V DC Locking Barrel Jack External 60W PSU Power consumption 20W max (board only), 40W (includes max peripheral power)
Physical	Fan cooled. Rackmount accessory kit: Rackmount bracket, USB patch cables Wall-mount accessory kit: Unit mounting brackets, PSU mounting bracket – with hardware Size (L W H): 200 x 256 x 44 mm (7.87.x-10.07-x.1.73 in) Weight: .9 kg (2 lb) Shipping weight: 3.6 kg (8.0 lb) Shipping (L W H): 349.2 x 374.7 1x 77.8 mm (13.75 x 14.75 x 7 in)
Environmental	Operation: 0 to 60° C (32 to 140° F), 5-95% RH, non-cond. Storage: -20 to 67° C (-4 to 153° F), 5-95% RH, non-cond.

### Nodegrid Hive SR Side Interfaces



Interface	Description
Left LED (PWR/Status)	AMBER (has power, standby). During BOOT: BLUE (unit starts boot) Operating: GREEN (system booted), blinking RED (alarm), solid RED (reset button pressed more than 10sec)
Middle LED	During BOOT: OFF Operating: M.2 - Channel A signal strength – OFF (no signal), solid RED (poor), solid AMBER (fair), solid BLUE (good), solid GREEN (excellent)
Right LED	During BOOT: OFF Operating: M.2 - Channel B signal strength – OFF (no signal), solid RED (poor), solid AMBER (fair), solid BLUE (good), solid GREEN (excellent)
(optional) SIM CARDS	SIM Slot-A1 SIM Slot-A2 SIM Slot-B1 SIM Slot-B2
USB	2 USB 3.0
Protruding Button	2-7s (graceful OS shutdown and set status bit) <4s (no action) 4-7s (graceful OS shutdown) >7s (immediate CPU shutdown)
Recessed Button	<10s (hardware reset) >10s (Factory default unit and reboot)

### Nodegrid Hive SR Rear Interfaces



Port	Description
MicroUSB	Console Port
Console Port	Cisco RJ-45 Left LED (not used) Right LED: Green Solid (RJ-45 cable connected); Off (microUSB)

Port	Description
WAN0 (1G)	CAT 5e or CAT 6 cable. Left LED (speed) Solid Amber (1G); Solid Green (100Mb); Off (10Mb). Right LED (data traffic): Solid Green (Link Up); Blinking Green (data traffic).
WAN1 (1G)	CAT 5e or CAT 6 cable Left LED (speed) Solid Amber (1G); Solid Green (100Mb); Off (10Mb). Right LED (data traffic): Solid Green (Link Up); Blinking Green (data traffic).
SFP0 (10G)	SFP+ Network Interface 0 Left LED: Solid Green (link ready), Off (no link). Right LED (data traffic): Solid Green (Link Up); Blinking Green (data traffic).
SFP1 (10G)	SFP+ Network Interface 1 Left LED: Solid Green (link ready), Off (no link). Right LED (data traffic): Solid Green (Link Up); Blinking Green (data traffic).
LAN[0-3]	Network Ports Left LED (speed) Solid Green(2.5G); Solid Amber (1G); Off (10/100M). Right LED (data traffic): Solid Green (Link Up); Blinking Green (data traffic).
Antenna Connection	(optional) 5G/LTE
Antenna Connection	(optional) WiFi Antenna
DC Power Adaptor	12VDC for External Power Supply

## **Nodegrid Bold SR**

The Nodegrid Bold SR is an open platform appliance designed for secure access and control over remote and IoT devices at the EDGE of your network. The Bold SR supports cellular failover, Network Function Virtualization (NFV), and Software Defined Networking with a focus on SD-WAN.



Features include:

- 1U high, compact size, high processing power
- Ideal for Software Defined Networking
- Network Function Virtualization
- Cellular failover
- WiFi hotspot & client
- Multiple Interfaces

### Nodegrid Bold SR Hardware Specifications

Item	Description
CPU	Intel Multi-core x86_64 CPU
Memory & Storage	4 GB of DDR3 DRAM 32 GB SATADOM SSD (Upgradeable)
Interfaces	8 RJ45 Serial ports 1 Gigabit (10/100/1000BT) Ethernet interfaces on RJ45 4 Gigabit (10/100/1000BT) Ethernet interfaces on RJ45 with Built-in Switch 2 USB 3.0 Host on Type A 2 USB 2.0 Hosts on Type A 1 Wi-Fi and Bluetooth Slot (optional) 2 Cellular CAT-12 Slots with Dual SIM (optional) 1 VGA port

Item	Description
Power	12VDC via external 100-240 VAC, 50/60 Hz adapter Power consumption 25 W typical
Physical	Front-Rear mounting brackets Size (L x W x H): 142 x 201 x 44 mm (5.5 x 7.9 x 1.73 in) Weight: 1.2 kg (2.6 lb) Shipping weight: 2.3 kg (5.0 lb) Shipping (L x W x H): 313 x 313 x 140 mm (12.3 x 12.3 x 5.5 in)

### Nodegrid Bold SR Front Interfaces



Port	Description
Channel A	Signal Strength indicator for Channel A
Channel B	Signal Strength indicator for Channel B
Console	Console MGMT Interface
PWR	Power LED Green:· Solid - normal,· Off - power is off
SYS	System LED Green:· Blinking - normal· Fast Blink - RST button Acknowledgment· Off or Solid - no activity
RST	Reset button:<3s system reset,>10s configuration factory reset and system reset
Power Switch	Power on/off Switch



### Nodegrid Bold SR Rear View



Port	Description
PWR IN	Power Socket for external Power Supply
Monitor	VGA Interface
ETH0	Network Interface Left/Green – Blinking (data activity), Solid (ready), Off (no link/cable disconnected/Ethernet fault) Right/Green (1000Base-T link speed), Right/Orange (100BaseT link speed), Right/Off (no link/cable disconnected/Ethernet fault)
USB	2 USB 2.0 Port 2 USB 3.0 Port
ETH1	Network Interface(NET) Left/Green – Blinking (data activity), Solid (ready), Off (no link/cable disconnected/Ethernet fault) Right/Green (1000Base-T link speed), Right/Orange (100BaseT link speed), Right/Off (no link/cable disconnected/Ethernet fault)
ETH2	Network Interface(NET) Left/Green – Blinking (data activity), Solid (ready), Off (no link/cable disconnected/Ethernet fault) Right/Green (1000Base-T link speed), Right/Orange (100BaseT link speed), Right/Off (no link/cable disconnected/Ethernet fault)
ETH3	Network Interface(NET) Left/Green – Blinking (data activity), Solid (ready), Off (no link/cable disconnected/Ethernet fault) Right/Green (1000Base-T link speed), Right/Orange (100BaseT link speed), Right/Off (no link/cable disconnected/Ethernet fault)
ETH4	Network Interface(NET) Left/Green – Blinking (data activity), Solid (ready), Off (no link/cable disconnected/Ethernet fault) Right/Green (1000Base-T link speed), Right/Orange (100BaseT link speed), Right/Off (no link/cable disconnected/Ethernet fault)

Port	Description
Serial	Serial Interfaces 1-8 Right/Orange DCD/DTR – On (port open and/or cable connected), Off (not ready) Left/Green RX/T – Blinking (data activity), Off (no activity)

## Nodegrid Link SR

The Nodegrid Link SR brings agility to the branch network and packs tremendous power in a compact design. Truly robust and dynamic, secure infrastructure management. Configure and manage Link SR via the ZPE Cloud to get your Branch / IoT / M2M / Kiosk / ATM / Remote Locations up and running quickly and easily.



Features include:

- Secure, fast and consistent deployments across your branches with the ZPE Cloud
- Combines Cellular gateway and WiFi Access Point (AP) with power input via PoE or Power Adapter
- Software Defined Networking, Network Function Virtualization, Guest OS, Kubernetes, and Docker capabilities
- Minimizes MTTR, downtime and expenses with secure, centralized remote device access & control
- Increases site reliability with open industry standard hardware, and easy-to-use software

- Zero Touch Provisioning (ZTP) for fast and easy setup in remote locations
- Integrates with ZPE Cloud and ZPE Systems Nodegrid Manager vendor-neutral, unified management solution
- Direct Linux shell, HTML5 cross-device web access and command line interface
- Modern 64-bit Linux Kernel for fast security patching and widespread software availability
- Kubernetes and Docker-optimized for quick, flexible script and application integration
- Extended Automation based on actionable real-time data
- Failover to 4G/LTE modem
- Linkway and multi-routing table capability
- VPN and IPsec
- DHCP server – extra IPs for your remote site or replace your current router altogether
- Firewall – built-in and turns on with a checkbox
- Secure – selectable encrypted cryptographic protocols and cypher suite levels, configuration checksum™
- Power control and monitoring – get alerts on suboptimal IT device health before malfunctions occur and solve problems automatically
- Orchestration - Puppet, Chef, Ansible, RESTful and ZPE Cloud
- High density and flexible interfaces for greater connectivity

**Nodegrid Link SR Hardware Specifications**

Item	Description
CPU	Intel Multi-core x86_64 CPU
Memory & Storage	4-8GB of DDR3 DRAM 16GB Self Encrypted Disk (SED) 32 GB SATADOM SSD (Upgradeable)
Interfaces	1 RJ45 Serial ports 1 SFP (1G) 1 Gigabit (10/100/1000BT) Ethernet interfaces on RJ45 with PoE in 2 GPIO Port (Digital I/O TTL level 5.5V max @ 64mA) 2 Digital Out Port (Signal MOSFET Digital Output 2.5V to 60V @ 500mA max) 2 USB 2.0 Hosts on Type A 1 Wi-Fi (optional) 1 Cellular Slots with Dual SIM (optional) 1 VGA port

Item	Description
Power	10V - 57VDC power input AC Power adapter (add-on) 100-240V~ 50-60Hz 1.5A PoE power input Power consumption 15 W typical
Physical	DIM Rail and Wall Mountable Size (L x W x H): 170 130 55 mm (6.69 x 5.11 x 2.16 in) Weight: 1.58 kg (2.3 lb) Shipping weight: 1.58 kg (3.5 lb) Shipping (L x W x H): 228.6 x 342.9 x 88.9 mm (9 x 13.5 x 3.5 in)
Environmental	Operating: 0 to 60°C (32 to 140° F), 5-95% RH, non-cond. Storage: -20 to 67° C (-4 to 153° F), 10-90% RH, non-cond.

**Nodegrid Link SR Top View**

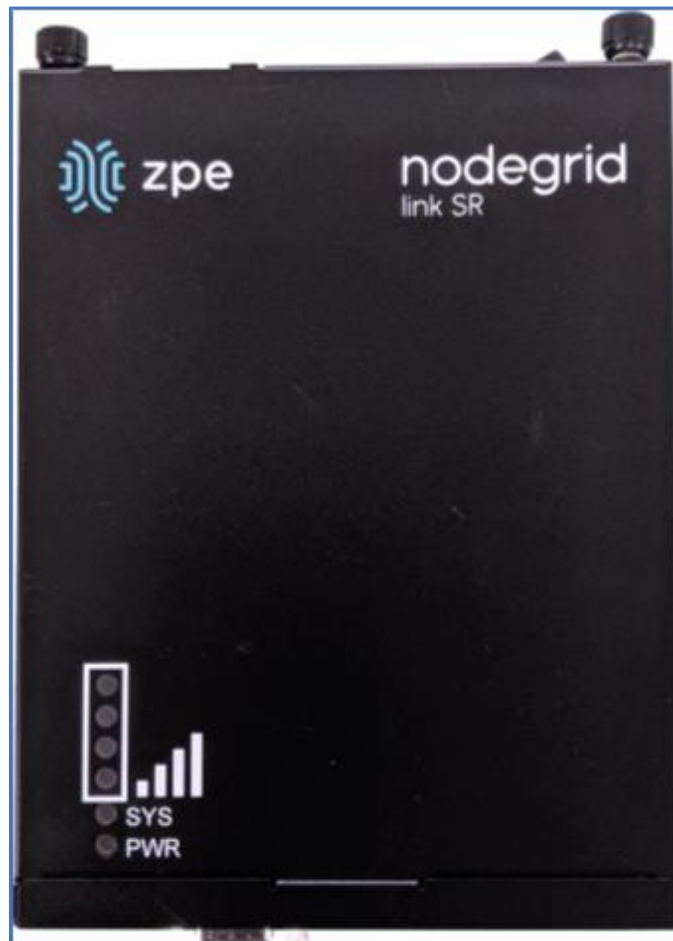

Designation	Description
BARS	Signal Strength indicator

Designation	Description
PWR	Power LED Green:- Solid - normal- Off - power is off
SYS	System LED Green:- Blinking - normal- Fast Blink - RST button Acknowledgment- Off or Solid - no activity

### Nodegrid Link SR Front Interfaces



Designation	Description
SFP 0	SFP Network Interface 0 Left/Yellow – Blinking (data activity), Solid (link up), Off (no link/cable disconnected) Right/Green – Solid (1000Base-T link speed), Off (no link/cable disconnected)
Serial	Serial Interface 1- Right/Orange DCD/DTR – Solid (port open and/or cable connected), Off (not ready) Left/Green RX/T- Blinking (data activity), Off (no activity)
Console	Console MGMT Interface
USB	2 USB 2.0
VGA	Monitor Interface

### Nodegrid Link SR Rear Interfaces



Item	Description
Power Switch	Power on/off Switch
V1- / GND / V1+	Power Connector for External Power Supply: 10V - 57VDC power input
ETH0	1 Gigabit (10/100/1000BT) Ethernet with PoE in Left/Yellow – Solid (link up), Blinking (data activity), Off (no link/cable) Right/Green - Solid: (1000Base-T link speed), Off (10/100BaseT link speed)
DIO0	Digital I/O TTL level 5.5V ma @ 64mA
DIO1	Digital I/O TTL level 5.5V ma @ 64mA
OUT0	Signal MOSFET Digital Output 2.5V to 60V @ 500mA max
OUT1	Signal MOSFET Digital Output 2.5V to 60V @ 500mA max
RST	Reset button:<3s system reset>10s reset to factory default and system reset

### Nodegrid Mini SR

The Nodegrid Mini SR is a miniature PC designed to be tough, capable, versatile and user-friendly. The unique fan-less design eliminates the need for any maintenance after installation. The device is designed to minimize size and maximize capabilities, durability and thermal performance.



### Nodegrid Mini SR Hardware Specifications

Item	Description
CPU	Intel Apollo Lake CPU
Memory & Storage	1x SO-DIMM 204-pin DDR3L SDRAM Up to 16 GB RAM eMMC   M.2 SATA   2.5" storage*
Interfaces	1 HDMI 1.4b up to 3840 x 2160 @ 30Hz 1 Display Port 1.2 up to 4096 x 2160 @ 60 Hz (via Mini DP connector) 1 LAN1: Intel I211 GbE controller (RJ-45) 1 LAN2: Intel I211 GbE controller (RJ-45) 2 USB 3.0 2 USB 2.0 1 Serial communication ports 1 COM1: RS232 via mini serial connector
Power	Unregulated 7 - 20VDC input Power consumption 5W to 15W depending on configuration and system load
Physical	Size (L x W x H): 112 mm X 84 mm X 34 mm (4.41 x 3.31 x 1.34 in) Weight: 0.35 kg (0.77 lb) Shipping weight: 0.91 kg (2 lb) Shipping (L x W x H): 305 x 127 x 63.5 mm (12 x 5 x 2.5 in)

Item	Description
Environmental	Operating: 0 to 45°C (32 to 113° F), 5-95% RH, non-cond. Storage: -20 to 67° C (-4 to 153° F), 10-90% RH, non-cond.

### Nodegrid Mini SR Rear Interfaces



Designation	Description
USB	2 USB 2.0
USB	2 USB 2.0
HDMI	1 HDMI 1.4b up to 3840 x 2160 @ 30Hz
Mini DP	1 Display Port 1.2 up to 4096 x 2160 @ 60 Hz (via Mini DP connector)
DC In	DC Power In connector (Unregulated 7 - 20VDC input)
RS232	COM1: RS232 via mini serial connector
LAN1	1 LAN1: Intel I211 GbE controller (RJ-45)
LAN2	1 LAN2: Intel I211 GbE controller (RJ-45)



### Nodegrid Mini SR Front Interfaces



Item	Description
Power button	Power on/off Switch
USB 3.0	USB 3.0 connector
Line-in	
Line-out	
LED1	Yellow – Solid (link up), Blinking (data activity), Off (no link/cable) Green – Solid: (1000Base-T link speed), Off (10/100BaseT link speed)
USB 3.0	USB 3.0 connector.
LED2	Yellow – Solid (link up), Blinking (data activity), Off (no link/cable) Green – Solid: (1000Base-T link speed), Off (10/100BaseT link speed)

## Nodegrid Manager

The Nodegrid Manager provides you with a unified solution to control compute, network, storage, and smart power assets.

### Nodegrid Manager Hardware Requirements (physical or virtual devices)

Item	Description
CPU	Minimum: two cores, x86_64 CPU
Memory & Storage	4 GB RAM, minimum 32 GB HDD
Interfaces	Minimum 1 Gigabit Ethernet interface
Supported Hypervisors	VMWare ESX LinuKVM Oracle Virtualbo-- LinuOS



# Installation





## Hardware Installation

Refer to the “Quick Install Guide” provided with the boxed unit.

### Shipping Box Contents

#### Accessories

Model	Mounting brackets	Power cables	Loop-back adapter	Console adapter	Network cable	Quick start guide & safety sheet
Nodegrid Serial Console - T Series	Yes	Yes	Legacy 	Z000036	Yes	Yes
Nodegrid Serial Console - R Series - TxxR	Yes	Yes	Cisco 	Z000014	Yes	Yes
Nodegrid Serial Console - S Series - TxxS	Yes	Yes	Legacy/Cisco 	Z000015Z000036	Yes	Yes

Model	Mounting brackets	Power cables	Loop-back adapter	Console adapter	Network cable	Quick start guide & safety sheet
Nodegrid Net Services Router	Yes	Yes	Cisco 	Z000014	Yes	Yes
Nodegrid Bold Services Router	Yes	External Power Supply	Cisco 	Z000014	Yes	Yes
Nodegrid Link Services Router	No	Optional External Power Supply	Cisco 	Z000014	Yes	Yes
Nodegrid Gate Services Router	Yes	Optional External Power Supply	Cisco 	Z000014	Yes	Yes

Each unit is shipped with multiple accessories. The table below lists the contents of the box.

### **Installation of Modules for Nodegrid Net Services Router**

The Nodegrid Net Services Router supports a variety of different modules. All modules are not hot-swappable and need to be installed before the unit is powered up. The modules should be installed in an ESD protected environment to avoid damage. To install a card, follow the steps below:

1. Ensure that the Nodegrid Net Services Router is powered off.
2. Turn off the power supplies on the Nodegrid Net Services Router.
3. Unscrew the blanking panel which covers the slot in which the module should be installed.
4. Unbox the card and insert it into the appropriate slot.
5. Fix the card with the provided screws.
6. The Nodegrid Net Services Router can now be turned on.

**NOTE:** The blanking panel should be kept for later use. For thermal efficiency and safety, each unused slot needs to be covered with a blanking panel.

## Module Compatibility Layout

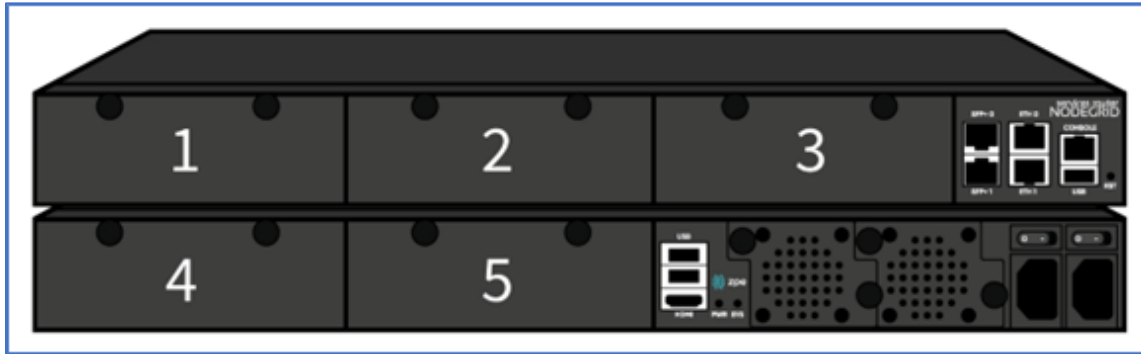

**Nodegrid Net Services Router Expansion Module Compatibility Chart**

Expansion card	Slot 1	Slot 2	Slot 3	Slot 4	Slot 5
16-Port GbE Ethernet	✓	✓	✓	Secure Isolated Mode **	Secure Isolated Mode **
16-Port SFP	✓	✓	✓	Secure Isolated Mode **	Secure Isolated Mode **
16-Port Serial	✓	✓	✓	✓	✓
16-Port USB	✓	✓	✓	✓	✓
M.2 Cellular / WiFi	✓	✓	✓	✓	✓
8-Port SFP+	✓	✓	✓	Secure Isolated Mode **	Secure Isolated Mode **
8-Port POE+	✓	✓	✓	–	–
Compute	✓	✓	✓	Secure Isolated Mode **	Secure Isolated Mode **
Storage *	–	–	–	✓	✓
M.2 SATA *	–	–	–	✓	✓

### NOTES:

(\*) The Nodegrid Net Services Router supports a maximum of 2 SATA drives, which can be divided into 2 Storage cards or in one M.2 SATA card.

(\*\*) The Secure Isolated Mode allows for the management of the cards as if they would be located in a normal Slot, but the network traffic is isolated from any other slot.

### ***M.2 Cellular Antenna Placement***

Correct antenna placement is critical to ensure proper functionality of the M.2 Cellular expansion card. Two antennas (main and auxiliary) are required for each card and should be separated to improve signal quality.

## Single Card Configuration

For single card applications, antenna placement is as follows:

### Channel A

Main in slot 1

Auxiliary in slot 6

The A and B channel strength indicators do not directly correspond to the antenna slot positions (Slots 4-6 are not specifically reserved for channel B).

## Dual Card Configuration

For dual card applications, four antennas (2 main and 2 auxiliary) will be used. Antenna placement is as follows:

### Channel A

Main in slot 1

Auxiliary in slot 4

### Channel B

Main in slot 3

Auxiliary in slot 6

## Device Power Connections

### DC Power

DC power is connected to DC-powered equipment with three wires: Return (RTN), Ground and 48 VDC.

**WARNING:** It is critical that the power source supports the DC power requirements of your Nodegrid. Make sure that the power source is the correct type and that the DC power cables are in good condition before proceeding. Failure to do so could result in personal injury or damage to the equipment.

**WARNING:** Wiring to power from a DC supply may be confusing, especially in telecom racks, where the supply's positive wire (usually of red color) goes to the ground, and the hot wire (usually of black color) carries the -48VDC. In case of any doubt, consult a certified electric technician before proceeding with connections. Failure to do the right connections could result in personal injury or damage to the equipment.

### Dual DC Power Connection Terminal Block

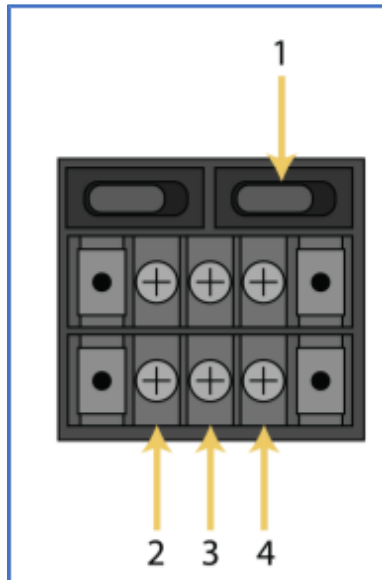

**DC Power Block Terminals**

Number	Description
1	Power Switch
2	RTN (Return)
3	Ground
4	48 VDC

### DC association - terminal power source and switch

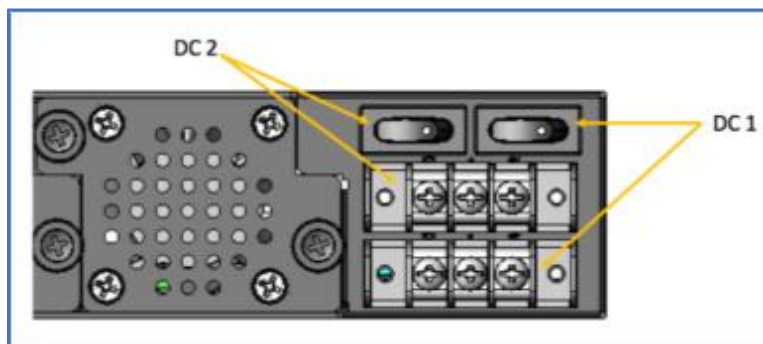

## NSR Single DC + PoE Power Connection Terminal Block

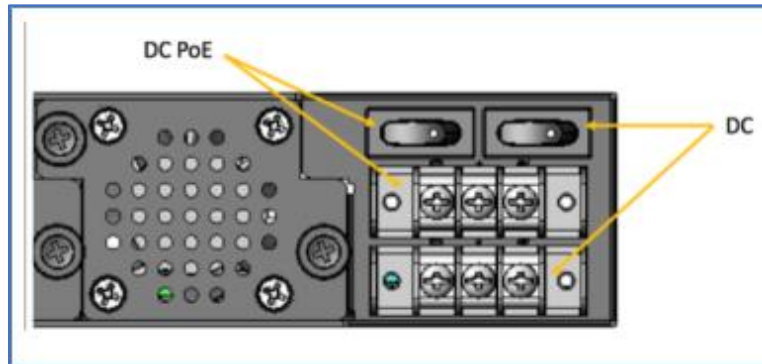

### Connect a Nodegrid device to DC Power

1. Make sure the device is turned off.
2. Make sure DC power cables are **not** connected to a power source.  
**Never work on powered wires.**
3. On the DC power block, remove the protective cover. (Slide to the left or right to remove.)
4. Loosen all three DC power connection terminal screws.  
Connect return lead to the RTN terminal.  
Connect ground lead to the GND  $\perp$  terminal.  
Connect 48 VDC lead to the 48 VDC terminal.
5. Tighten the screws.
6. Slide the DC terminal block protective cover back into place.
7. If device has dual-input DC terminals, repeat DC power connection steps for the second terminal block.
8. Connect the DC power cables to the DC power source.
9. Turn on the DC power source.
10. (optional) Connect a serial client (set as 115200 8N1) to the console port (Teraterm, puTTY, etc).
11. Turn power on to the serial client.
12. On the connected serial client, double-check booting messages.
13. For the connected devices, turn on the power switches.
14. Connect the DC power cables to the DC power source.
15. Turn on the DC power source.
16. Turn on the unit.
17. Turn on the power switches of the connected devices.

**-48VDC supply**

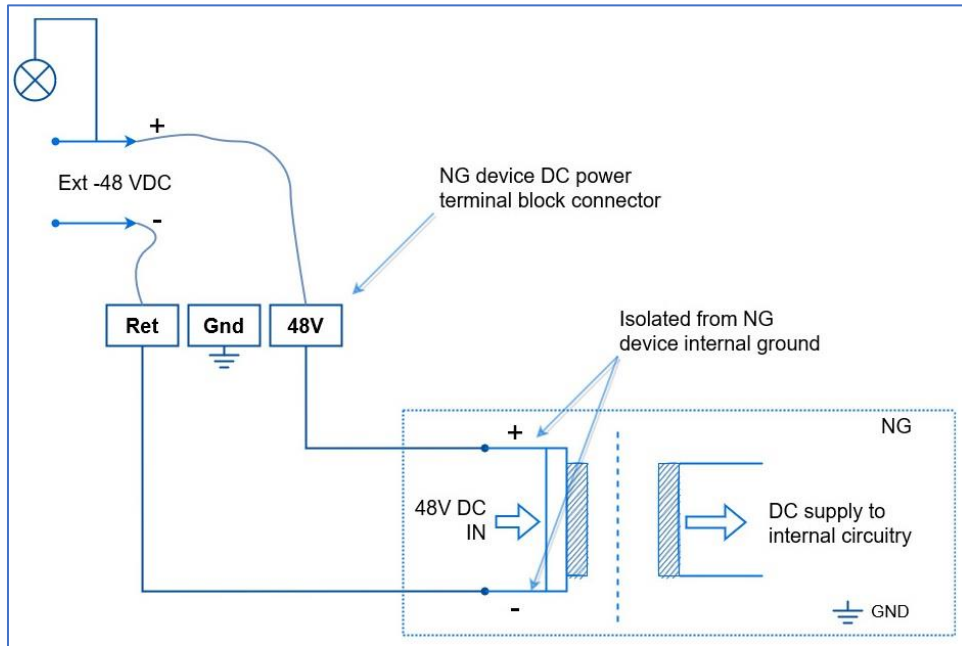

**+48VDC supply**

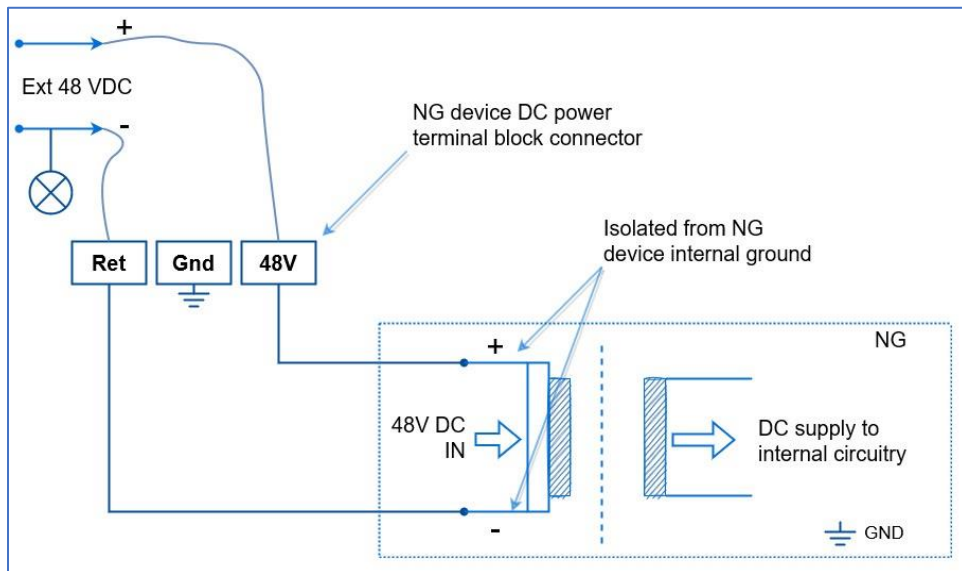

**AC Power**

This is the AC diagram for the NSR models with PoE+ support.



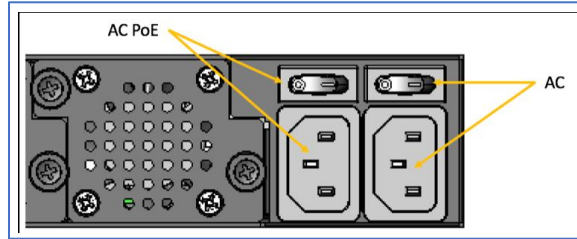





## Rack Mounting

All units shipped with rack mounting brackets can be mounted to fit a standard 19" rack. Two rack mounting brackets are provided in the box as outlined in the What is in the box section. The remainder of this document will refer to "rack or cabinet" as "rack".

Some units are actively cooled by fans. These units must be properly mounted into the rack to ensure the fans blow into the correct direction. The fan direction can be determined from the part number of the unit.

### Rack Mounting

Model	Part Number	Cooled	Airflow
Nodegrid Serial Console - T Series	NSC-Txx-xxxx-xxx	Passive	N/A
Nodegrid Serial Console - R Series	NSC-TxxR-xxxx-xxx	Passive	N/A
Nodegrid Serial Console - S Series	NSC-TxxS-xxxx-xxx-F	Active	Front-Back (air in) 
Nodegrid Serial Console - S Series	NSC-TxxS-xxxx-xxx-B	Active	Back-Front (air out) 
Nodegrid Net Services Router	NSR-xxxx-xxx	Active	Front-Back (air out) 
Nodegrid Net Services Router	NSR-xxxx-xxx	Active	Back-Front (air in) 

Model	Part Number	Cooled	Airflow
Nodegrid Bold Services Router	BSR-xx-xxxx	Passive	N/A
Nodegrid Link Services Router	LSR-xx-xxxx	Passive	N/A
Nodegrid Gate Services Router	GSR-xx-BASE	Passive	N/A
Nodegrid Gate Services Router	GSR-xx-UPGx	Active	Front-Back (air out)

## Rack Installation

1. Install the rack mounting brackets with the provided screws as shown in the diagrams below

### Nodegrid Serial Console

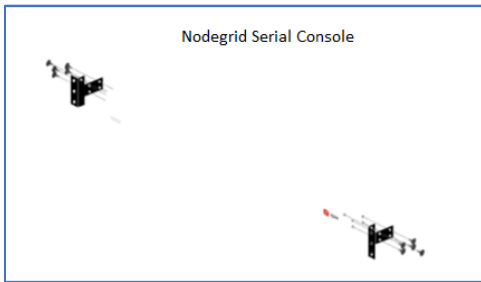

### Nodegrid Net Services Router

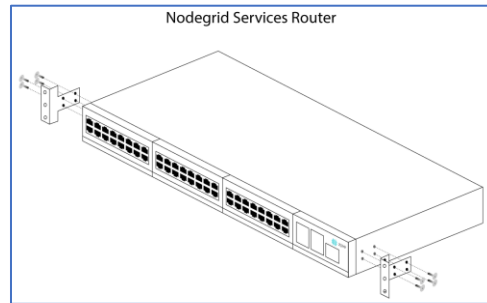

### Nodegrid Bold SR

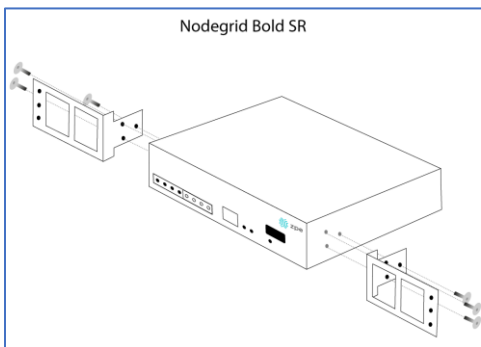

### Nodegrid Link SR

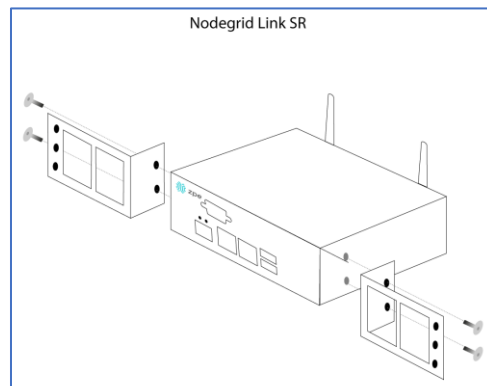

### Nodegrid Gate SR

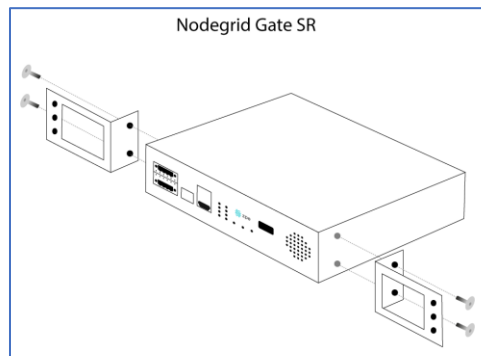

2. Locate the position on the rack where you would like to mount the unit and ensure the slot is clear of any obstructions.
3. Slide the unit into the rack and align the mounting bracket screw holes with the screw holes on the rack as shown below:

### Nodegrid Serial Console

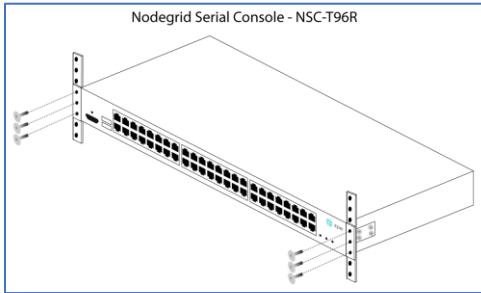

### Nodegrid Net Services Router

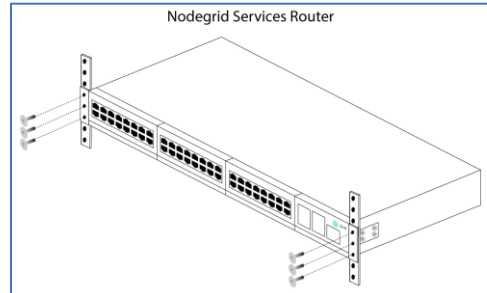

### Nodegrid Bold SR

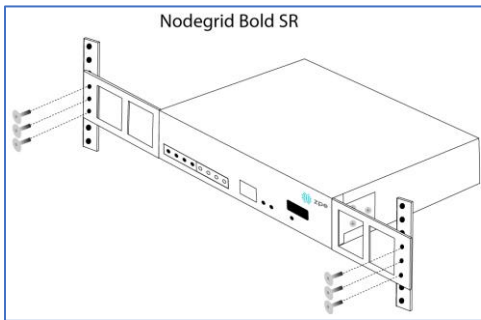

### Nodegrid Link SR

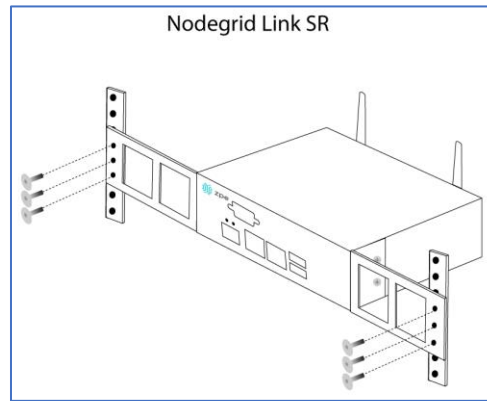

### Nodegrid Gate SR

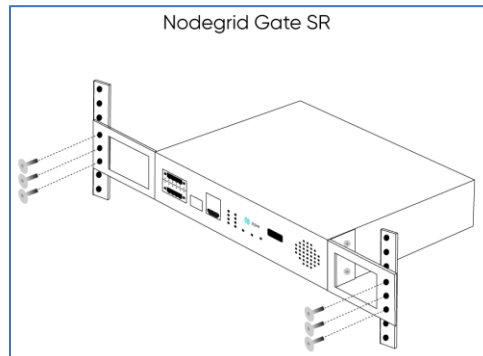

4. While holding the unit in position, insert the rack mount screws (not included) and turn them clockwise until they are snug, but not tight.
5. Once all the screws are installed, check to ensure that the unit is supported and still in the correct position.
6. Tighten the screws securely in place to complete the installation.

## Network Connection

Depending on model and version, the unit has a minimum of two copper Ethernet ports or two SFP+ ports. Connect the proper network cables (CAT5e, CAT6, CAT6A) from the network switch port to any available unit network ports. For models with SFP+ ports, before the unit is turned on, install the SFP+ module and connect the appropriate cables.

## Power Cord(s) Connection

The Nodegrid unit can have one or multiple power supplies (AC or DC). Connect all the power supplies with appropriate cables to an available power source (usually a Rack PDU. If the unit was shipped with one power supply, that unit has no power failure redundancy. Units with two power supplies provide redundancy against power failures. Make sure these power supplies are connected to two independent power sources.

**NOTE:** On the Nodegrid Net Services Router with PoE support, the second power supply specifically powers the PoE feature – and does not provide power outage redundancy.

When all power supplies are appropriately connected to a power source, power can be turned on.

## Connect Devices

### Serial Devices

**NOTE:** To avoid EMC issues, always use good quality network cable for all port connections.

The cabling and adapters needed between the unit serial ports and the serial devices' console port are determined by their pin-outs.

Newer serial devices (routers, switches, and servers) use either a DB9, RJ45 or USB port as console ports. See the manufacturer's manual for serial device port pin-out specs. Generally, the RJ45 console port uses the Cisco-like pin-out.

**Required Cabling Ports/Pin-outs**

Model	Port type	Pin-out	Device port - RJ45 (Legacy)	Device port - RJ45 (cisco)	Device port - DB9	Device port - USB
Nodegrid Serial Console - T Series	RJ45	Legacy	CAT5e cable	CAT5e cable plus Z000039 crossover adapter	CAT5e cable plus Z000036 crossover adapter	USB
Nodegrid Serial Console - R Series	RJ45	Cisco	-	CAT5e cable	CAT5e cable plus Z000015 crossover adapter	USB
Nodegrid Serial Console - S Series	RJ45	Auto-Sensing (Legacy/Cisco)	CAT5e cable	CAT5e cable	CAT5e cable plus Z000015 crossover adapter	USB

Model	Port type	Pin-out	Device port - RJ45 (Legacy)	Device port - RJ45 (cisco)	Device port - DB9	Device port - USB
Nodegrid Net Services Router	RJ45	Cisco	-	CAT5e cable	CAT5e cable plus Z000015 crossover adapter	USB
Nodegrid Bold Services Router	RJ45	Cisco	-	CAT5e cable	CAT5e cable plus Z000015 crossover adapter	USB
Nodegrid Link Services Router	RJ45	Cisco	-	CAT5e cable	CAT5e cable plus Z000015 crossover adapter	USB
Nodegrid Gate Services Router	RJ45	Cisco	-	CAT5e cable	CAT5e cable plus Z000015 crossover adapter	USB

If the serial device's RJ45 does not have the Cisco-like pin-out, or there is a question on connecting a serial device to the unit, contact [ZPE Systems Technical Support](#) for assistance.

## IP Devices

**NOTE:** To avoid EMC issues, always use good quality network cable for all port connections.

All IP based devices are directly connected to a network interface on a Nodegrid unit; or connected through an existing network infrastructure. If devices are directly connected, use standard network cables (CAT 5, CAT6, CAT6e) for Ethernet connections, or an appropriate fiber cable.

## Connect to a Nodegrid Device

On the first connection to a Nodegrid device, the login prompt requires an immediate password change.

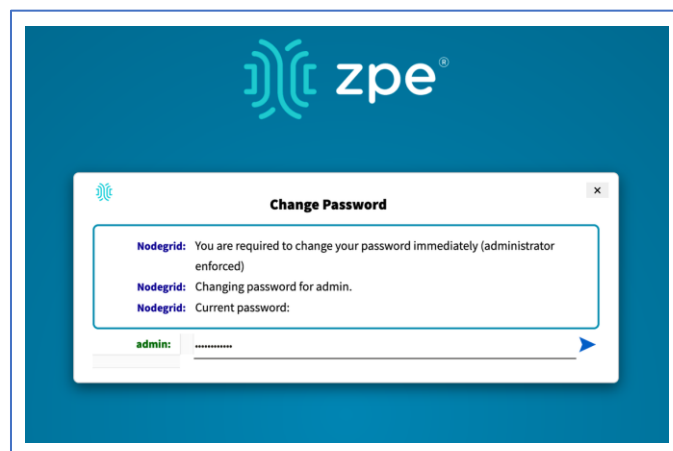

**NOTE:** On new devices, SSH is disabled by default.

## Connect to the Console Port

Use the provided CAT5e and RJ45-DB9 Z000036 adapter/cable to communicate with the Nodegrid unit.

1. Connect one end of the CAT5e cable to the Nodegrid console port.
2. Connect the other end to the RJ45-DB9 adapter.
3. Plug the adapter into the PC's DB9 COM port.  
If no DB9 COM port, use a USB-DB9 adapter (not provided).
4. On the PC, use a serial application (Xterm, TeraTerm, PuTTY, SecureCRT) to open a terminal session to the COM port:
5. Set it to: 115200bps, 8 bits, no parity, 1 stop bit, no flow control settings.

**NOTE:** See system information to find the COM port.

## ETH0 Connection

By default, the ETH0 interface is configured to listen for DHCP requests. If no DHCP Server is available, the unit uses the default IP address: 192.168.160.10. Use a browser to access the unit: [https://\[DHCP ASSIGNED IP\]](https://[DHCP ASSIGNED IP]) or <https://192.168.160.10>. If needed, a SSH client can be an alternative access.

### Connection through ETH0

Setting	Value
DHCP	enabled
Fall-back IP	yes
Default IP	192.168.160.10/24
Default URL	<a href="https://192.168.160.10">https://192.168.160.10</a>
Default SSH	SSH admin@192.168.160.10
DHCP	enabled

## WiFi Connection

The Nodegrid device is pre-configured to act as a WiFi hotspot with a built-in WiFi module or a USB WiFi adapter. When turned on, the device automatically presents a WiFi network with the SSID = **Nodegrid**. The password is the device's serial number.

The Nodegrid device provides the IP address to clients in the network 192.168.162.0/24. The client can be configured statically with a valid IP address in the 192.168.162.<2-254> range, bitmask 24.

## Bluetooth® Connection

Zero Touch Provisioning (ZTP) via Bluetooth allows faster deployment, even when the network infrastructure is not in place. The only additional equipment needed is a smartphone or laptop with Bluetooth tethering enabled.

On Nodegrid devices configured with Bluetooth hardware, this is enabled by default. Bluetooth is enabled/disabled via the **Security** tab or **Network Settings**.

**NOTE:** For devices without Bluetooth, configure an adapter. Contact ZPE Support for the latest list of compatible adapters.

To connect via Bluetooth:

1. On your smartphone or laptop, enable tethering.
2. On the Bluetooth screen, locate and click on the new Nodegrid device.
3. Once paired, Nodegrid connects to the ZPE Cloud and automatically begins the ZTP process.

## KVM Port Connection

The Nodegrid unit can be directly configured with KVM.

1. Connect a HDMI cable to the monitor and the device's HDMI interface.

**NOTE:** The Nodegrid Bold SR uses a VGA port. If monitor only has HDMI, use a HDMI to DVI-D adapter to connect.

2. Connect a USB Keyboard and Mouse to the USB ports.

**NOTE:** The keyboard and mouse must support Linux. Windows-only devices are not supported. This limitation generally affects devices which use a USB wireless dongle.

3. The login prompt indicates the connection is active.

## I/O Ports (GPIO)

Nodegrid Gate SR supports two digital I/O ports (DIO0, DIO1), one digital output port (OUT0) and one relay port (1A@24V).

Nodegrid Link SR supports two digital I/O ports (DIO0, DIO1) and two digital output ports (OUT0, OUT1).

DIO0 and DIO1 can be independently configured as input or output. The DIO0 and DIO1 are open-drain digital I/O ports with TTL level (5.5V max @ 64mA). ESD protection exceeds JESD 22.

When DIO port is configured as input:

contact is open, senses High (1)

contact is closed, senses Low (0)

**NOTE:** DIO0 and DIO1 port configuration as input is ideal for dry contact applications (door close, vibration, water, smoke sensors).

When DIO port is configured as output:



set to high, outputs TTL high

set to low, outputs TTL low

**NOTE:** DIO0 and DIO1 port configuration as output can control low voltage/current applications.

The OUT0 and OUT1 are high voltage digital outputs. Each port is internally attached to a Signal MOSFET. The output port is normally open (NO) and capable of supporting a voltage range from 2.5V to 60V @ 500mA.

When OUT port is set to:

High (enabled/active and pulls OUT to ground)

Low (disabled/inactive and keeps OUT open)

**NOTE:** OUT0 and OUT1 can pull a power-connected line to ground (i.e., relay circuit).

On Nodegrid Gate SR, the RELAY port is normally a closed (NC) relay (rated max value of 24V @ 1A). The RELAY specification supports a maximum switching power of 60W, 125VA; maximum switching voltage of 220VDC, 250VAC; maximum switching current of 2A, with restive load.

The RELAY's primary function is a Power Source Control Alarm. When closed, it indicates that Nodegrid Gate SR is powered by a single power source or has no power. If the Nodegrid Gate SR is powered by both power input sources, when RELAY is closed, it indicates a FAILURE on at least one power input sources.

(optional), RELAY can be changed to follow software control (Open / Close), to control an external device. Possible relay states are:

open (opens relay contact)

close (closes relay contact)

The I/O Port configuration is under *System :: I/O Ports*. I/O Port status and other hardware details is under *Tracking :: HW Monitor*.

**WARNING!** For Safety Reasons, do not exceed max voltage or current defined on each port.

## Import / Export Configuration

The CLI can import the entire (or partial) Nodegrid configuration.

### Import Configuration Settings

```
import_settings [arguments]
```

where arguments can be:

--file <local-pathname> (local file input)

--overwrite-tables (overwrite table when its configuration is given)

--quiet (suppress report of success/failure per path, just output final counters)

**NOTE:** In interactive mode (no --file given), the lines can be typed or copied/pasted. Enter **<ctrl>D** to finalize.

## Export Configuration Settings

```
export_settings [cli-path] [arguments]
```

where arguments can be:

- with-options (provide a list of choices for value)
- include-empty (generate parameter line even if no value)
- not-enabled (generate parameter line even if parameter not active)
- plain-password (plain/hash password)
- file <local-pathname> (output to a local file)

## Nodegrid Manager Installation

Install Nodegrid Manager from an ISO file. This is the three-step process:

1. Create a virtual machine.
2. To install, boot from the ISO file/CD.
3. Restart and boot from the new virtual machine.

### Minimum Requirements:

- ESXi 4.1 or above
- 32 GB hard drive (connected through the LSI Logic Parallel Controller)
- 4 GB memory (8GB is recommended)
- 2 Network adapters (E1000 adapters are recommended)

### Create a VMware Virtual Machine

1. On the ESXi vSphere application, click **Create a new virtual machine**.
2. On the *Create a new virtual machine* dialog, click **Next**.

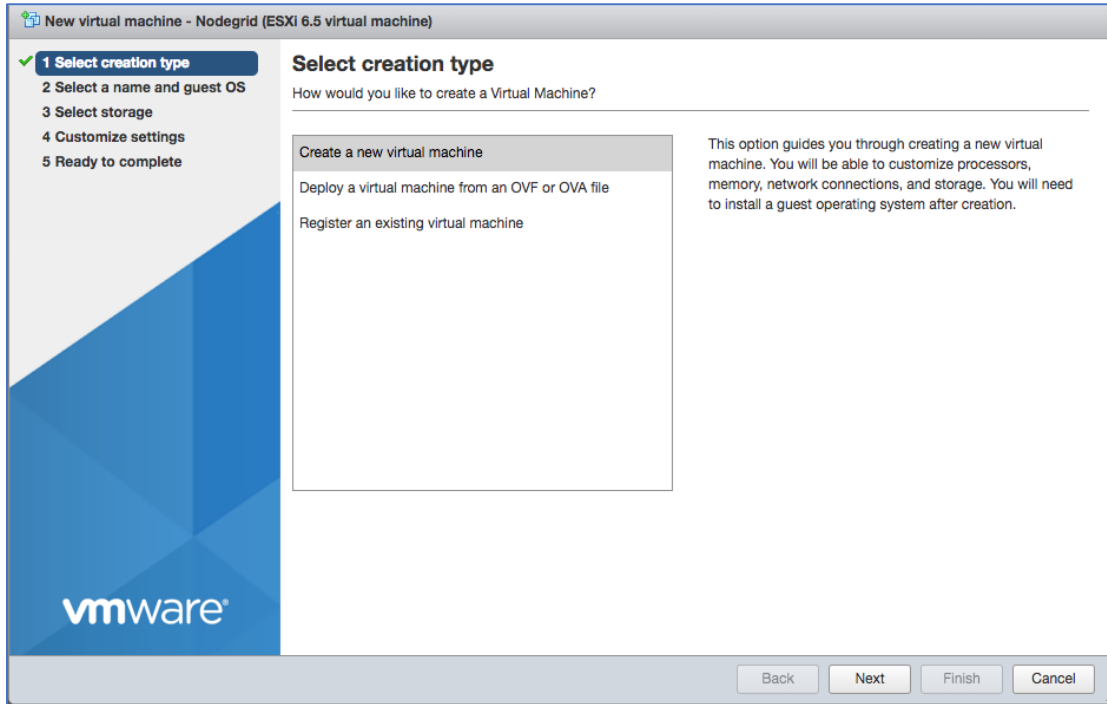

3. On *Select a name and guest OS* dialog:

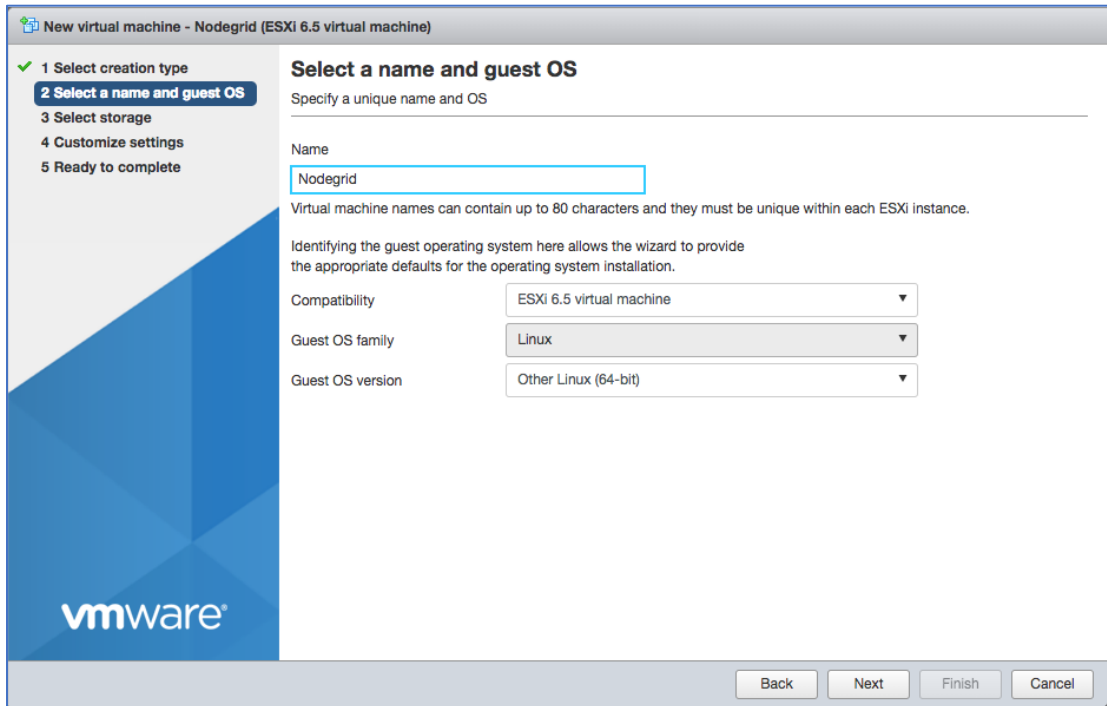

Enter **Name** for the Nodegrid Manager virtual machine.

For **Guest OS family**, select **Linux**.

For **Guest OS version**, select **Other Linux (64-Bit)**.

Click **Next**.

- On *Select storage* dialog table, select the virtual machine’s data storage volume. Click **Next**.

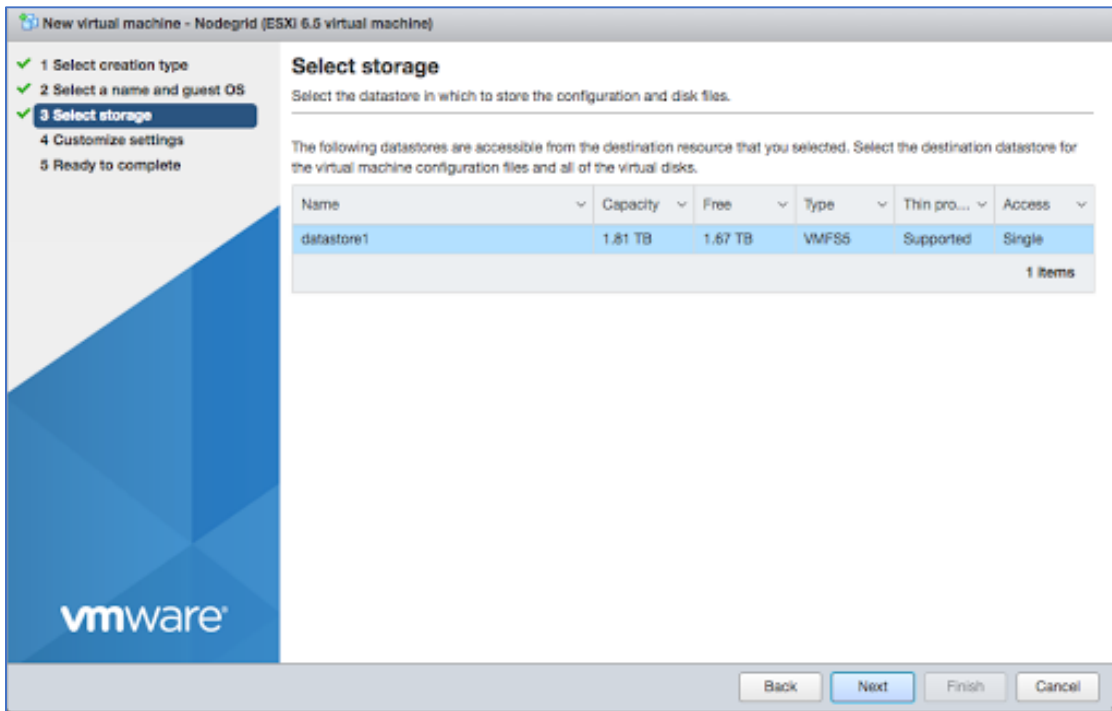

- On the *Customize settings* dialog, enter these settings (these are minimum settings – adjust as needed). Then click **Next**.

**CPU:** 2

**Memory:** 4GB

**Hard disk:** 32GB

**SCSI Controller:** LSI Logic Parallel

**Network adapters:** 2 of type E1000

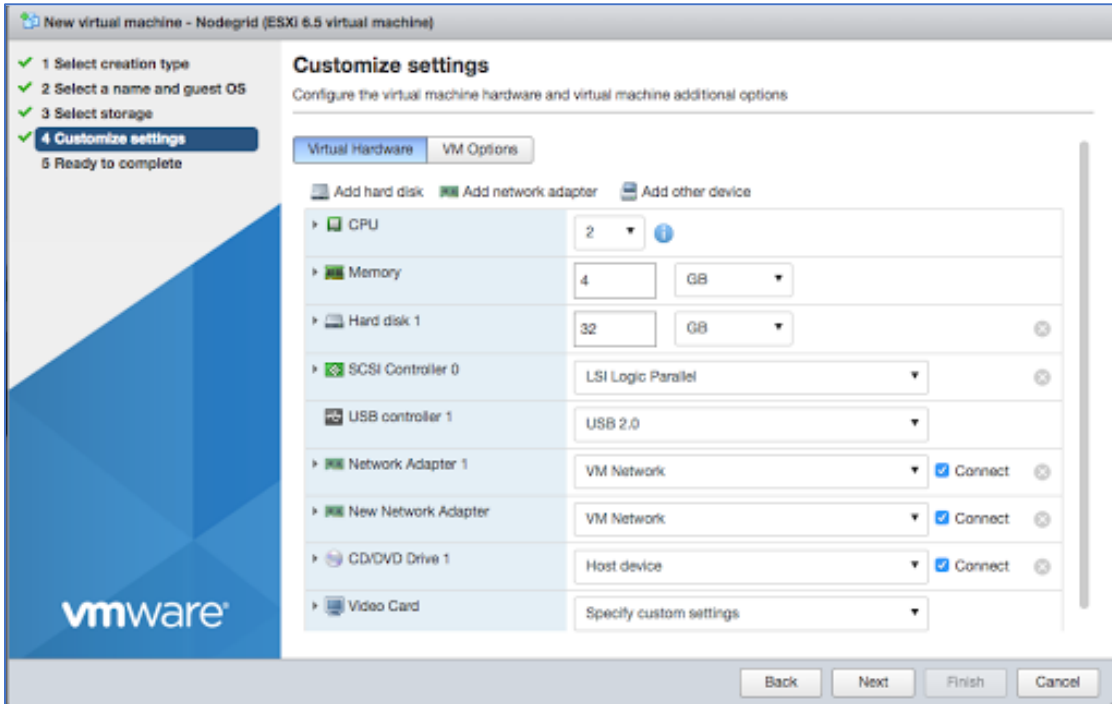

6. On the *Ready to complete* dialog, review the details. Click **Finish**

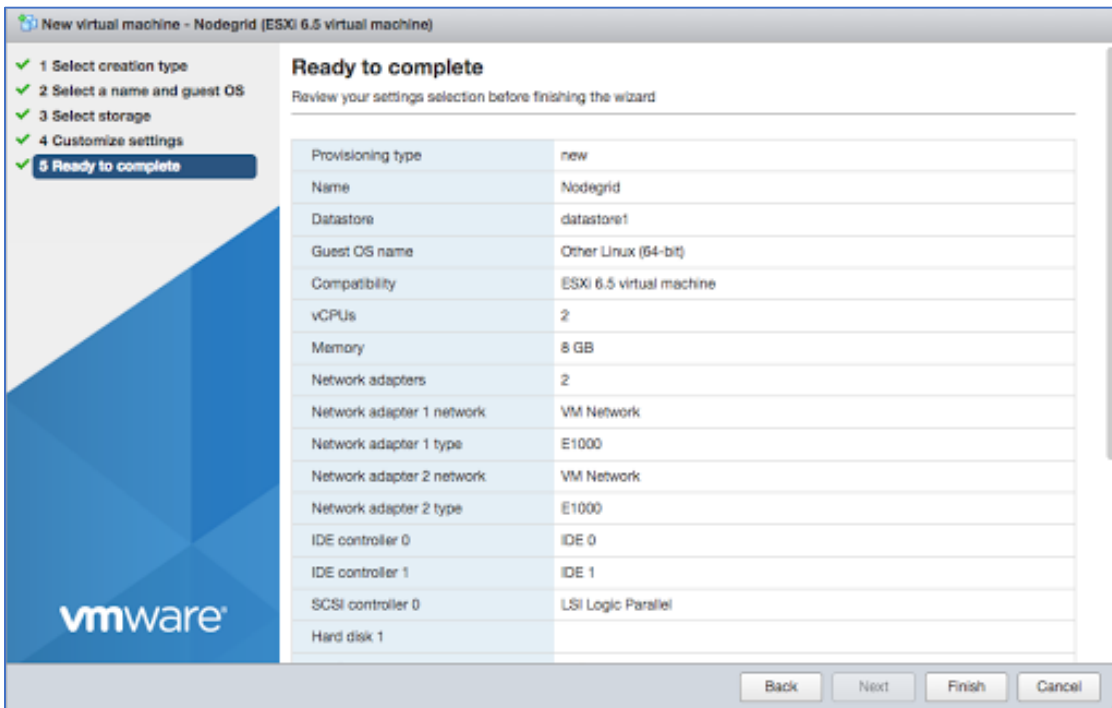

This completes the virtual machine configuration on the ESXi server.

### ***Install Nodegrid Manager***

To install the software:

1. On the virtual machine *Summary* screen, click the **Console** tab.
2. Turn on power to the virtual machine. Because there is no installed OS, the boot will fail.
3. Click on the CD/DVD icon and locate the Nodegrid Manager ISO file.
4. In the Console area, click CTL-ALT-INSERT. This reboots the virtual machine.
5. The virtual machine console server opens with a boot prompt. The image is decompressed and then loaded.
6. When the image boots, follow the console instructions. To accept the EULA, type **accept**.

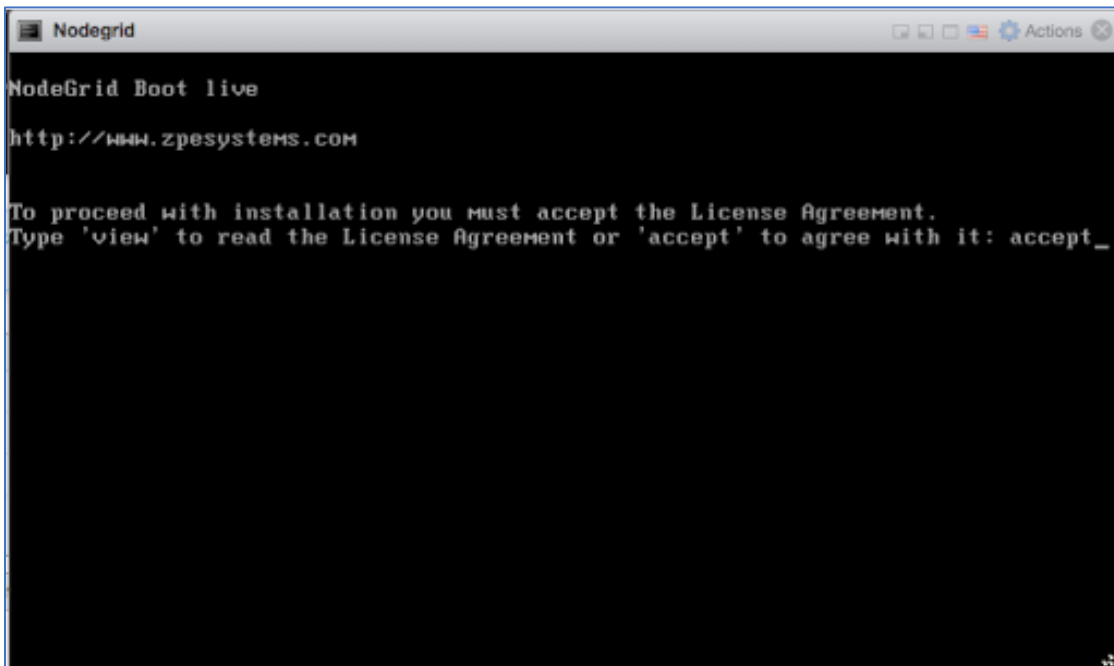

```
NodeGrid Boot live
http://www.zpesystems.com

To proceed with installation you must accept the License Agreement.
Type 'view' to read the License Agreement or 'accept' to agree with it: accept_
```

7. When complete, the virtual machine reboots.

```

Nodegrid
Disk /dev/sda: 34.4GB
Sector size (logical/physical): 512B/512B
Partition Table: msdos

Number  Start   End     Size    Type     File system  Flags
  1      1049kB  99.6MB  98.6MB  primary  ext4
  2      101MB   201MB   101MB   primary
  3      201MB   3202MB  3001MB  primary          boot
  4      3202MB  34.4GB  31.2GB  extended      lba
  5      3204MB  3304MB  99.6MB  logical
  6      3305MB  3315MB  9437kB  logical
  7      3316MB  3816MB  500MB   logical
  8      3817MB  34.4GB  30.5GB  logical

Checking current file system
Probe HD: Directory /var or root home directory not found.
Formatting partitions to ext4 ...
Mounting all partitions before start copy
Creating swap areas
Copying rootfs files...
Generating factory default settings files
Preparing second boot partition...
Installing grub on /dev/sda7
Remove your installation media, and press ENTER
  
```

- On reboot, the Nodegrid Manager application is ready to be configured.

```

Nodegrid
Booting 'NodeGrid Platform 4.0 Cirrus'

input_data: 0x00000000019ba276
input_len: 0x000000000429974
output: 0x0000000001000000
output_len: 0x000000000dd28c8
kernel_total_size: 0x000000000a6e000

Decompressing Linux... Parsing ELF... done.
Booting the kernel.
INIT: version 2.88 booting

Please wait: booting...
INIT: Entering runlevel: 5

Event Notification from nodegrid. Reported on 2018-08-02T11:48:33Z. Event ID 101
: The system has started.

NodeGrid 4.0.0 Feb 26 2018 - 04:46:01 nodegrid /dev/tty1 0.0.0.0
nodegrid login: _
  
```

## Enroll Nodegrid Manager to ZPE Cloud

### WebUI Procedure

- Log into ZPE Cloud.
- For enrollment information, go to *SETTINGS :: ENROLLMENT :: CLOUD*.
- Locate the device and open the WebUI.

4. Go to *Security :: Services* and select **Enable ZPE Cloud** checkbox.  
To enroll the device in one on-premise instance of ZPE Cloud, select **Enable Remote Access** checkbox.
5. Make other changes, as needed.
6. Click **Save**.
7. To enroll device, go to *System :: Toolkit* and click **Cloud Enrollment**. Enter **Customer Code** and **Enrollment Key**.  
To enroll the device in one on-premise instance of ZPE Cloud, enter **On-premise URL**.
8. Click **ENROLL**.

**CLI Procedure**

1. Log into ZPE Cloud.
2. For enrollment information, go to: *SETTINGS :: ENROLLMENT :: CLOUD*.  
Open the vSphere Client.  
On the **Menu** dropdown, select **Hosts and Clusters**.  
On the *Hosts and Clusters* list, select the Nodegrid Manager VM
3. Click **Launch Web Console**.
4. On the CLI, enter admin credentials.
5. To enable ZPE Cloud, enter:  

```
cd settings/zpe_cloud
set enable_zpe_cloud=yes
```

  
To enable the remote access feature, enter:  

```
set enable_remote_access=yes
commit
```
6. To complete, enter:  

```
commit
```

## System Profile

The system profile handle interactions between local network and remote network/internet. Two system profile configurations (OOB, Gateway) are available for the following devices.

**Device System Profile Configuration**

Device	WAN/Uplink	LAN
Hive SR	wan[0-1], sfp[0-1], wwan[0-1]	lan[0-3], wlan0
Bold SR	eth0, wwan[0-1]	net[0-3], wlan0



Device	WAN/Uplink	LAN
Gate SR	eth0, sfp[0-1], wwan[0-1]	net[0-7], wlan0
Link SR	eth0, wwan0	sfp0, wlan0

On these devices, two system profile options are: Out of Band Profile and Gateway Profile. Administrator can update the profile at *System :: Toolkit :: Restore to Factory Default Settings*.

**NOTE:** When set, the System Profile is persistent.

## Gateway Profile

When the System Profile selection is Gateway Profile, the following settings are configured:

- Block Unsolicited Incoming Packets enabled for all WAN ports
- IPv4 Forwarding and IPv6 Forwarding set to enabled
- Reverse Path Filtering set to Loose Mode
- Connection BRIDGE created for LAN interfaces
- Firewall rules and NAT rules are created
- If cellular card is detected:

Connection is created with name: CELLULAR-<channel>

Failover is enabled with these settings:

Primary Connection: ETH0 or WAN0

Secondary Connection: CELLULAR-<channel>

Trigger IP address: api.zpecloud.com

## Out of Band Profile

Out Of Band Profile is set with the following configuration:

- Block Unsolicited Incoming Packets set to disabled (all network connections)
- Network Settings configuration:
  - IPv4 Forwarding set to disabled
  - IPv6 Forwarding set to disabled
  - Reverse Path Filtering set to Restrict Mode
- Firewall rules created to allow traffic to/from "lo" device
- If cellular card detected, connection is not created
- Failover is disabled
- For hotspot, DHCP server is enabled

**NOTE:** If the device's DHCP server fails or is unavailable, Nodegrid Platform responds on ETH0 at 192.168.160.10

## Initial Network Configuration

### Access the CLI Window

On the Nodegrid Platform's CLI window, after the boot messages, the login prompt is displayed.

#### Admin user:

Initial username = **admin**

Initial password = **admin** (after first login, default password must be changed)

#### Super User:

Username = **root** (SHELL access to Linux OS, but not web interface)

Default password = **root**

### Identify Current IP Address

#### WebUI Procedure

1. Use admin login to device's Nodegrid Platform.
2. Go to *Network :: Connections*.

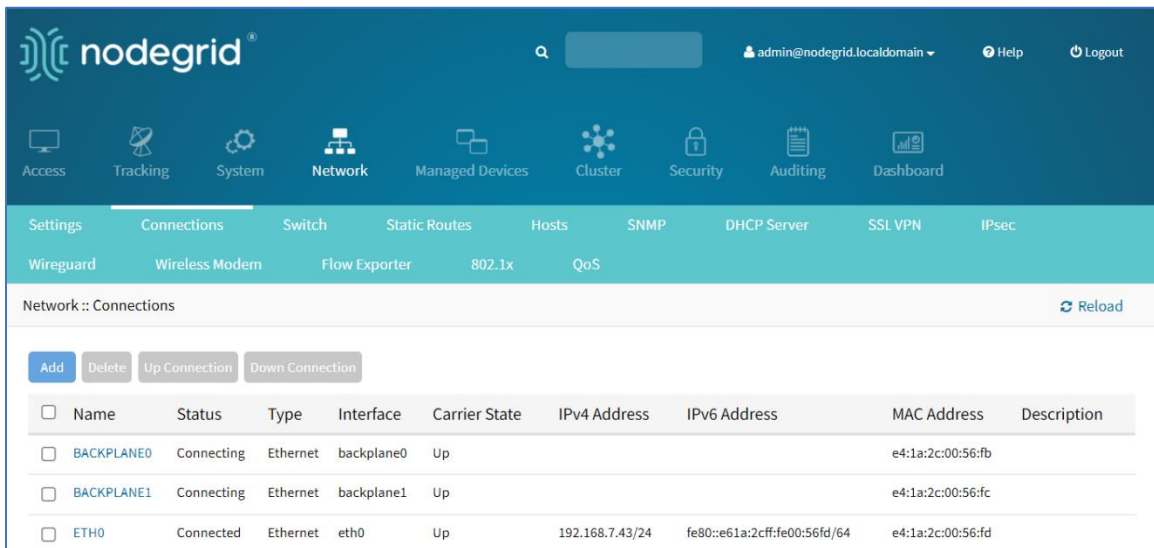

3. Review assigned IP addresses (save for later use).

#### CLI Procedure

1. Log into device as admin.
2. Enter:
 

```
show /settings/network_connections/
```

Example output:

```
[admin@nodegrid /]# show /settings/network_connections/
name          status      type        interface   carrier state  ipv4 address      ipv6
address       mac address description
=====
BACKPLANE0   connected  ethernet   eth0        up      192.168.10.252/24 fe80 ::
290:fbff:fe5b:72bc/64 e4:1a:2c:5b:72:bc ETH0        connected  ethernet   backplane0
up            192.168.29.3/24  fe80 :: 290:fbff:fe5b:72bd/64 e4:1a:2c:5b:72:bd
hotspot      not active  WiFi              down
```

### Define Static IP Address

If no DHCP server is available on the network, or to change from a dynamic to static IP, configure the network parameters.

**NOTE:** The examples below use IPv4 for communication. IPv6 is fully supported on the Nodegrid Platform. Settings are available in the same menus.

#### WebUI Procedure

1. Go to *Network :: Connections*.
2. Click on the Interface to be configured (displays dialog).

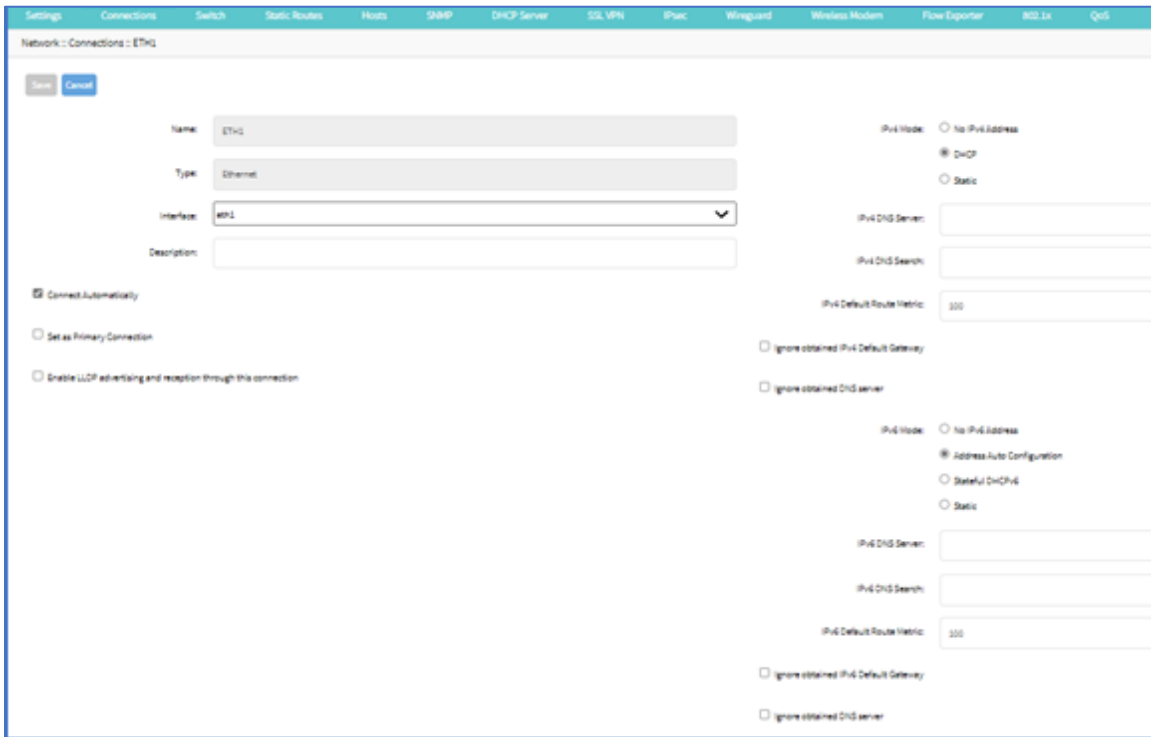

3. Enter the required details.
4. Click **Save**.

### CLI Procedure

1. Go to the desired network Interface:

```
cd settings/network_connections/ETH0/
```

2. Configure the Network interface:

```
set ipv4_mode=static
set ipv4_address=<IP_ADDRESS> ipv4_bitmask=<BITMASK> ipv4_gateway=<GATEWAY>
commit
```

Example:

```
[admin@Nodegrid /]# cd settings/network_connections/ETH0/
[admin@Nodegrid ETH0]# set ipv4_mode=static
[+admin@Nodegrid ETH0]# set ipv4_address=10.0.0.10 ipv4_bitmask=24
ipv4_gateway=10.0.0.1
[+admin@Nodegrid ETH0]# show
name: ETH0
type: ethernet
ethernet_interface = eth0
connect_automatically = yes
set_as_primary_connection = no
enable_lldp = no
ipv4_mode = static
ipv4_address = 10.0.0.10
ipv4_bitmask = 24
ipv4_gateway = 10.0.0.1
ipv4_dns_server =
ipv4_dns_search =
ipv6_mode = address_auto_configuration
ipv6_dns_server =
ipv6_dns_search =
[+admin@Nodegrid ETH0]# commit
[admin@Nodegrid ETH0]#
```

3. Follow the same steps for other interfaces.

## Configure Loopback Address

### WebUI Procedure

Multiple loopback addresses can be created with assigned IP addresses from within Network :: Connections.

1. Go to *Network :: Connections*.
2. Click **Add** (displays dialog).
3. On **Type** drop-down, select **Loopback** (modifies the UI).

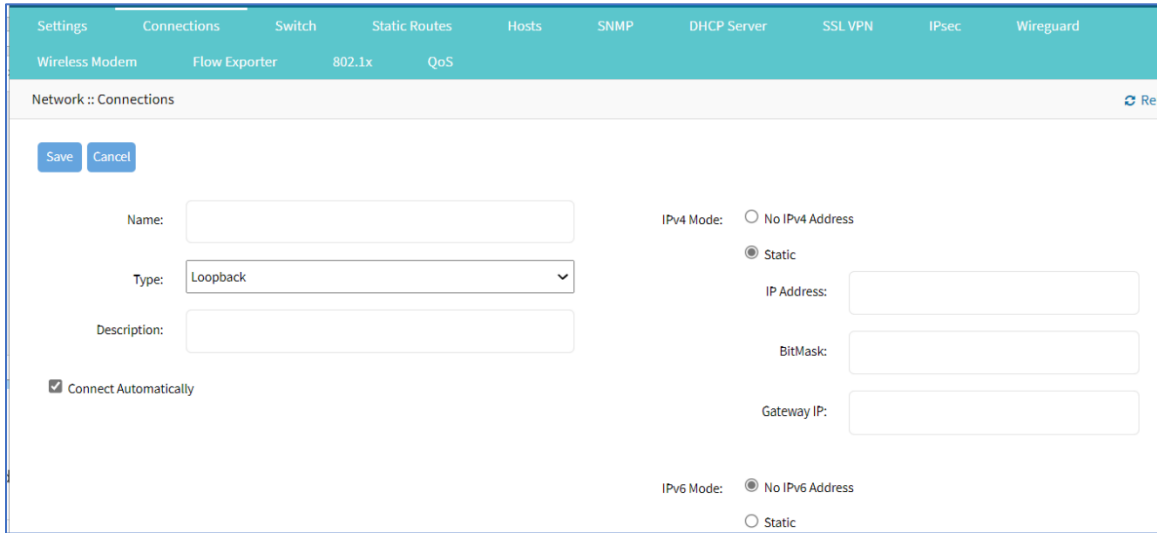

4. Enter required details.
5. Click **Save**.

### CLI Procedure

This is a minimal example. Other settings may be required (i.e., IP address is static or uses DHCP).

```
[admin@nodegrid /]# cd settings/network_connections/
[admin@nodegrid network_connections]# add
[admin@nodegrid {network_connections}]# set name=test
[admin@nodegrid {network_connections}]# set type=loopback
[admin@nodegrid {network_connections}]# commit
```

## WiFi Module

When the WiFi module is installed, Nodegrid automatically creates an SSID named “Nodegrid” on the 192.168.162.x/24 network with an IP address of 192.168.162.1. Any WiFi enabled device can be connected to this network to access the Nodegrid device.

**NOTE:** The device can also be accessed through the Internet with properly configured routing and network settings.

By default, a hotspot interface is defined which configures the device as an access point (if a WiFi module is present). To use the Nodegrid as an access point, update the values. The default password of the hotspot connection is the device serial number.

See [Add WiFi Interface](#)

### Connect Nodegrid Device to Another SSID

To connect the Nodegrid device to another client through any available SSID:

1. Go to *Network :: Connections*.
2. Click **Add** (displays dialog).

3. Enter **Name** (of the WiFi module).
4. On the **Type** drop-down, select **WiFi** (changes display).

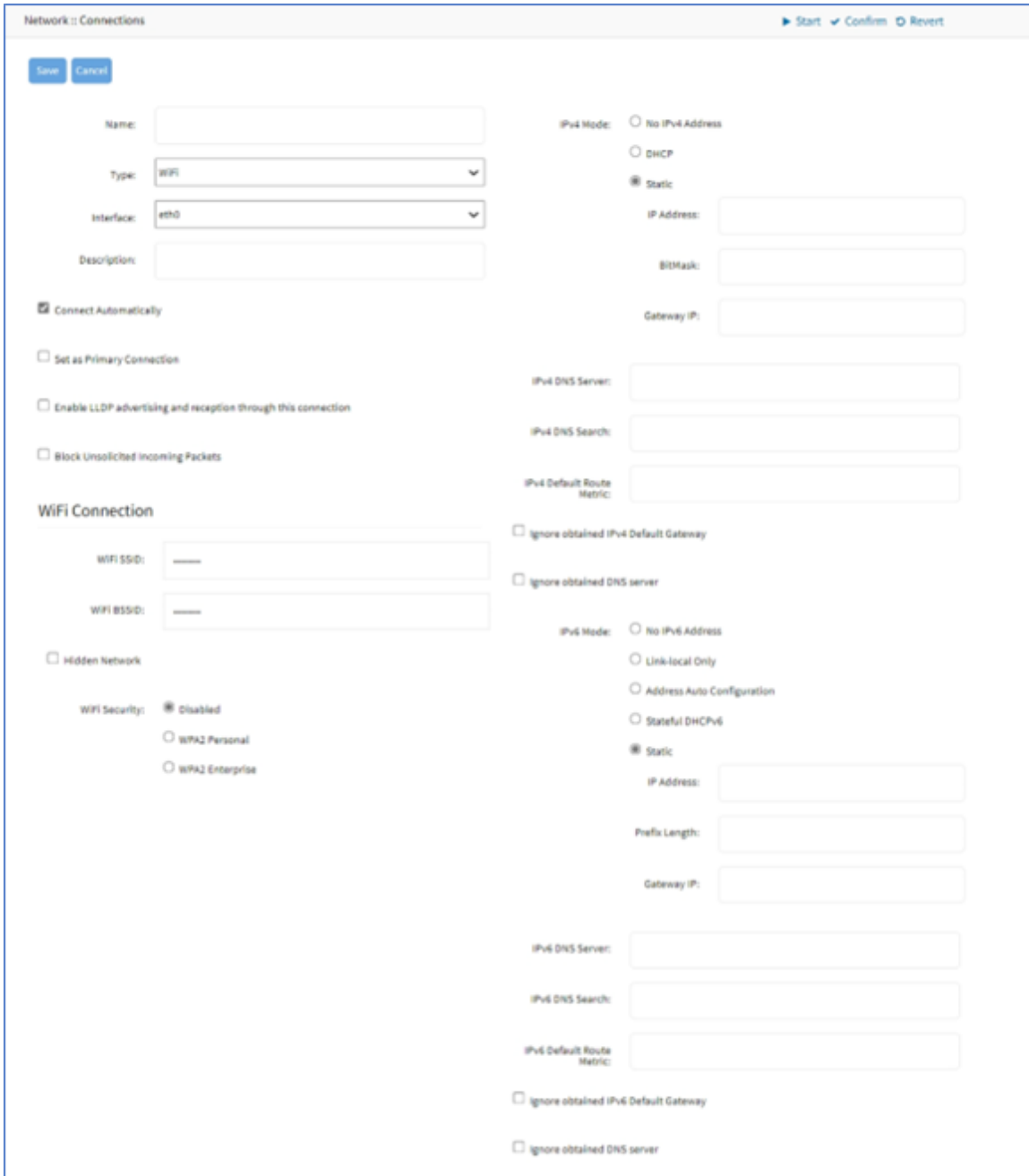

The screenshot shows the 'Network :: Connections' configuration window. The 'Type' dropdown is set to 'WiFi'. The 'Interface' dropdown is set to 'eth0'. The 'WiFi Connection' section is expanded, showing fields for 'WiFi SSID' and 'WiFi BSSID'. The 'WiFi Security' section is set to 'Disabled'. The 'IPv4 Mode' is set to 'Static', and the 'IPv6 Mode' is also set to 'Static'. The 'Connect Automatically' checkbox is checked. The 'Save' and 'Cancel' buttons are visible at the top left.

5. On **Interface** drop-down, select **wlan0**.
6. Enter a **Description**
7. In *WiFi Connection* menu
  - Enter **SSID**
  - Enter **BSSID**

8. On *WiFi Security* menu, select appropriate radio button.  
Enter Security settings (required for the selected connection)
9. Click **Save**.

# General Information

## User Interfaces

### WebUI Banner

This banner header provides links to major sections of the Nodegrid Manager. Several tools are also available.

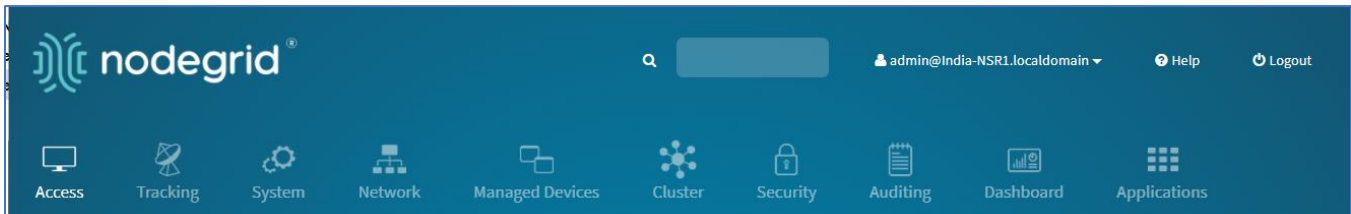

Each icon opens options to view and modify settings. Details on each section are available in the User Guide.

### Search Bar

The search bar provides advanced search capabilities to locate and view information. Boolean expressions are allowed. See Search Functionality for more details.

### Account drop-down options

The account name drop-down provides several options.

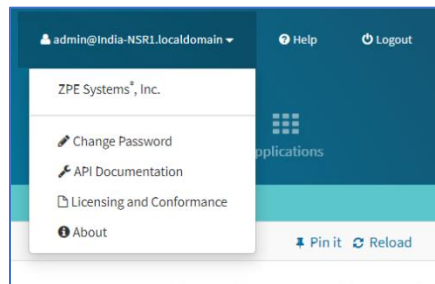

### Change Password

1. On the **Account Name** (upper right) drop-down, click **Change Password**.
2. On the *Change Password* dialog, enter the required fields:

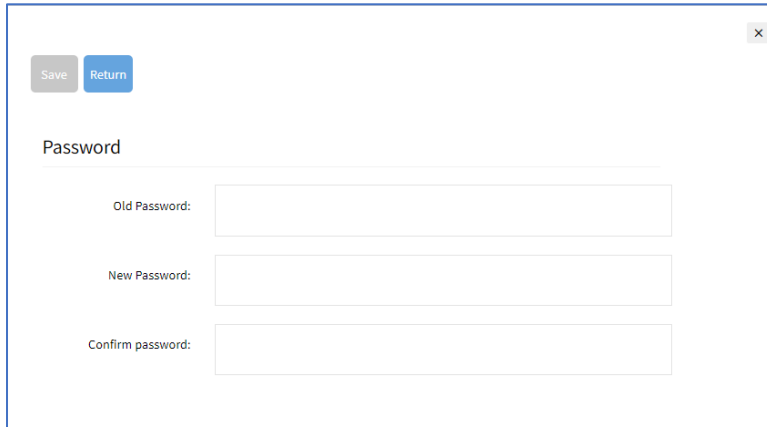

3. Enter **Old Password**.
4. Enter **New Password** and **Confirm Password**.
5. Click **Save**.

### API Documentation

This links to the Nodegrid API documentation.

### Licensing and Conformance

This opens the page with Nodegrid license and conformance details.

```

OPEN SOURCE LICENSES INFORMATION

This product includes copyrighted third-party software licensed under the terms of the
GNU General Public License, Apache License, BSD, MIT and other Open Source Licenses.

The complete set of third-party software and respective licenses are listed below:

PACKAGE                                                                                               LICENSE
=====
acl-locale-de (v2.2.53)                                       LGPL-2.1+ & GPL-2.0+
acl-locale-fr (v2.2.53)                                       LGPL-2.1+ & GPL-2.0+
acpid (v2.0.32)                                               GPL-2.0+
adwaita-icon-theme-symbolic (v3.34.3)                       LGPL-3.0 | CC-BY-SA-3.0
alsa-conf (v1.2.1.2)                                         LGPL-2.1 & GPL-2.0+
alsa-lib (v1.2.1.2)                                          LGPL-2.1 & GPL-2.0+
alsa-ucm-conf (v1.2.1.2)                                     BSD-3-Clause
android-tools-ext (v7.1.1_r22)                               Apache-2.0 & GPL-2.0 & BSD-2-Clause &
BSD-3-Clause
android-udev (vgit)                                         GPL-3.0
apache2 (v2.4.39)                                           Apache-2.0
apr (v1.7.0)                                                 Apache-2.0
apr-util (v1.6.1)                                           Apache-2.0
astarte-device-sdk-qt5 (v0.10)                               Apache-2.0
at-spi2-atk (v2.34.1)                                       LGPL-2.1+
at-spi2-core (v2.34.0)                                       LGPL-2.1+
at-spi2-core-locale-de (v2.34.0)                             LGPL-2.1+
at-spi2-core-locale-en-gb (v2.34.0)                         LGPL-2.1+
at-spi2-core-locale-fr (v2.34.0)                             LGPL-2.1+
at-spi2-core-locale-ja (v2.34.0)                             LGPL-2.1+
atk (v2.34.1)                                               GPL-2.0+ & LGPL-2.0+
atk-locale-de (v2.34.1)                                       GPL-2.0+ & LGPL-2.0+
atk-locale-en-gb (v2.34.1)                                   GPL-2.0+ & LGPL-2.0+

```

### About

This displays the *About* pop-up dialog with the device version and hardware details.









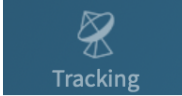
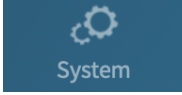

## Banner Section Icons

Each device’s Nodegrid Platform can be accessed from ZPE Cloud via WebUI. This provides full access to device configuration and management.

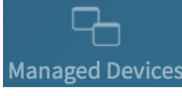
All modern browsers with HTML5 are supported, including mobile (phone/tablet) browsers. This includes Internet Explorer 11, Edge, Chrome, and Firefox.

## Device WebUI Section Icons

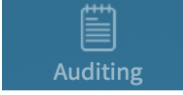
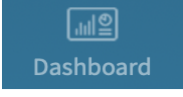
Menu	Item	Description
Access		Easy access for all device users. With appropriate permissions, users can start sessions, control power and review device logging details.
Tracking		Provides an overview of general statistics and system information, including system utilization and serial port statistics.
System		Administrators can perform general admin tasks (firmware updates, backups , restorations, licensing).
Network		Access and management of all network interfaces and features.
Managed Devices		Administrators can add, configure, and remove devices managed through the Nodegrid platform.

Menu	Item	Description
Cluster		Administrators can configure Nodegrid Cluster feature.
Security		User access configuration options and general security settings.
Auditing		Administrators can configure auditing levels and locations, and some global logging settings.
Dashboard		Users and administrators can create and view dashboards and reports.
Applications		Only visible with a valid Virtualization license. Administrators can manage and control NFVs and Docker applications.

## Configuration Updates

In all sections (excluding *Access* and *Tracking*), configuration updates can be implemented with these buttons (located at upper right area on each page).

▶ Start ✓ Confirm ↺ Revert ↻ Reload

In this section, configuration changes can be initiated with these actions.

**Start** - initiates 30 seconds time window to apply the specific settings.

**Confirm** – setting changes are confirmed and permanently applied (if clicked before 30 second window)

**NOTE:** If confirm is not clicked before 30 seconds, settings will be reverted back automatically

**Revert** – changes are reverted and are not applied.

**Reload** – reloads settings to refresh the displayed content.

## CLI Interface

The Nodegrid Platform can be accessed through a CLI interface, by connecting to the platform with a SSH client or through its console port. The interface can manage and configure the device, including access to console target sessions. CLI structure generally follows the WebUI.

## CLI Folders

Folder	Description
/access	Access for all users to managed devices. Users with appropriate permissions can start sessions, control power, and review device logging details.
/system	Provides access to the combined functions of the Tracking and System menu (accessed with WebUI). Tracking features include an overview of general statistics and system information (system utilization, serial port status, etc.). Administrators can perform general admin tasks on the Nodegrid Platform (i.e., firmware updates, backups, restorations, and licensing).
/settings	Provides access to the system, security, auditing, and managed device settings, and configuration options.

The CLI provides many commands and options. General usage includes several basic commands.

## CLI Commands

CLI Command	Description
TAB TAB	Lists all available commands, settings, or options currently available.
cd cd - (cd<space><dash>	Returns user to root/home directory. Moves location up on level (i.e., if at <i>/settings/authentication</i> , enter <b>cd -</b> to go to <i>/settings</i> folder).
ls	Lists the current folder structure.
show	Displays current settings in a tabular view.
set	Initiates changes and settings with “set option=value”. Multiple settings can be combined in sequence of option=value pairs (i.e., set option1=value1 option2=value2). Regular expressions are supported.
commit	Commits changes to configurations. A “show” command can display whether previous line entries were saved. If not saved, enter commit. A “+” in front of the command prompt, [i.e., +admin@nodegrid /]# is shown only when editing an entry or configuration. To add new entries, the + indicator is not displayed – and “commit” is required.
cancel or revert	Either command can restore a setting from the most recent “commit” command.

## Examples

```
[admin@nodegrid /]# ls
access/
system/
settings/
[admin@nodegrid /]# show
[admin@nodegrid /]# show /access/
name                status
```

```

=====
Device_Console_Serial Connected
[admin@nodegrid /]# set settings/devices/ttyS2/access/ mode=on-demand
[+admin@nodegrid /]# set settings/devices/ttyS2/access/ rs-
232_signal_for_device_state_detection=
CTS DCD None
[+admin@nodegrid /]# set settings/devices/ttyS2/access/ rs-
232_signal_for_device_state_detection=DCD enable_hostname_detection=yes
[+admin@nodegrid /]# commit
[admin@nodegrid /]#
    
```

## Shell Access

The Nodegrid Platform has direct access to the operating system’s shell. By default, this is only available to the root user (directly) and admin user (from CLI). Direct shell access can be granted to users of specific groups (useful for system automation processes which require direct shell access. Authorization for users is provided with SSH key authorization.

Access should be limited based on shell access requirements. This requires careful consideration and caution. Changes made through shell access can have a negative impact.



## Access to Devices

This provides an overview of all available devices (Search is available). Users can connect to managed devices and review current device status. User permissions and current state of Nodegrid Cluster nodes determine which devices are displayed.

## Device Sessions

When a user logs into the WebUI, the first page is the Access section. This is overview of all available user-accessible targets. Each device current connection status and available connection types are shown.

**Device Sessions**

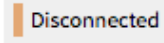
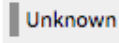
State	Indicator color	Icon	Description
Connected	Green		Nodegrid can successfully connect to the device and it is available for sessions
In-Use	Blue		The Device is currently in use
Disconnected	Orange		Nodegrid could not successfully connect to the device and it is not available for sessions
Unknown	Grey		The connection status is unknown. This is the default state for devices with the connection mode On-Demand or for new devices for which the discovery process is not completed.

Device sessions can be directly started from this location.

### WebUI View

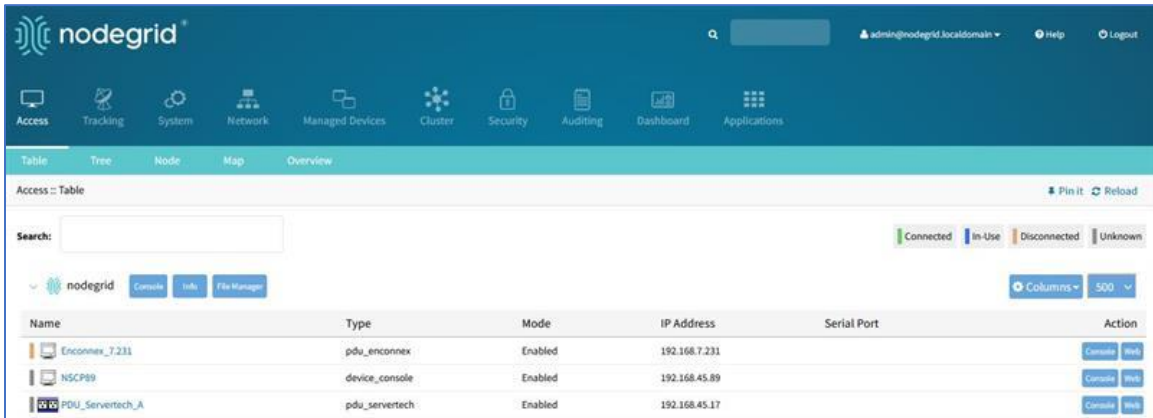

### Console (CLI) View



Click **Console** to display a new target session window.



Buttons at lower center can further control the session and device. Available options depend on connection type and device configuration.

#### Session Options

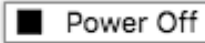
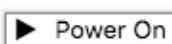
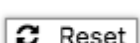
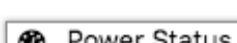
Options	Description
Info	Displays current device details.
Full Screen	Expand the window to use the full monitor screen. The session window does not expand beyond its maximum size.

Options	Description
	Performs a power off on the device through a connected Rack PDU or IPMI device.
	Performs a power on for the device through a connected Rack PDU or IPMI device.
	Initiates a power cycle on the device through a connected Rack PDU or IPMI device.
	Display device's current power status (as returned by a connected Rack PDU or IPMI device).
	Closes the active session.
	Expands or minimizes the command line options at the window's lower center.

Close the CLI window to end the device session.

### Copy & Paste Functionality

**NOTE:** TTYD terminal copy and paste is not currently supported within Windows and Linux.

Nodegrid supports **Copy & Paste** of text between the HTML5 graphical device session window and the desktop environment. Some OS may require a different key combination.

Windows and Linux user – Ctrl+Ins to copy highlighted text and Shift+Ins to paste.

Mac users - Cmd+C to copy, and Cmd+V to paste.

Highlight the text and right-click to open the menu – or use the shortcuts.

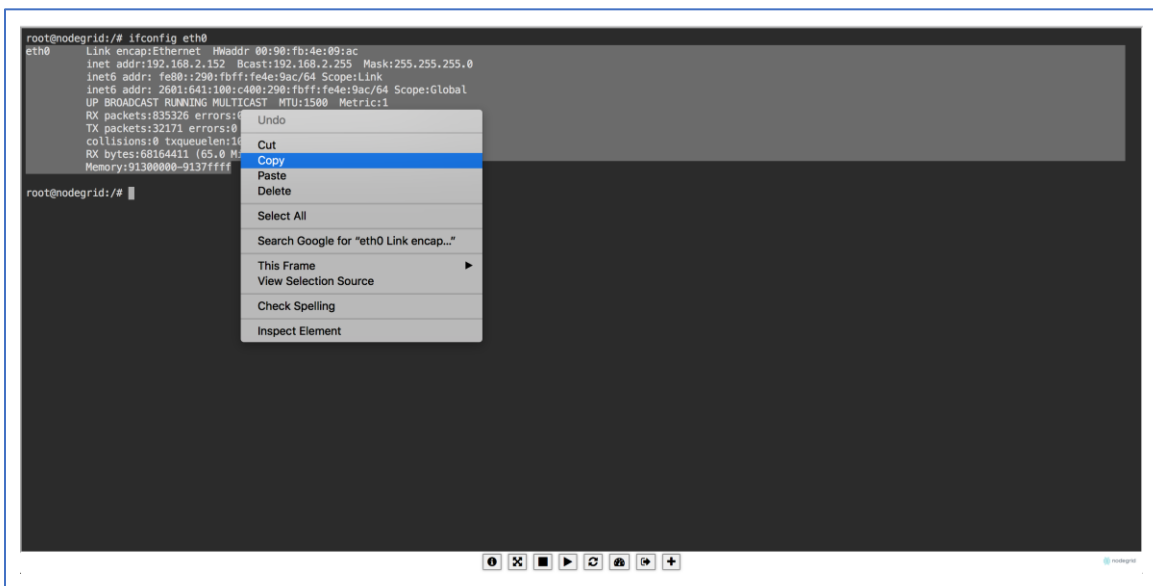

## CLI Device Sessions

A user can directly go to this directory with `cd /access`.

### View currently available targets

`show`.

Example:

```
[admin@nodegrid access]# show
name                status
=====
Device_Console_SSH  Connected
Device_Console_Serial InUse
IPMI                 Connected
RPDU                 Connected
usbS2                Connected
```

### Start a device session

`connect <target name>`

Example:

```
[admin@nodegrid access]# connect Device_Console_Serial
[Enter '^Ec?' for help]
[Enter '^Ec.' to cli ]

login:
```

**NOTE:** Only console sessions or sessions which provide a text-based interface can be started from the CLI.

With an established connection, use the escape sequence `^Ec` or `^O` to further control the session.

**NOTE:** Escape sequences can be changed in Device Settings.

### Session Options

Option	Escape sequence	Description
.	^Ec.	Disconnect the current session.
g	^Ecg	Display current user group information.
l	^Ecl	Send break signal (defined in Device Settings).
w	^Ecw	Display currently connected users.

Option	Escape sequence	Description
<cr>	^Ec<cr>	Send ignore/abort command signal.
k	^Eck	Serial port (speed data bits parity stop bits flow).
b	^Ecb	Send a broadcast message. Type message after the escape sequence.
i	^Eci	Display current serial port information.
s	^Ecs	Change current session to read-only mode.
a	^Eca	Change current session to read-write mode.
f	^Ecf	Force current session to read-write mode.
z	^Ecz	Disconnect a specific connected user session.
?	^Ec?	Print this message.

Power Control options are available on targets connected to a managed Rack PDU or provided power control through IMPI. The power menu can be displayed with ^O.

```

Power Menu - Device_Console_Serial
Options:
1. Exit
2. Status
3. On
4. Off
5. Cycle

Enter option:
  
```

## Search Functionality

The Nodegrid Manager provides advanced search capabilities to locate and view device information.

### Device Search

In the WebUI, this is available on all Device views and can filter device lists based on search criteria. On the CLI, the search command is available in the access folder.

**NOTE:** The function is available on stand-alone units and units in a Cluster configuration. All changes to device information and newly added device properties are automatically updated in the System as a background function.



### Search Field Options

Field	Description
[search string]	A search string that represents part of or a complete string.
AND	Combines multiple search strings with an Boolean AND.
OR	Combines multiple search strings with a Boolean OR. Default search behavior for more than one search string.
NOT	Targets matching the search string with Boolean NOT are excluded from the returns.
[field name]	Limits the search results to a specific Field Name.

**NOTE:** The Boolean keywords AND, OR and NOT are case-sensitive. Lower-case is entered (and, or, not) is included as part of the search string.

#### Examples of standard and custom field data searches

This includes groups (such as “admin” group), IP addresses or a specific device.

#### Example with AND “PDU AND IPMI”

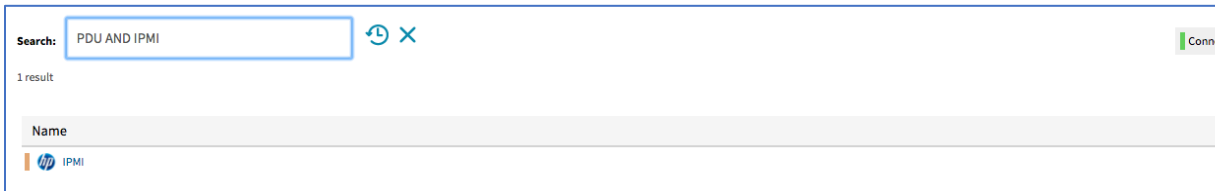

```
[admin@nodegrid search]# search "PDU AND IPMI"

search: PDU AND IPMI
results: 1 result
page: 1 of 1

[admin@nodegrid search]# show
name status action
==== =====
IPMI -
```

#### Example with OR "PDU OR IPMI"

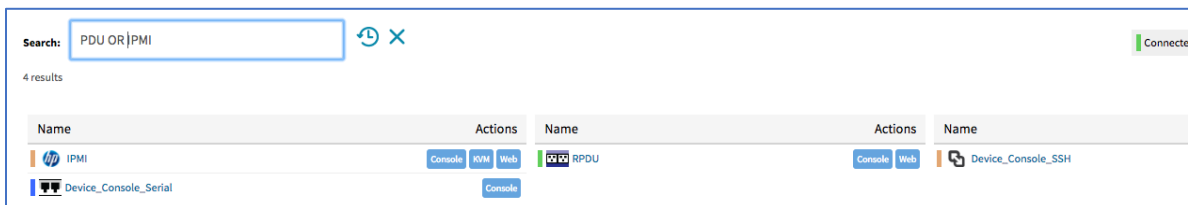

```
[admin@nodegrid access]# search "PDU OR IPMI"
```

```
search: PDU OR IPMI
results: 4 results
page: 1 of 1
```

```
[admin@nodegrid search]# show
```

name	status	action
=====	=====	=====
IPMI	-	
RPDU	-	
Device_Console_SSH	-	
Device_Console_Serial	-	

### Example with "PDU IPMI"

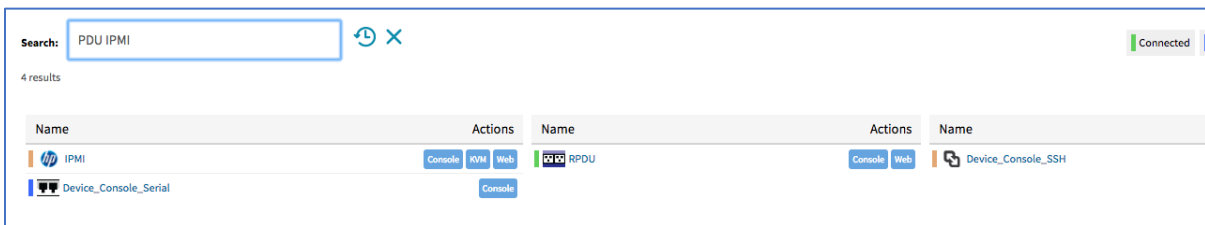

Search: PDU IPMI Refresh Close Connected

4 results

Name	Actions	Name	Actions	Name
IPMI	<a href="#">Console</a> <a href="#">KVM</a> <a href="#">Web</a>	RPDU	<a href="#">Console</a> <a href="#">Web</a>	Device_Console_SSH
Device_Console_Serial	<a href="#">Console</a>			

```
[admin@nodegrid access]# search "PDU IPMI"
```

```
search: PDU IPMI
results: 4 results
page: 1 of 1
```

```
[admin@nodegrid search]# show
```

name	status	action
=====	=====	=====
IPMI	-	
RPDU	-	
Device_Console_SSH	-	
Device_Console_Serial	-	

### Example with NOT "PDU AND NOT IPMI"

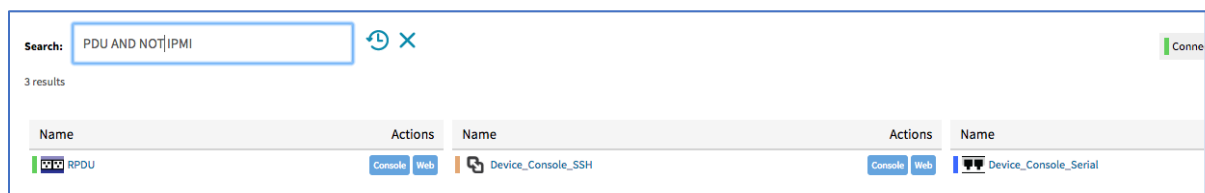

Search: PDU AND NOT IPMI Refresh Close Conne

3 results

Name	Actions	Name	Actions	Name
RPDU	<a href="#">Console</a> <a href="#">Web</a>	Device_Console_SSH	<a href="#">Console</a> <a href="#">Web</a>	Device_Console_Serial

```
[admin@nodegrid search]# search "PDU AND NOT IPMI"
```

```

search: PDU AND NOT IPMI
results: 3 results
page: 1 of 1

[admin@nodegrid search]# show
  name                status  action
  =====  =====  =====
RPDU
Device_Console_SSH  -
Device_Console_Serial  -
  
```

**Example with Field Name "name:PDU"**

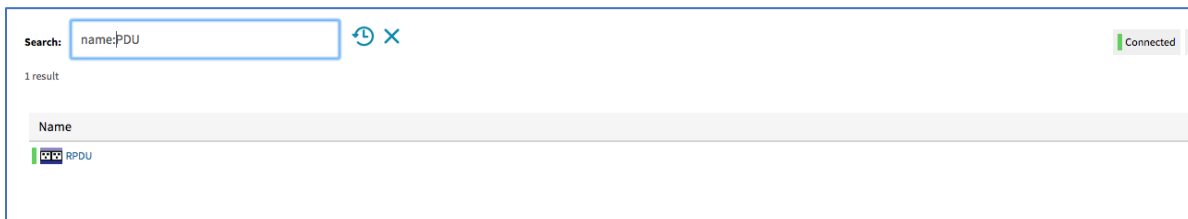

```

[admin@nodegrid search]# search "name:PDU"

search: name:PDU
results: 1 result
page: 1 of 1

[admin@nodegrid search]# show
  name  status  action
  ====  =====  =====
RPDU   -
  
```

**Global Search**

The WebUI has a Global Search field located at the top, next to current user information and log out. Global Search works in the same as Device Search and supports the same keywords. This is available at the top of all pages.

**Access Section**

Each device on the Nodegrid platform has embedded device information. This information is visible to users and is fully searchable. The stored information includes discovered values and those set during device configuration. An administrator can associate additional device information.



The WebUI offers multiple ways to view and access devices. By default, all users have access to the Table view. Other views are also available and improve the accessibility or visualization of the current device status.

Each user can change the default view after login. To change the default view, display the preferred view and click **Pin It** (upper right).

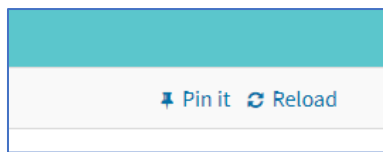

## Table tab

This provides easy access to all devices with current status conditions. Any connected devices to a device are shown on the Cluster page.

**NOTE:** When attempting to access an unlicensed or expired license device, an error message displays. Contact ZPE to update the license.

In the table, the *Action* column shows buttons to access that device. Type of button depends on device: **Console, SSH, Telnet, KVM, MKS.**

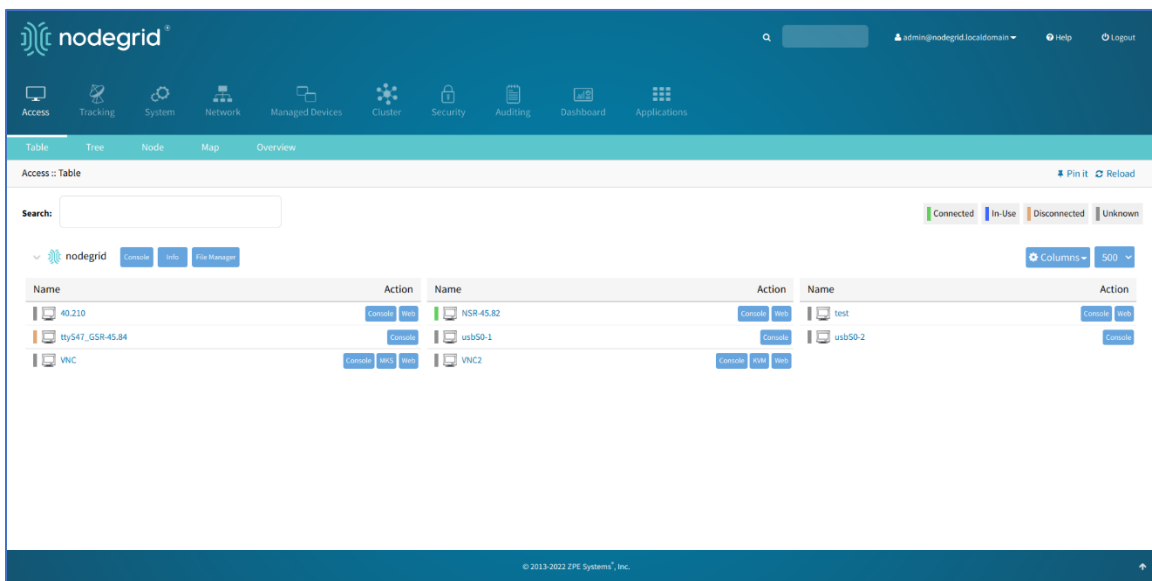

Click on a device to provide the full range of access.

Description	Value
Name	NSR-test
Alias	DeviceAlias1
Status	Unknown
Type	device_console
Mode	Enabled
Licensed	Yes
Nodegrid Host	nodegrid.localdomain
Groups	default, admin, user

## Function Descriptions

These are additional functions on the page.

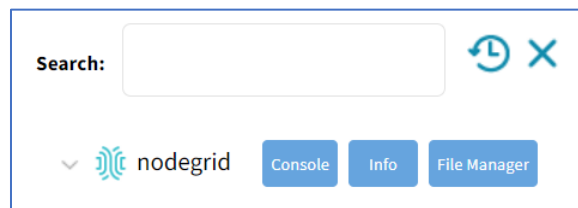

- **Search** – entry returns list of matches.

These entries are accepted:

[search string] (string to represent part of or a complete string)

Boolean (AND, OR, NOT – caps only)

[field name] (limits results to a specific Field Name).

**Clock** icon (shows a history of past searches)

**"X"** (clears the search field)

- **Arrow** (show/hide table – click down arrow to hide table, click up arrow to show table)

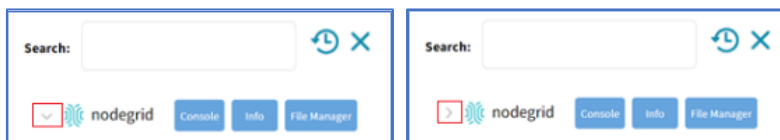

- **Console** (display CLI window)

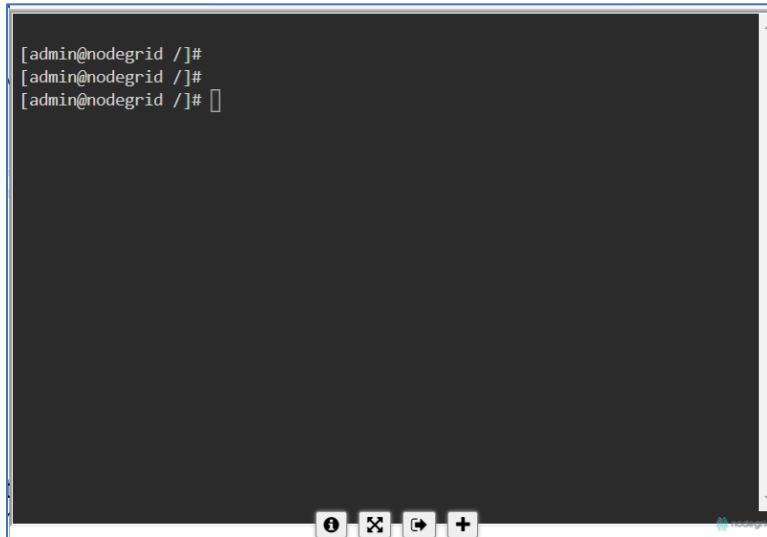

- **Info** (pop-up dialog provides device-specific details)

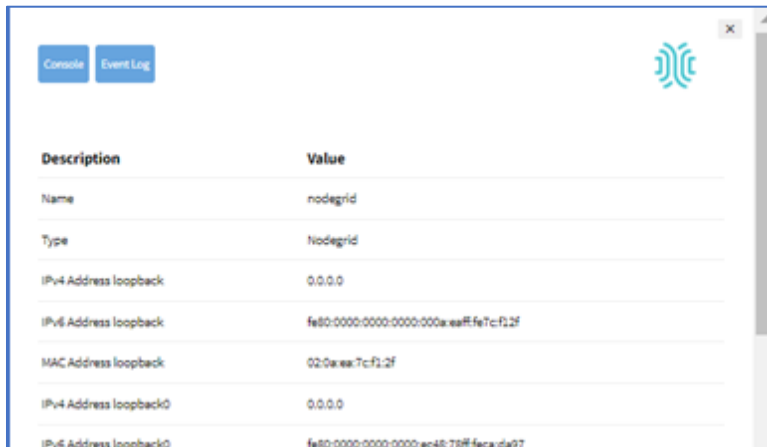

Description	Value
Name	nodegrid
Type	Nodegrid
IPv4 Address loopback	0.0.0.0
IPv6 Address loopback	fe80:0000:0000:0000::ea:ea#fe7c:f1:2f
MAC Address loopback	02:0a:ea:7c:f1:2f
IPv4 Address loopback0	0.0.0.0
IPv6 Address loopback0	fe80:0000:0000:0000::e48:70#f6ca:da07

*Pop-up dialog buttons:*

**Console** button – opens the Console (CLI) window (see above).

**Event Log** button – displays the raw log details.

```

Page 1 - 10/05/2021 18:22:55

<2021-10-05T13:21:03Z> Event ID 103: Software upgrade completed, Status: 1, New software version: 5.1.2.
<2021-10-05T13:21:03Z> Event ID 101: The system has started.
<2021-10-05T13:21:04Z> Event ID 140: Connection up, Connection: ETH0, Interface: eth0, Type: ethernet, IP A
address: 192.168.7.43/24.
<2021-10-05T13:21:55Z> Event ID 520: A Extended Storage started.
<2021-10-05T15:58:05Z> Event ID 202: User authentication failed, User: admin@192.168.14.46.
<2021-10-05T15:58:28Z> Event ID 202: User authentication failed, User: admin@192.168.14.46.
<2021-10-05T16:29:28Z> Event ID 202: User authentication failed, User: admin@192.168.14.46.
<2021-10-05T16:29:48Z> Event ID 202: User authentication failed, User: admin@192.168.14.46.
<2021-10-05T17:07:39Z> Event ID 202: User authentication failed, User: admin@192.168.14.46.
<2021-10-05T17:07:57Z> Event ID 202: User authentication failed, User: admin@192.168.14.46.
<2021-10-05T17:09:46Z> Event ID 202: User authentication failed, User: admin@192.168.14.39.
<2021-10-05T17:09:56Z> Event ID 202: User authentication failed, User: admin@192.168.14.39.
<2021-10-05T17:10:17Z> Event ID 200: A user logged into the system, User: admin@192.168.14.39, Session type
: HTTPS, Authentication Method: Local.
<2021-10-05T17:11:30Z> Event ID 200: A user logged into the system, User: admin@192.168.14.46, Session type
: HTTPS, Authentication Method: Local.
<2021-10-05T17:11:45Z> Event ID 201: A user logged out of the system, User: admin, Session type: unknown.
<2021-10-05T17:16:25Z> Event ID 201: A user logged out of the system, User: admin@192.168.14.39, Session ty
pe: HTTPS.
<2021-10-05T17:16:25Z> Event ID 201: A user logged out of the system, User: admin@192.168.14.46, Session ty
pe: HTTPS.
<2021-10-05T17:17:10Z> Event ID 202: User authentication failed, User: admin@192.168.14.39.
<2021-10-05T17:17:19Z> Event ID 200: A user logged into the system, User: admin@192.168.14.39, Session type
: HTTPS, Authentication Method: Local.
<2021-10-05T17:19:45Z> Event ID 200: A user logged into the system, User: admin@192.168.14.21, Session type
: HTTPS, Authentication Method: Local.
<2021-10-05T17:23:08Z> Event ID 102: Software upgrade started, User: root, Current version: 5.1.2, New vers
ion: 5.2.3.
<2021-10-05T17:30:27Z> Event ID 140: Connection up, Connection: ETH0, Interface: eth0, Type: ethernet, IP A

```

• **File Manager** (display folder/file structure)

Type	Name	Size	Time
Folder	admin_group	4.00 KB	3/9/2018 4:34:56 AM
Folder	admin_home	4.00 KB	3/9/2018 4:34:56 AM
Folder	dataalog	4.00 KB	9/29/2021 11:04:19 AM
Folder	datastore	4.00 KB	3/9/2018 4:34:56 AM
Folder	eventlog	4.00 KB	9/30/2021 6:40:55 AM
Folder	nodegrid_ap	4.00 KB	3/9/2018 4:34:56 AM
Folder	remote_file_system	4.00 KB	3/9/2018 4:34:56 AM
Folder	sed	4.00 KB	3/9/2018 4:34:56 AM
Folder	software	4.00 KB	9/30/2021 6:39:32 AM

• **Page Quantity** button – on the drop-down (100, 250, 500, 750, 1000) to select the number of items to display on the page.

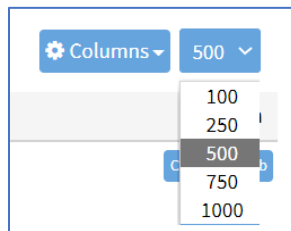

**Display Table Columns**

*WebUI Procedure*

Details on each device can be viewed by selecting columns.

1. Go to *Access :: Table*.
2. On the right side, click **Columns** (displays a drop-down dialog of available table columns).

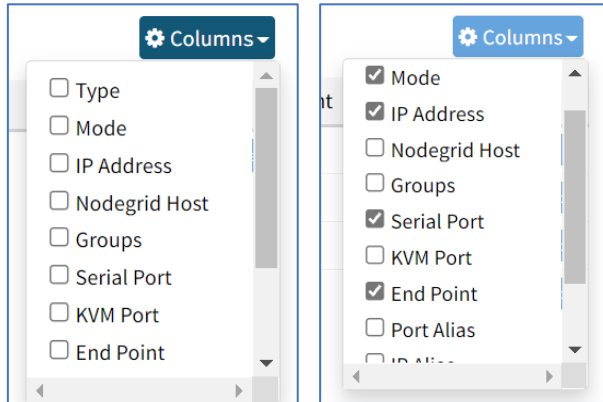

3. As columns are selected, they are displayed in the table.

Peers Settings Management

Cluster :: Peers Reload

Search:  Refresh Close

Connected In-Use Disconnected Unknown

nodegrid Console Info File Manager Columns

Name	Type	Mode	IP Address	Serial Port	End Point	Action
console_server_acs	console_server_acs	Enabled			appliance	<span>Console</span> <span>Web</span>
ttyS13	local_serial	Enabled		ttyS13		<span>Console</span>
usbS0-1	usb_serialB	Enabled		usbS0-1		<span>Console</span>
usbS0-3	usb_serialB	On-demand		usbS0-3		<span>Console</span>

## View Device Details

Click on a device to provide the full range of access.

Console SSH Telnet KVM WEB Close

Description	Value
Name	NSR-test
Alias	DeviceAlias1
Status	Unknown
Type	device_console
Mode	Enabled
Licensed	Yes
Nodegrid Host	nodegrid.localdomain
Groups	default, admin, user

This is an example of a Switch device:



Console
WEB



Port Status

Port	Name	Type	Admin Status	Link Status
1	Port_1	unknown	unknown	Unknown
2	Port_2	unknown	unknown	Unknown
3	Port_3	unknown	unknown	Unknown
4	Port_4	unknown	unknown	Unknown
5	Port_5	unknown	unknown	Unknown

Description	Value
Name	edgecore_switch
Alias	DeviceAlias52
Status	Unknown
Type	switch_edgecore
Mode	Enabled
Licensed	Yes
IP Address	192.168.2.10
MAC Address	F8:8E:A1:22:B1:2C
Nodegrid Host	nodegrid.localdomain
Groups	admin

## Manage Power

### View Device Power Details

#### WebUI Procedure

1. Go to *Access :: Table*.
2. In the **Name** column, locate and click the name (displayed dialog details change according to the type).

Description	Value
Name	ttyS13
Local Serial Port	ttyS13
Baud Rate	9600
Status	Disconnected
Type	local_serial
Mode	Enabled
Licensed	Yes
Nodegrid Host	nodegrid.localdomain
Telnet Port Alias	7013
Groups	admin

### CLI Procedure

Example:

```
[admin@nodegrid /]# cd /access/
[admin@nodegrid access]# show Device_Console_Serial/
name: Device_Console_Serial
status: Connected
```

## Set Device USB Power Option

### WebUI Procedure

1. To confirm the USB card supports USB Passthrough, go to *System :: Slots. Supported cards* . Check the *Add-ons* column for the entry: **Power Control**.
2. Go to *Access :: Table*.
3. Locate and click the device name.
4. On the pop-up dialog, select a power option.

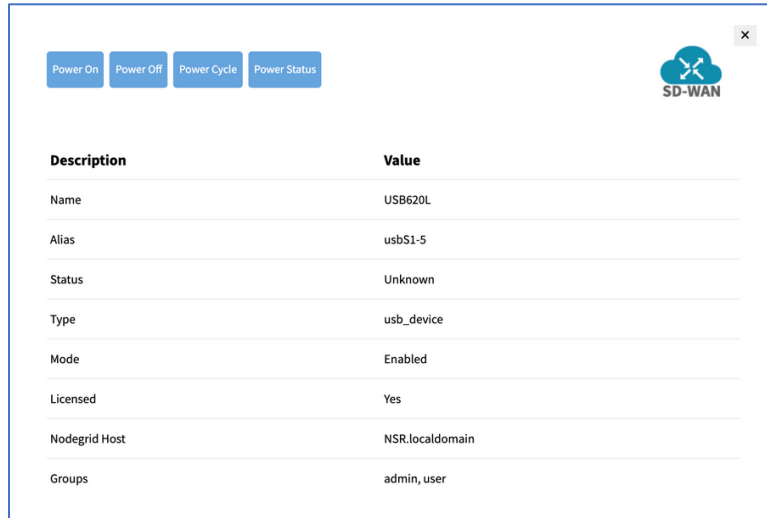

**Power On** (turns power on)

**Power Off** (turns power off)

**Power Cycle** (cycles power on and off)

**Power Status** (current status)

## Tree tab

This displays the physical hierarchies of the Nodegrid setup. Start connections can be applied to each device. Devices can be found based on location (i.e., Nodegrid name, city name, data center name, row and rack, and others). Filters can be applied based on location and device types. Select from the expanded *View* column branches: *Devices*, *Appliances*, *Groups*.



## View Column Branches

There are three trees in the View columns: **Devices**, **Appliances**, **Groups**. Details can be observed by clicking the ">".



## Expand Individual Tree

### WebUI Procedure

This example uses *Devices*.

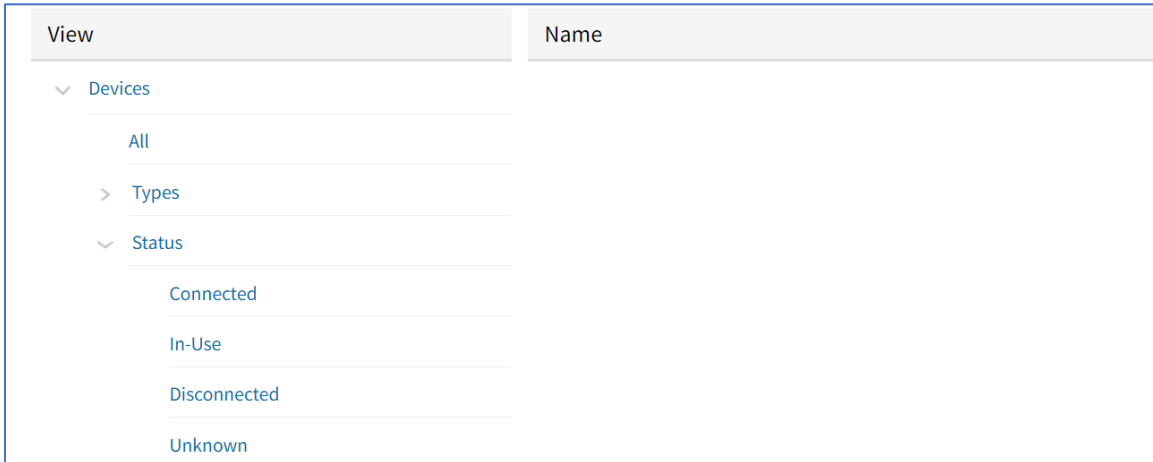
1. Click the right  icon to display the next branch level.



2. If further branch levels are available, click the right arrow  icon to expand the branch.
3. To contract the branch, click the down arrow  icon.
4. To see every item in the tree, click on **All**. Click on other items to see associated names (some clicked items may not have names).
5. Click on a name to display a pop-up dialog of details.

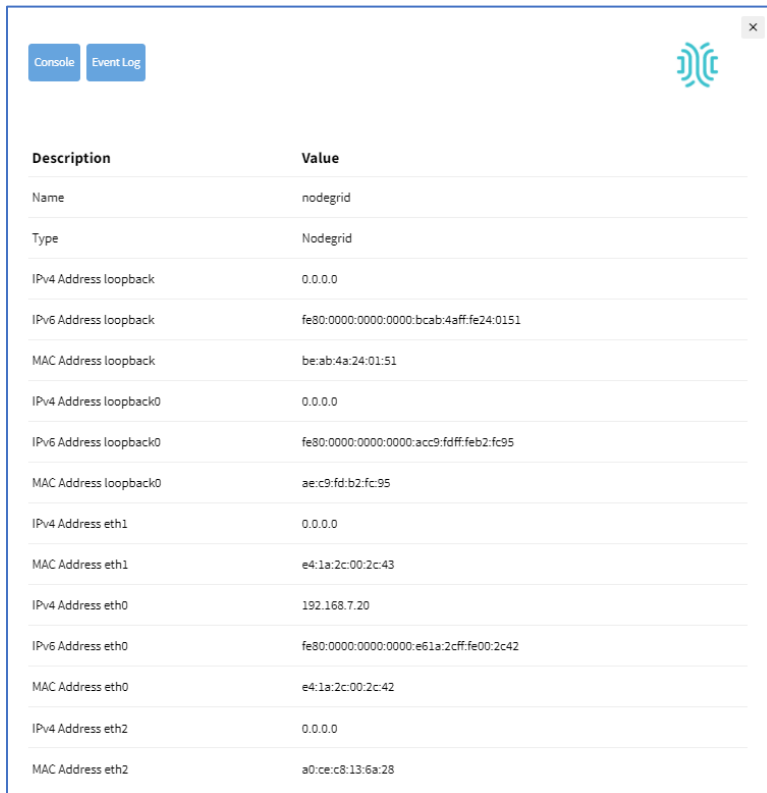

Description	Value
Name	nodegrid
Type	Nodegrid
IPv4 Address loopback	0.0.0.0
IPv6 Address loopback	fe80:0000:0000:0000:bcab:4aff:fe24:0151
MAC Address loopback	be:ab:4a:24:01:51
IPv4 Address loopback0	0.0.0.0
IPv6 Address loopback0	fe80:0000:0000:0000:acc9:fdff:feb2:fc95
MAC Address loopback0	ae:c9:fd:b2:fc:95
IPv4 Address eth1	0.0.0.0
MAC Address eth1	e4:1a:2c:00:2c:43
IPv4 Address eth0	192.168.7.20
IPv6 Address eth0	fe80:0000:0000:0000:e61a:2cff:fe00:2c42
MAC Address eth0	e4:1a:2c:00:2c:42
IPv4 Address eth2	0.0.0.0
MAC Address eth2	a0:ce:c8:13:6a:28

## Node tab

This arranges all devices around connected Nodegrid units. It provides a complete overview of all targets and Nodegrid units in a Cluster.

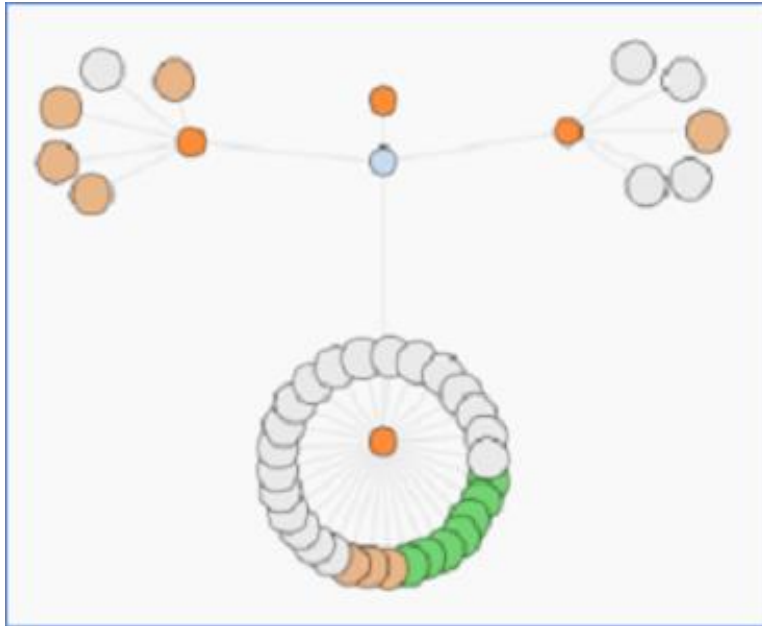

Click on a node to display a pop-up dialog of details.

Console
Event Log
x



Description	Value
Name	nodegrid
Type	Nodegrid
IPv4 Address loopback	0.0.0.0
IPv6 Address loopback	fe80:0000:0000:0000:bcab:4aff:fe24:0151
MAC Address loopback	be:ab:4a:24:01:51
IPv4 Address loopback0	0.0.0.0
IPv6 Address loopback0	fe80:0000:0000:0000:acc9:fdff:feb2:fc95
MAC Address loopback0	ae:c9:fd:b2:fc:95
IPv4 Address eth1	0.0.0.0
MAC Address eth1	e4:1a:2c:00:2c:43
IPv4 Address eth0	192.168.7.20
IPv6 Address eth0	fe80:0000:0000:0000:e61a:2cff:fe00:2c42
MAC Address eth0	e4:1a:2c:00:2c:42
IPv4 Address eth2	0.0.0.0
MAC Address eth2	a0:ce:c8:13:6a:28

## Map tab

This shows device status on a global-based map. This provides an overview of all targets and Nodegrid units in a Cluster. Precise device location details are included down to a building level. Click on a marker to display information and connections.

**Global View**

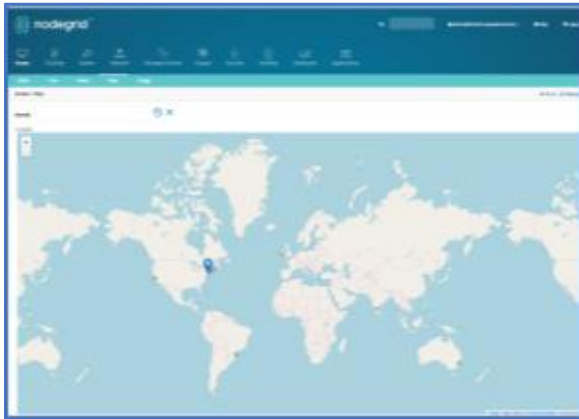

**Zoomed in Street View**

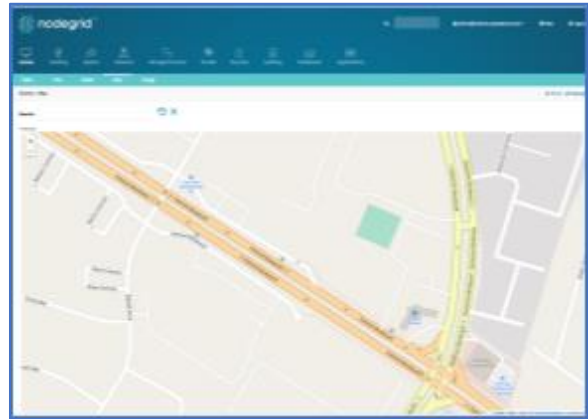

To move the map position, use click and drag.

## Overview tab

This tab provides information on the Nodegrid device.

If the device's System Profile is configured as Gateway Profile, Access :: Overview is the default WebUI page. For devices with Out of Band Profile, the user can use the **Pin It** feature to designate Access :: Overview as the default page.

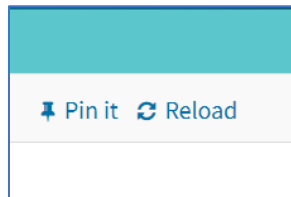

Click the **Widgets** button to configure the display. Select/unselect checkboxes as needed. The order of the checkboxes can be moved (click on a checkbox item, drag and drop inside the widget). This modifies the display of the Overview page.

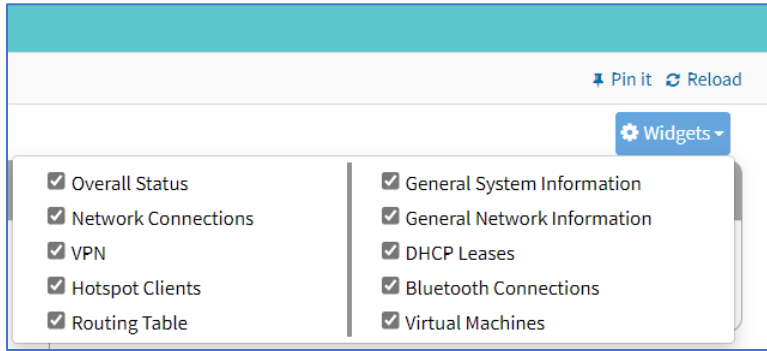

Review details, as needed.

Table Tree Node Map Overview

Access: Overview Pin It Reload

Widgets -

### Overall Status

**Connections**  
1 up of 7

**DHCP Leases**  
0

**ZPE Cloud**  
Disconnected

### General System Information

Software	Licenses	Uptime
v5.6.1 (May 16 2022 - 14:57:00)	1051	0 days, 0 hours, 44 minutes

### General Network Information

Hostname	Domain Name	DNS Server
nodegrid	localdomain	192.168.2.205 75.75.75.75 75.75.76.76
DNS Search	Fallover	
zpesystems.com	Disabled	

### Network Connections

Name	Status	Type	Interface	IPv4 Address	IPv6 Address
ETH0	Connected	Ethernet	eth0	192.168.7.20/24	fe80::e61a:2cff:fe00:2c42
ETH1	Not Active	Ethernet	eth1		
LAN0	Not Active	Ethernet	lan0		
LAN1	Not Active	Ethernet	lan1		
LAN2	Not Active	Ethernet	lan2		
LAN3	Not Active	Ethernet	lan3		
WAN0	Not Active	Ethernet	wan0		
WAN1	Not Active				
hotspot	Not Active				

### VPN

Name	Type	Status

### Hotspot Clients

Name	MAC Address	IP Address	Client ID	Lease Renewal

### Routing Table

Destination	Gateway	Metric	Interface	From	Table
0.0.0.0/0	192.168.7.1	0	eth0	192.168.7.20	eth0
0.0.0.0/0	192.168.7.1	90	eth0	all	main
192.168.7.0/24	-	0	eth0	192.168.7.20	eth0
192.168.7.0/24	-	90	eth0	192.168.7.20	eth0
192.168.7.0/24	-	90	eth0	all	main
192.168.7.20	-	0	eth0	192.168.7.20	eth0
fe80::/64	-	1024	eth0	fe80::e61a:2cff:fe00:2c42	eth0
fe80::/64	-	256	loopback	all	main
fe80::/64	-	256	loopback0	all	main
fe80::/64	-	90	eth0	fe80::e61a:2cff:fe00:2c42	eth0
fe80::/64	-	90	eth0	all	main

### Bluetooth Connections

Display name	Address	Connected	Network

### Virtual Machines

Name	Type	Status	Licensed



## Image tab

The configuration requires Professional Services implementation. Contact Customer Support at support@zpesystem.com for additional information.

If available, displays a custom view of Nodegrid units and devices with associated information.

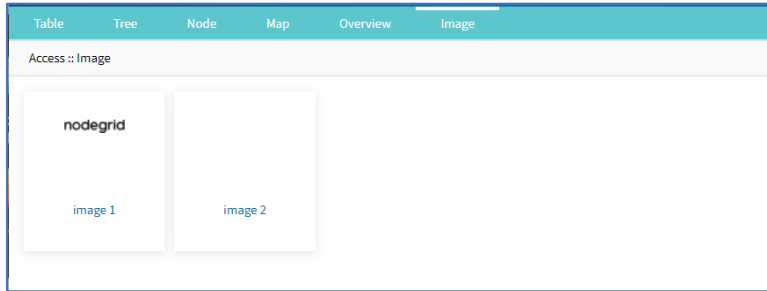

## Tracking Section

This provides information about the System and connected devices. This includes Open Sessions, Event List, Routing Table, System Usage, Discovery Logs, LLDP, and Serial Statistics.

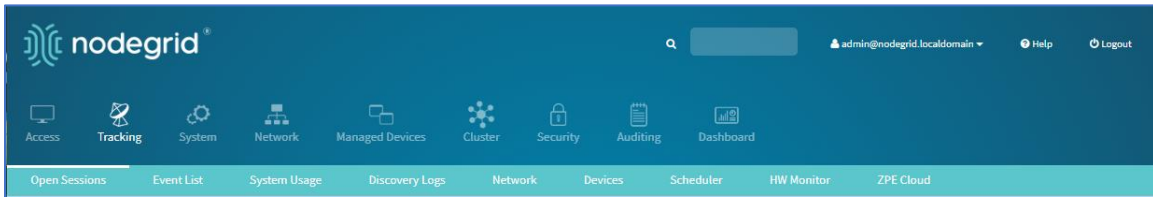

## Open Sessions tab

This provides an overview of connected users and devices sessions.

### Sessions Table sub-tab

This lists all users actively connected to the system, where they are connected from, and the time period.

Sessions Table		Devices Table					
Tracking :: Open Sessions :: Sessions Table							<a href="#">Reload</a>
<a href="#">Terminate</a>							Total Sessions: 4
<input type="checkbox"/>	User	Mode	Source IP	Type	Device Name	Ref	Session Start
<input type="checkbox"/>	admin	HTTPS	192.168.1.1	WEB		296	Mon May 16 19:24:07 2022
<input type="checkbox"/>	admin	HTTPS	192.168.14.62	WEB		9170	Tue May 17 13:43:57 2022
<input type="checkbox"/>	admin	HTTPS	192.168.14.50	WEB		10415	Tue May 17 16:17:19 2022
<input type="checkbox"/>	admin	HTTPS	192.168.14.62	WEB		10447	Tue May 17 16:19:30 2022

## Terminate Session

### WebUI Procedure

1. Go to *Tracking :: Open Sessions :: Sessions Table*.
2. In *User* column, locate session and select checkbox.

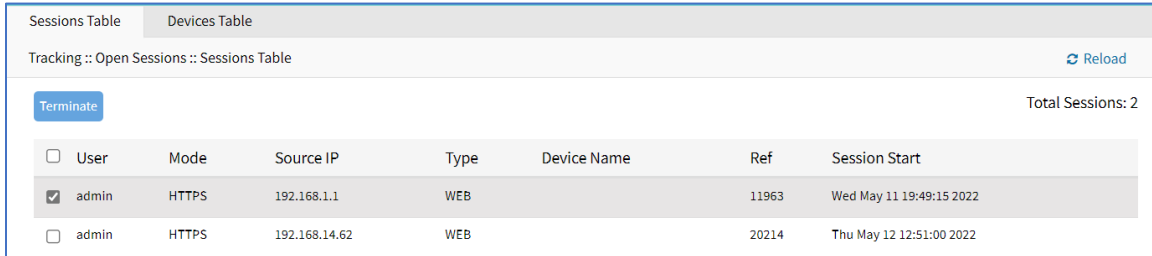

<input type="checkbox"/>	User	Mode	Source IP	Type	Device Name	Ref	Session Start
<input checked="" type="checkbox"/>	admin	HTTPS	192.168.1.1	WEB		11963	Wed May 11 19:49:15 2022
<input type="checkbox"/>	admin	HTTPS	192.168.14.62	WEB		20214	Thu May 12 12:51:00 2022

3. Click **Terminate**.

### Devices Table sub-tab

This shows information about active device sessions, the amount of connected session and the users which are connected.

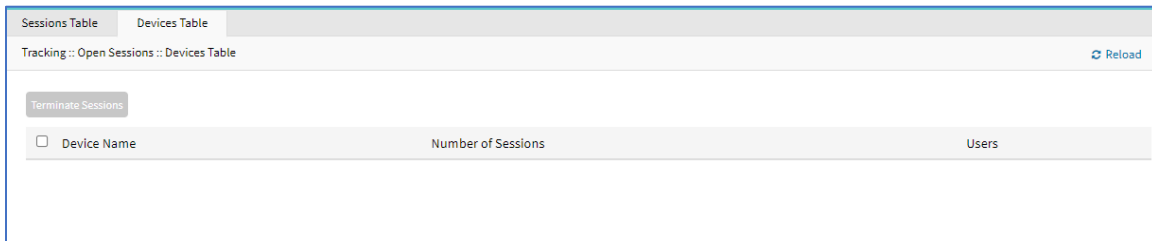

<input type="checkbox"/>	Device Name	Number of Sessions	Users

## Terminate Session

### WebUI Procedure

1. Go to *Tracking :: Open Sessions :: Sessions Table*.
2. In *Device Name* column, locate session and select checkbox.
3. Click **Terminate**.

## Event List tab

### Statistics sub-tab

This provides statistical information on the system event occurrences.

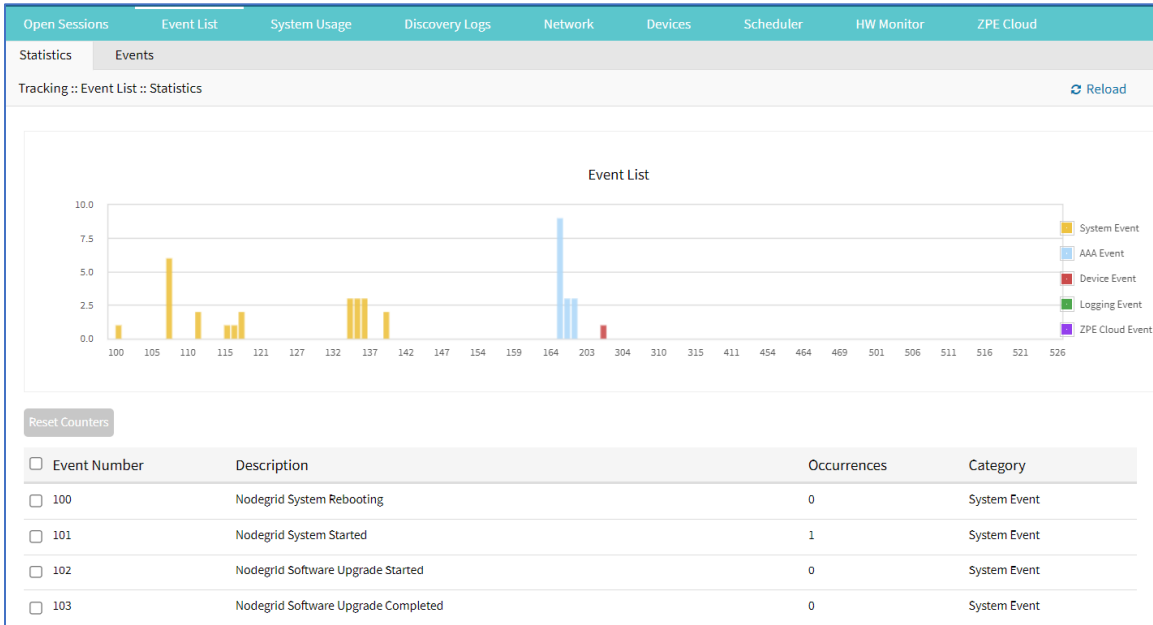

## Reset Event Counter

### WebUI Procedure

1. Go to *Tracking :: Event List :: Statistics*.
2. In *Event Number* column, locate the number and select checkbox (can select multiple).
3. Click **Reset Counters**.

### Events sub-tab

This displays event details (read only).

Date	Hostname	Event ID	Event Name	Description
2021-10-05T21:20:54Z	nodegrid	200	Nodegrid User Logged In	A user logged into the system. User: admin@192.168.14.46. Session type: HTTPS. Authentication Method: Local.
2021-10-05T21:20:16Z	nodegrid	201	Nodegrid User Logged Out	A user logged out of the system. User: admin. Session type: HTTPS.
2021-10-05T21:20:06Z	nodegrid	201	Nodegrid User Logged Out	A user logged out of the system. User: admin@192.168.14.46. Session type: HTTPS.
2021-10-05T21:13:08Z	nodegrid	200	Nodegrid User Logged In	A user logged into the system. User: admin@192.168.14.46. Session type: HTTPS. Authentication Method: Local.

## Export Event Listing to PDF

The PDF file can contain a maximum of 10,000 results. The list is based on the Filter fields and the **From** and **To** dates.

### WebUI Procedure

1. Go to *Tracking :: Event List :: Events*.
2. (optional) Enter **Filter** keyword.
3. (optional) Adjust **From** and **To** date/time, then click **Search**.
4. Click **Export to PDF**.
5. On Save dialog, navigate to the location, then click **Save**.

**Registered Events Description**

Event #	Description	Category
100	Nodegrid System Rebooting	System Event
101	Nodegrid System Started	System Event
102	Nodegrid Software Upgrade Started	System Event
103	Nodegrid Software Upgrade Completed	System Event
104	Nodegrid Configuration Settings Saved to File	System Event
105	Nodegrid Configuration Settings Applied	System Event
106	Nodegrid ZTP Started	System Event
107	Nodegrid ZTP Completed	System Event
108	Nodegrid Configuration Changed	System Event
109	Nodegrid SSD Life Left	System Event
110	Nodegrid Local User Added to System Datastore	System Event
111	Nodegrid Local User Deleted from System Datastore	System Event
112	Nodegrid Local User Modified in System Datastore	System Event
113	Nodegrid ZTP execution success	System Event
114	Nodegrid ZTP execution failure	System Event
115	Nodegrid Session Terminated	System Event
116	Nodegrid Session Timed Out	System Event
118	Nodegrid Power Supply State Changed	System Event
119	Nodegrid Power Supply Sound Alarm Stopped by User	System Event
120	Nodegrid Utilization Rate Exceeded	System Event

Event #	Description	Category
121	Nodegrid Thermal Temperature ThrottleUp	System Event
122	Nodegrid Thermal Temperature Dropping	System Event
123	Nodegrid Thermal Temperature Warning	System Event
124	Nodegrid Thermal Temperature Critical	System Event
126	Nodegrid Fan Status Changed	System Event
127	Nodegrid Fan Sound Alarm Stopped by User	System Event
128	Nodegrid Total number of local serial ports mismatch	System Event
129	Nodegrid dry contact change state	System Event
130	Nodegrid License Added	System Event
131	Nodegrid License Removed	System Event
132	Nodegrid License Conflict	System Event
133	Nodegrid License Scarce	System Event
134	Nodegrid License Expiring	System Event
135	Nodegrid Shell Started	System Event
136	Nodegrid Shell Stopped	System Event
137	Nodegrid Sudo Executed	System Event
138	Nodegrid SMS Executed	System Event
139	Nodegrid SMS Invalid	System Event
140	Nodegrid Connection Up	System Event
141	Nodegrid Connection Down	System Event
142	Nodegrid SIM Card Swap	System Event
144	Network Failover Executed	System Event
145	Network Failback Executed	System Event
150	Nodegrid Cluster Peer Online	System Event
151	Nodegrid Cluster Peer Offline	System Event

Event #	Description	Category
152	Nodegrid Cluster Peer Signed On	System Event
153	Nodegrid Cluster Peer Signed Off	System Event
154	Nodegrid Cluster Peer Removed	System Event
155	Nodegrid Cluster Peer Became Coordinator	System Event
156	Nodegrid Cluster Coordinator Became Peer	System Event
157	Nodegrid Cluster Coordinator Deleted	System Event
158	Nodegrid Cluster Coordinator Created	System Event
159	Nodegrid Cluster Peer Configured	System Event
160	Nodegrid Search Unavailable	System Event
161	Nodegrid Search Restored	System Event
200	Nodegrid User Logged In	AAA Event
201	Nodegrid User Logged Out	AAA Event
202	Nodegrid System Authentication Failure	AAA Event
300	Nodegrid Device Session Started	Device Event
301	Nodegrid Device Session Stopped	Device Event
302	Nodegrid Device Created	Device Event
303	Nodegrid Device Deleted	Device Event
304	Nodegrid Device Renamed	Device Event
305	Nodegrid Device Cloned	Device Event
306	Nodegrid Device Up	Device Event
307	Nodegrid Device Down	Device Event
308	Nodegrid Device Session Terminated	Device Event
310	Nodegrid Power On Command Executed on a Device	Device Event
311	Nodegrid Power Off Command Executed on a Device	Device Event
312	Nodegrid Power Cycle Command Executed on a Device	Device Event

Event #	Description	Category
313	Nodegrid Suspend Command Executed on a Device	Device Event
314	Nodegrid Reset Command Executed on a Device	Device Event
315	Nodegrid Shutdown Command Executed on a Device	Device Event
400	Nodegrid System Alert Detected	Logging Event
401	Nodegrid Alert String Detected on a Device Session	Logging Event
402	Nodegrid Event Log String Detected on a Device Event Log	Logging Event
410	Nodegrid System NFS Failure	Logging Event
411	Nodegrid System NFS Recovered	Logging Event
450	Nodegrid Datapoint State High Critical	Logging Event
451	Nodegrid Datapoint State High Warning	Logging Event
452	Nodegrid Datapoint State Normal	Logging Event
453	Nodegrid Datapoint State Low Warning	Logging Event
454	Nodegrid Datapoint State Low Critical	Logging Event
460	Nodegrid Door Unlocked	Logging Event
461	Nodegrid Door Locked	Logging Event
462	Nodegrid Door Open	Logging Event
463	Nodegrid Door Close	Logging Event
464	Nodegrid Door Access Denied	Logging Event
465	Nodegrid Door Alarm Active	Logging Event
466	Nodegrid Door Alarm Inactive	Logging Event
467	Nodegrid PoE Power Fault	Logging Event
468	Nodegrid PoE Power Budget Exceeded	Logging Event

## System Usage tab

This presents information usage details. The sub-tabs provide read-only information.

## Memory Usage sub-tab

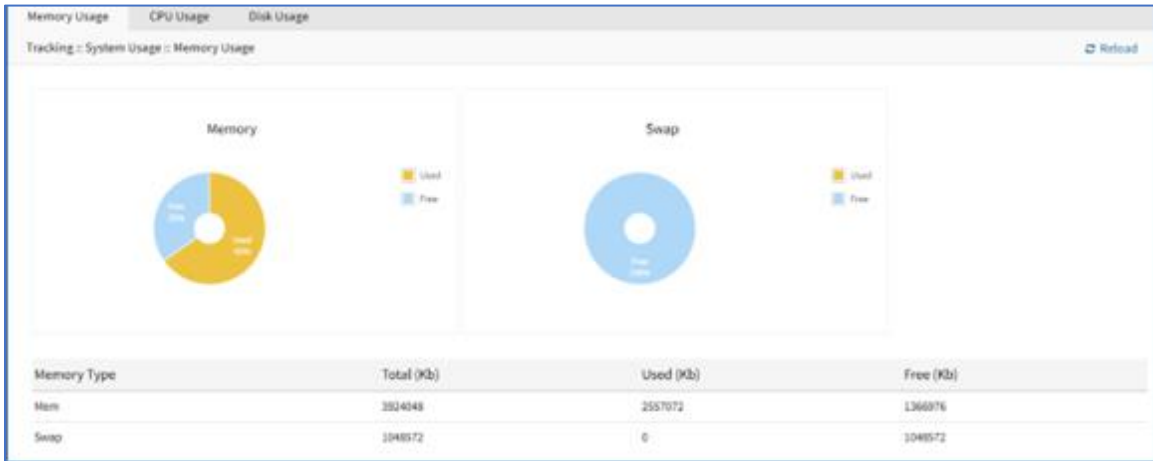

## CPU Usage sub-tab

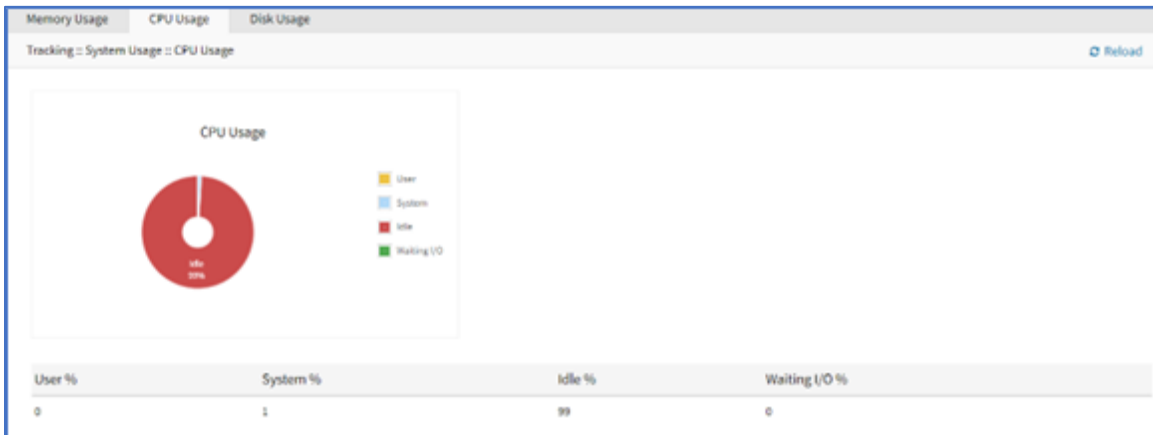

## Disk Usage sub-tab

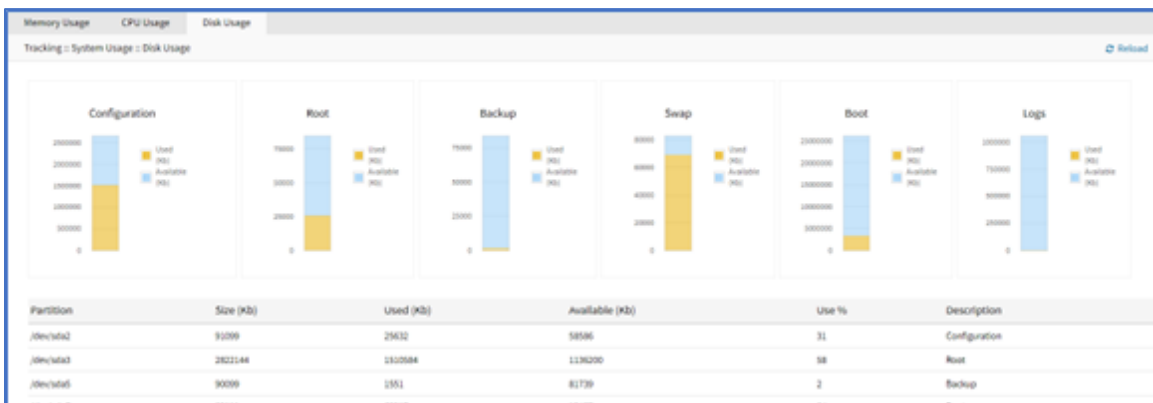

## Discovery Logs tab

This shows the logs of the discovery processes set on the Managed Devices setting for auto discovery.



Date	IP Address	Device Name	Discovery Method	Action
------	------------	-------------	------------------	--------

## Manage Logs

### Reset Logs

#### WebUI Procedure

1. Go to *Tracking :: Discovery Logs*.
2. Click **Reset Logs**.

The table is cleared.

## Network tab

This displays network Interface information, LLDP, Routing Table, IPsec Table, and Hotspot details.

**NOTE:** The displayed sub-tabs can change depending on the device configuration.

### Interface sub-tab

This displays the network interface statistics, like state, package counters, collisions, dropped and errors.

IfName	IfIndex	State	Rx Packets	Tx Packets	Collisions	Dropped	Errors
eth0	6	Up	40763	25914	0	0	0
eth1	5	Down	0	0	0	0	0
eth2	7	Up	25311	0	0	0	0
loopback	3	Up	0	148	0	0	0
loopback0	4	Up	0	147	0	0	0

## Review Interface Details

#### WebUI Procedure

1. Go to *Tracking :: Network :: Interface*.
2. Click on an Interface (displays dialog):

Cancel

### Detailed Statistics

IfName:

Speed(Mb/s):

Duplex:

Collisions:

#### Rx Statistics

Rx Packets:

Rx Bytes:

Rx Errors:

Rx CRC Errors:

Rx Dropped:

Rx FIFO Errors:

Rx Compressed:

Rx Frame Errors:

Rx Length Errors:

Rx Missed Errors:

Rx Over Errors:

#### Tx Statistics

Tx Packets:

Tx Bytes:

Tx Errors:

Tx Carrier errors:

Tx Dropped:

Tx FIFO Errors:

Tx Compressed:

Tx Aborted Errors:

Tx Heartbeat Errors:

Tx Window Errors:

Review details:

**Detailed Statistics** (IfName, Speed, Duplex, Collisions)

**Rx Statistics** (Rx Packets, Rx Bytes, Rx Errors, Rx CRC Errors, Rx Dropped, Rx FIFO Errors, Rx Compressed, Rx Frame Errors, Rx Length Errors, Rx Missed Errors, Rx Over Errors)

**Tx Statistics** (Tx Packets, Tx Bytes, Tx Errors, Tx Carrier errors, Tx Dropped, Tx FIFO Errors, Tx Compressed, Tx Aborted Errors, Tx Heartbeat Errors, Tx Window Errors)

3. **Cancel** button returns to the **Interface** sub-tab.

## Switch Interfaces sub-tab

Interface	Status	State	Speed	Rx Packets	Tx Packets	Description
netS1	Enabled	Down	-	0	0	This is a switch interface netS1.
netS2	Enabled	Down	-	0	0	
netS3	Enabled	Down	-	0	0	
netS4	Enabled	Down	-	0	0	

## MSTP sub-tab (Net SR only)

Interface	Switch Interfaces	MSTP	LLDP	Routing Table	MAC Table	IPsec	Wireguard	Hotspot	QoS	DHCP	Flow Exporter
Tracking :: Network :: MSTP <span style="float: right;">↻ Reload</span>											
Notice: Spanning Tree is Disabled in Switch :: Global											
MST Instance	VLAN List					Priority					
0	1-2					32768					

### View MSTP Instance Details

#### WebUI Procedure

1. Go to *Tracking :: Network :: MSTP*.
2. In *MST Instance* column, click on name (displays dialog).

Interface	Switch Interfaces	MSTP	LLDP	Routing Table	MAC Table	IPsec	Wireguard	Hotspot	QoS	DHCP	Flow Exporter
Tracking :: Network :: MSTP :: 0 <span style="float: right;">↻ Reload</span>											
Return											
Interface	MST State					MST Role					

3. Click **Return**.

## LLDP sub-tab

(read only) This shows devices that advertise their identity and capabilities on the LAN. LLDP advertising and reception can be enabled in Nodegrid with network connections.

Interface	LLDP	Routing Table	IPsec	Wireguard	Hotspot	QoS		
Tracking :: Network :: LLDP <span style="float: right;">↻ Reload</span>								
Connection	Type	Chassis ID	Port ID	Port Description	Age	System Name	IPv4 Mgmt Addr	IPv6 Mgmt Addr
Local Chassis	TX	mac e4:1a:2c:00:2c:42	ifname	ifname		nodegrid.localdomain	192.168.7.20	fe80::bcab:4aff:fe24:151,fe80::acc9:fdff:feb2:fc95,fe80::e61a:2cff:fe0c

## Routing Table sub-tab

(read only) This shows the routing rules that Nodegrid follows for network communications. Any added static network routes are included.

Interface	Switch Interfaces	LLDP	Routing Table	MAC Table	IPsec	Wireguard	Hotspot	QoS	DHCP	Flow Exporter
Tracking :: Network :: Routing Table <span style="float: right;">↻ Reload</span>										
Destination	Gateway	Metric	Interface	From	Table					
0.0.0.0/0	192.168.7.1	0	eth0	192.168.7.26	eth0					
0.0.0.0/0	192.168.7.1	90	eth0	all	main					
192.168.7.0/24	-	0	eth0	192.168.7.26	eth0					
192.168.7.0/24	-	90	eth0	192.168.7.26	eth0					
192.168.7.0/24	-	90	eth0	all	main					
192.168.7.26	-	0	eth0	192.168.7.26	eth0					

### MAC Table sub-tab

(read only) This displays information in MAC settings.

Interface	Switch Interfaces	LLDP	Routing Table	MAC Table	IPsec	Wireguard	Hotspot	QoS	DHCP	Flow Exporter
Tracking :: Network :: MAC Table <span style="float: right;">↻ Reload</span>										
Search: <input type="text"/>										
<input type="button" value="Refresh"/>										
Entry	Interface	VLAN	MAC Address							

### IPsec sub-tab

(read only) This displays information for each IPsec tunnel connection.

Interface	Switch Interfaces	LLDP	Routing Table	MAC Table	IPsec	Wireguard	Hotspot	QoS	DHCP	Flow Exporter
Tracking :: Network :: IPsec <span style="float: right;">↻ Reload</span>										
Tunnel Name	Authentication Protocol	Connected Since	Bytes Received	Bytes Sent	Right ID					

To appear on the IPsec list, Monitoring must be enabled for each IPsec tunnel.

### Wireguard sub-tab

This shows the Wireguard connection details.

Interface	Switch Interfaces	LLDP	Routing Table	MAC Table	IPsec	Wireguard	Hotspot	QoS	DHCP	Flow Exporter
Tracking :: Network :: Wireguard <span style="float: right;">↻ Reload</span>										
Interface Name	Listening Port	Peers								

## View Details on Wireguard Configuration

### WebUI Procedure

1. Go to *Tracking :: Network :: Wireguard*.
2. In *Interface Name* column, click on a name (displays dialog of details):

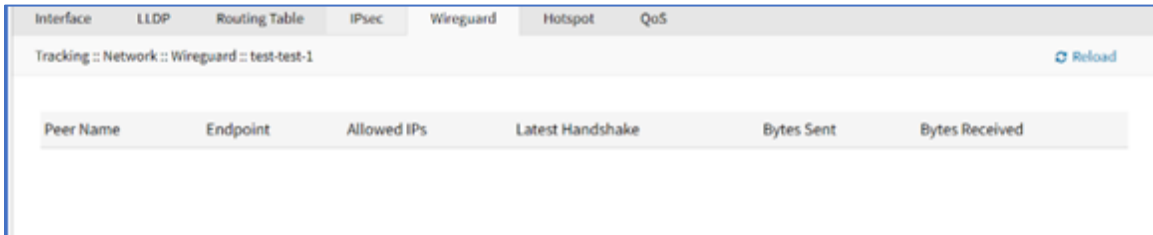

Peer Name	Endpoint	Allowed IPs	Latest Handshake	Bytes Sent	Bytes Received
-----------	----------	-------------	------------------	------------	----------------

3. Review details.

### Hotspot sub-tab

(read-only) This displays all devices currently connected to the hotspot.

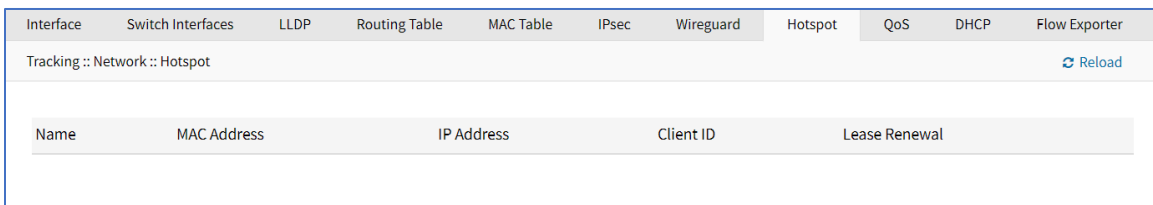

Name	MAC Address	IP Address	Client ID	Lease Renewal
------	-------------	------------	-----------	---------------

### QoS sub-tab

(read only) This displays traffic information from each configured QoS (Quality of Service) class/interface. If the QoS interface is bidirectional, two entries are shown (one for input and one for output).

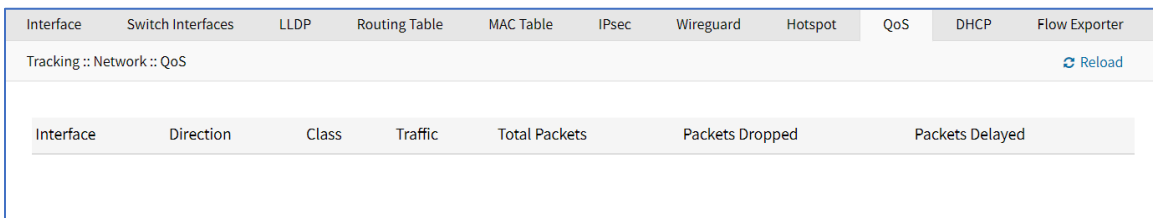

Interface	Direction	Class	Traffic	Total Packets	Packets Dropped	Packets Delayed
-----------	-----------	-------	---------	---------------	-----------------	-----------------

### DHCP sub-tab

(read-only) This displays DHCP information.

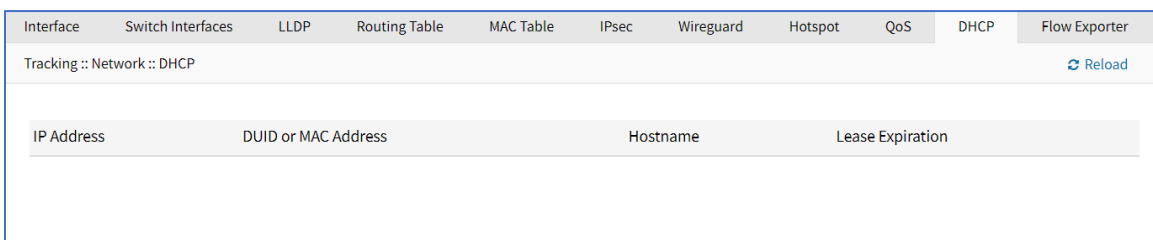

IP Address	DUID or MAC Address	Hostname	Lease Expiration
------------	---------------------	----------	------------------

## Flow Exporter sub-tab

(read-only) This displays Flow Exporter details.

Interface   Switch Interfaces   LLDP   Routing Table   MAC Table   IPsec   Wireguard   Hotspot   QoS   DHCP   Flow Exporter					
Tracking :: Network :: Flow Exporter					<a href="#">Reload</a>
Name	Interface	Flows	Packets	Bytes	

## Devices tab

This shows connection statistics for physically connected devices, like serial and USB devices, and wireless modems. The available options will depend on the specific Nodegrid unit.

The screenshot shows the Nodegrid web interface. At the top, there's a search bar and user information. Below that is a navigation menu with icons for Access, Tracking, System, Network, Managed Devices, Cluster, Security, Auditing, and Dashboard. A secondary menu highlights 'Devices' with sub-options: Serial Statistics, USB devices, Bluetooth, Wireless Modem, GPS, and GEO Fence.

## Serial Statistics sub-tab

This provides statistical information on the serial ports connectivity such as transmitted and received data, RS232 signals, errors.

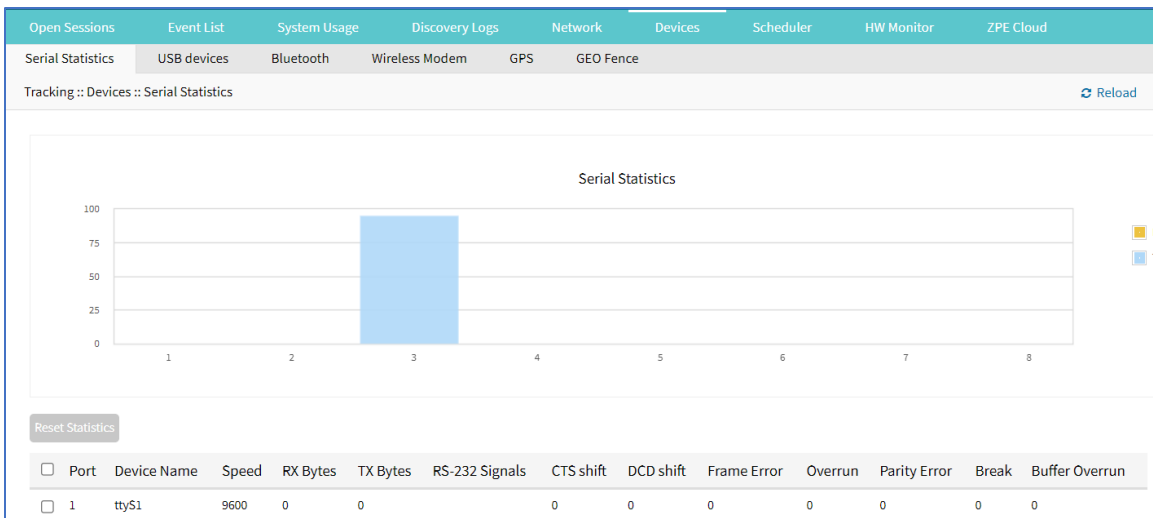

## Reset Statistics

### WebUI Procedure

1. Go to *Tracking :: Devices :: Serial Statistics*.

- Select checkboxes next to Port numbers.

Reset Statistics													
<input type="checkbox"/>	Port	Device Name	Speed	RX Bytes	TX Bytes	RS-232 Signals	CTS shift	DCD shift	Frame Error	Overrun	Parity Error	Break	Buffer Overrun
<input checked="" type="checkbox"/>	1	ttyS1	9600	0	0		0	0	0	0	0	0	0
<input type="checkbox"/>	2	ttyS2	9600	0	0		0	0	0	0	0	0	0
<input type="checkbox"/>	3	ttyS3	9600	0	0		0	0	0	0	0	0	0

- Click **Reset Statistics**.

## USB devices sub-tab

This provides details about connected USB devices and initialized drivers.

Serial Statistics	USB devices	Bluetooth	Wireless Modem	GPS	GEO Fence
Tracking :: Devices :: USB devices					<a href="#">Reload</a>
USB Port	USB Path	USB ID	Detected Type	Kernel Device	Description
2	1-4	058f:6387	Storage	sdS2	Mass Storage
4	1-1.1	2f47:2282	USB Hub	hub	K/M Adapter
1-1.1.1	1-1.1.1	2f47:2283	Unknown	(none)	K/M Adapter

## View USB Device Details

### WebUI Procedure

- Go to *Tracking :: Devices :: USB devices*.
- In *USB Port* column, click on name (displays dialog)

USB devices
Bluetooth
Wireless Modem
GPS
GEO Fence

Tracking :: Devices :: USB devices :: 0572:1340

Return

USB Port:	S1-A
Bus:Dev:	3:2
USB Path:	3-1
VendorID:ProductID:	0572:1340
Detected Type:	Unknown
Kernel Device:	(none)
Manufacturer:	Conexant
Description:	USB Modem
Number of Interfaces:	2
Driver(s):	cdc_acm cdc_acm

3. Review details.
4. Click **Return** to go back.

## Convert M2 Analog Modem to USB Serial Device

### WebUI Procedure

1. Go to *Tracking :: Devices :: USB devices*.
2. In *USB Port* column, click on name of a M.2 Analog Modem.
3. On the dialog, click **Set as Serial Device**.
4. Click **Save**.

## Convert USB Analog Modem to USB Serial Device

### WebUI Procedure

1. Go to *Tracking :: Devices :: USB devices*.
2. In *USB Port* column, click on name of a USB Analog Modem (displays dialog).
3. On the dialog, click **Set as Serial Device**.
4. Click **Save**.



## Bluetooth sub-tab

This displays information about Bluetooth devices.

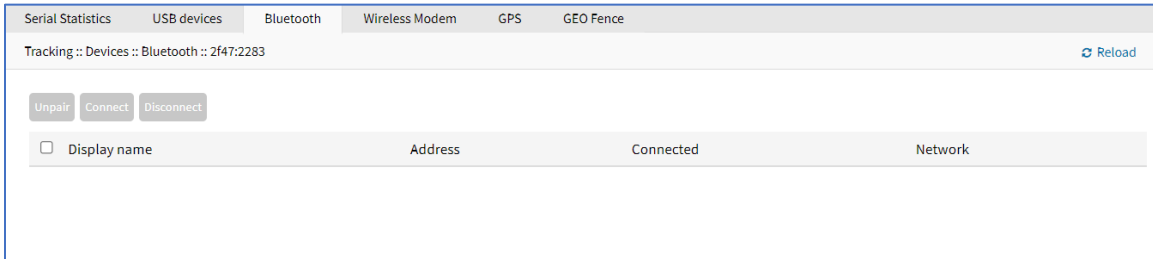

### Unpair Bluetooth

#### WebUI Procedure

1. Go to *Tracking :: Devices :: Bluetooth*.
2. Select checkbox.
3. Click **Unpair**.

### Connect Bluetooth

#### WebUI Procedure

1. Go to *Tracking :: Devices :: Bluetooth*.
2. Select checkbox.
3. Click **Connect**.

### Disconnect Bluetooth

#### WebUI Procedure

1. Go to *Tracking :: Devices :: Bluetooth*.
2. Select checkbox.
3. Click **Disconnect**.

## Wireless Modem sub-tab

This displays information about wireless modem.

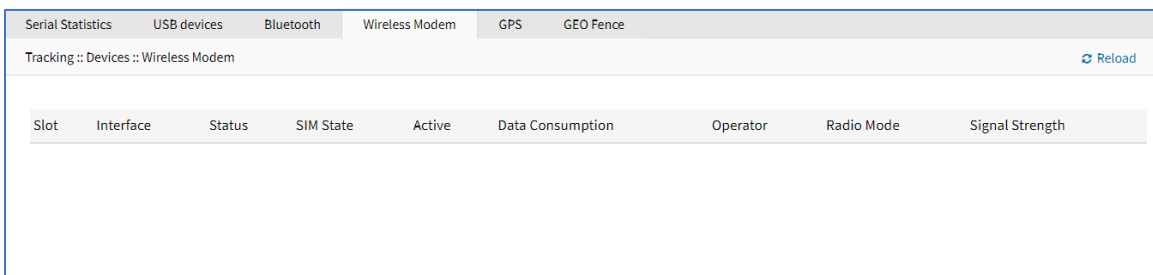

## View Wireless Modem Details

### *WebUI Procedure*

1. Go to *Tracking :: Devices :: Wireless Modem*.
2. In *Slot* column, click on name (displays dialog).

Serial Statistics   USB devices   Bluetooth   **Wireless Modem**   GPS   GEO Fence

Tracking :: Devices :: Wireless Modem :: Channel-A

[Return](#)

### Modem Information

Slot: Channel-A

Modem Model: EM7565

Firmware Version: SW9X50C\_01.14.02.00

Hardware Version: 1.0

Carrier Configuration: ATT

Equipment ID (IMEI): 353533101043225

Interface: cdc-wdm0

Status: Disconnected

Current Operator: AT&T MicroCell

Temperature (Celsius): 55

### Network Information

Active SIM Card: SIM 1

IP Family: --

IP Address: --

IP Gateway: --

IP Primary DNS: --

Carrier MTU: --

Bytes Accumulated SIM 1: 0

Bytes Accumulated SIM 2: 0

SIM data usage monitoring should be enabled in Network :: Connections.

### SIM 1 Information

Data Usage    Signal Strength

[Reset](#)

Last Update: Tue Nov 23 13:18:53 2021

SIM Status: Active

Subscriber ID: 310410256791820

Circuit Card ID: 89014103272567918202

Operator: AT&T MicroCell

Phone Number Discovered:

SIM State: Registered

Connection: LTE

Signal Strength: 67%

### SIM 2 Information

Data Usage    Signal Strength

[Reset](#)

Last Update:

SIM Status: Inactive

Subscriber ID:

Circuit Card ID:

Operator:

Phone Number Discovered:

SIM State:

Connection:

Signal Strength: 0%

3. Review details.

4. Click **Return** to go back.

### GPS sub-tab

This provides information about GPS details (when installed).

Slot	Coordinates (Lat,Lon)	Distance (m)	Update Time (UTC)	Device Name
Configured Coordinates (Lat,Lon): 0,0				

### GEO Fence sub-tab

(if enabled) This provides map of GEO Fence location. View can be zoomed in or out.

Update Time (UTC)	Coordinates (Lat,Lon)	Distance (m)	Device Name

### Scheduler tab

This provides information about scheduled tasks.

Task Name	User	Date	PID	Event	Error
<input type="button" value="Reset Log"/>					

## Reset Log

### WebUI Procedure

1. Go to *Tracking :: Scheduler*.
2. Select checkbox to reset.
3. Click **Reset**.

## HW Monitor tab

(ready only) This displays Nodegrid system hardware information.

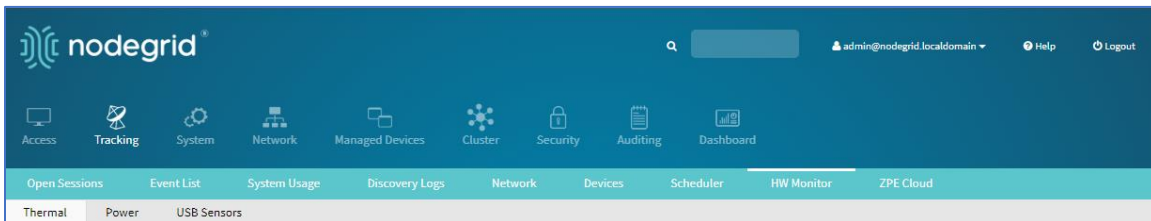

### Thermal sub-tab

Go to *Tracking :: HW Monitor :: Thermal*.

This displays the current CPU temperature, System temperature, and FAN speeds (if available).

Thermal			
Tracking :: HW Monitor :: Thermal <span style="float: right;">Reload</span>			
Name	Value	Unit	Description
CPU Temperature	61	Celsius	CPU temperature

### Power sub-tab

Go to *Tracking :: HW Monitor :: Power*.

This displays information about current Power sources (current state and power consumption).

Power			
Tracking :: HW Monitor :: Power <span style="float: right;">Reload</span>			
Name	Value	Unit	Description
PS	ON	NA	Power Supply State

### USB Sensors sub-tab

Go to *Tracking :: HW Monitor :: USB Sensors*.

**NOTE:** The details shown depend on the Nodegrid device.

Name	Value	Unit	Description
------	-------	------	-------------

Nodegrid USB Temperature and Humidity Sensors are automatically discovered by the System (usb\_sensor). After detection, it must be enabled to use with monitoring and alarm management.

Click a sensor to open a detail page. A click on the **Sensor Status** button displays more details and specifics.

x

Sensors Status

Name	Value	Unit	Description
<b>Description</b>		<b>Value</b>	
Name	usb53-8		
Status	Unknown		
Type	usb_sensor		
Mode	Enabled		
Licensed	Yes		
Nodegrid Host	nodegrid-JamieNSR2.175.localdomain		
Groups	admin		

### ZPE USB Environmental Sensors and Actuators

ZPE USB Device	Description
THS-U01	Temperature and Humidity USB sensor, cable 2m (6.5ft)
AIR-U01	Air Flow and Temperature USB sensor, 0.15 to 1.0 m/s [30 to 200 fpm], cable 4m (13ft)
AIR-U02	Air Flow and Temperature USB sensor, 0.5 to 10.0 m/s [100 to 2,000 fpm], cable 4m (13ft)
DOOR-01	Proximity sensor, cable 4m (13ft) - Requires IO8-U01
RL4-U01	4-port Relay via USB, cable 3m (10ft)
IO8-U01	8-port GPIO via USB, cable 3m (10ft)

ZPE USB Device	Description
BCON-U01	Beacon with alarm USB, black base, blue light, cable 3m (10ft)
BCON-U05	Beacon, no alarm USB, black base, clear light, cable 5m (16ft)
SMK-U01	Smoke detector, cable 3m (10ft) - Requires IO8-U01 and RL4-U01

### Supported USB Sensors

USB Device	Vendor
USB Serial	FTDI, CP2105, CP210X
USB KVM	ZPE KVM-U01 - KVM over USB dongle (VGA, USB kb, USB mouse)
USB Sensor	ZPE Environmental: THS-U01 - temperature & humidity, Degree Controls F200 - Air Velocity Sensor (paired with TTL-232R-3V3 or TTL-232R-5V converter cable)
USB Analog Modem	Zoom, US Robotics
USB Cellular Modem	USB620L, USB730L
USB 1G Ethernet	Any USB 3.0 Gigabit Ethernet adapter
USB SFP Ethernet	Winyao USB1000F USB 3.0 Gigabit Fiber adapter
USB WiFi	Wireless Network adapter for Linux (TP-Link TL-WN722N)
USB Storage	Any USB flash drive

**NOTE:** These devices utilize Linux drivers supported by the System. Certain driver versions may not work as expected. If any issues occur, contact [support@zpesystems.com](mailto:support@zpesystems.com).

### Supported USB I/O Devices

USB I/O Device	Description	GPIO Input	Analog Input
Numato GP80001E	GPIO Module	8-On/Off	6-Any
Numato USBPOWRL001	Relay Module	No	4-Any
Delcom USB HID 9040XX	Light Tower	No	No
Patlite LR6-USB-W/K	Light Tower	No	No
TRH-320	Humidity and temperature sensors	No	1 Humidity - % 1 Temperature - °C

USB I/O Device	Description	GPIO Input	Analog Input
Degree Controls F200	Air temperature and velocity sensors	No	1 Air Temperature - °C 1 Air Velocity - m/s
Homologated Generic USB I/O Device	All in one	100-On/Off	100 generic - any

### Additional Supported USB Devices

USB i/O Device	GPIO output	Relay	Light	Buzzer
Numato GP80001E	UP TO 8 – On, Off	No	No	No
Numato USBPOWRL001	UP TO 4 – On, Off	2 – On, Off	No	No
Delcom USB HID 9040XX	No	No	3 – On, Off, continuous cycle	1 – On, Off, continuous cycle
Patlite LR6-USB-W/K	No	No	1 – On, Off, continuous cycle	1 – On, Off, continuous cycle
TRH-320	No	No	No	No
Degree Controls F200	No	No	No	No
Homologated Generic USB I/O Device	100 – On, Off	100 – On, Off	100 – On, Off, continuous cycle	100 – On, Off, continuous cycle
Numato GP80001E	UP TO 8 – On, Off	No	No	No
Numato USBPOWRL001	UP TO 4 – On, Off	2 – On, Off	No	No

### ***I/O Ports (GPIO) sub-tab (Gate SR/Link SR only)***

This shows the status of GPIO ports (only displayed for models with GPIO ports).

***Example – Nodagrid Gate SR WebUI***



The screenshot displays the 'Device Information' page for a ZPE Cloud connection. It is divided into four main sections:

- Device Information:** Fields for Device ID, Associated Company, and Associated Site, all showing '...'.
- Connection Status:** Status is 'Disconnected - Process not running'. Other fields include Last Public IP Connected, Total of Exchanged Messages, and Total of Exchanged Bytes, all showing '...'.
- Cloud Information:** Fields for URL and Version, both showing '...'.
- Connection Tracking:** Fields for Device Registration, First Connection, Last Reconnection, and Last Disconnection, all showing '...'.

## ZPE Cloud tab

This shows configured connections with the ZPE Cloud application.

This is a duplicate of the screenshot above, showing the same 'Device Information' page with fields for Device ID, Connection Status, Cloud Information, and Connection Tracking.

## SD-WAN tab

This shows configured underlay and overlay paths of SD-WAN tunnels.

The screenshot shows the Nodegrid dashboard interface. The top navigation bar includes the Nodegrid logo, a search bar, and user information. The main navigation menu contains icons for Access, Tracking, System, Network, Managed Devices, Cluster, Security, Auditing, and Dashboard. The bottom navigation bar has tabs for Open Sessions, Event List, System Usage, Discovery Logs, Network, Devices, Scheduler, HW Monitor, ZPE Cloud, and SD-WAN. The SD-WAN tab is currently selected.

Path status conditions are:

**Normal** (no issue related to SD-WAN)

**Warning** (SLA metrics are violated)

**Error** (All SLA metrics are violated, or path is down)

This only displays path information if SD-WAN is enabled. To verify, go to *Network :: SD-WAN :: Settings* and ensure **Enable SD-WAN** checkbox is selected. If disabled, the following message displays.

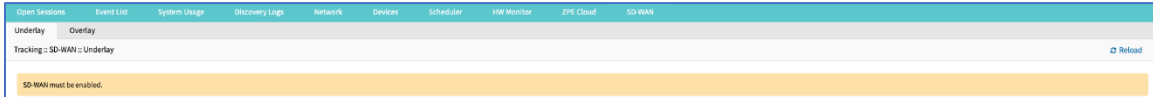

If topology is not yet configured inside the device, the following message displays.



If there is an error communicating with the SD-WAN daemon, the following message displays.



On the CLI, go to `/system/sdwan/` directory and use `show` command to display details..

```
[admin@SD745 ~]# cd system/sdwan/underlay/
[admin@SD745 underlay]# show
=====
interface link profile priority status latency jitter packet_loss bytes received bytes sent errors dropped
=====
eth0 l1_eth_f10608 1 up 22.6ms / 400ms 0.1ms / 50ms 0.0% / 5% 788788 2295720 0 0
eth1 l2_eth_f10608 2 up 0.0ms / 400ms 0.0ms / 50ms 100.0% / 5% 566382 688003 2 0
```

```
[admin@SD745 ~]# cd system/sdwan/overlay/
[admin@SD745 overlay]# show
=====
tunnel interface protocol status latency jitter packet_loss bytes received bytes sent errors dropped
=====
sdwan_vti0 eth0 IPsec down 0.0ms / 400ms 0.0ms / 50ms 0.0% / 5% 0 0 0 0
sdwan_vti1 eth1 IPsec down 0.0ms / 400ms 0.0ms / 50ms 0.0% / 5% 0 0 0 0
[admin@SD745 overlay]#
```

The values displayed under columns of latency, jitter, and packet loss; are the average and the threshold for each metric.

## Underlay sub-tab

This shows the status of the Underlay path.

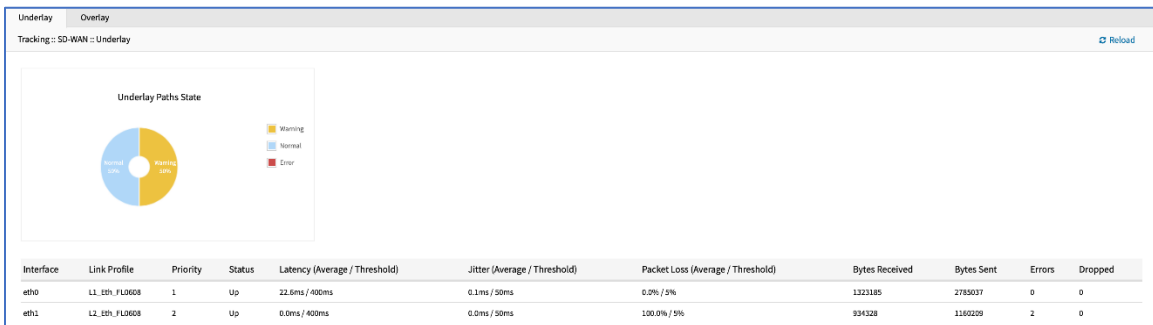

## Overlay sub-tab

This shows the status of the Overlay path.

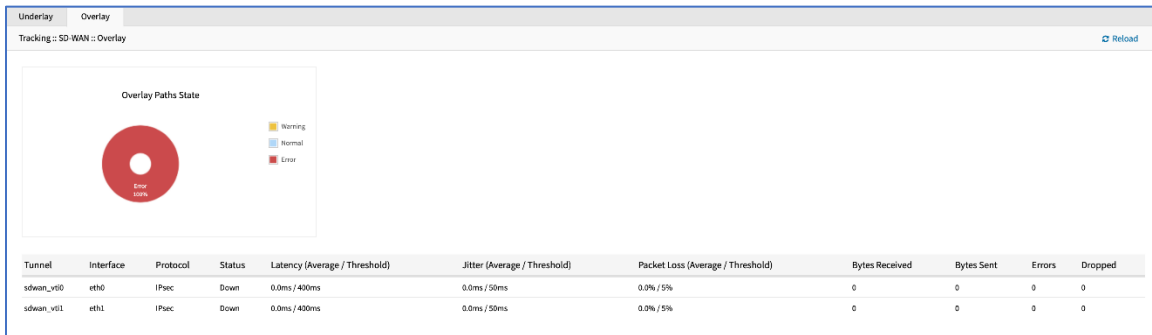

## System Section

System settings are configured for each device, including license keys, general system settings, firmware updates, backup and restore, and other device management configurations.

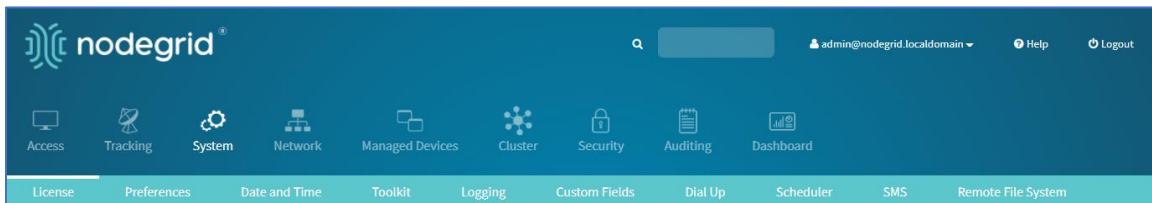

## License tab

This displays all licenses enrolled on this Nodegrid device, with license key, expiration date, application, etc. Number of licenses (used and available) are shown in upper right. Licenses can be added or deleted. If licenses expire or are deleted, the devices exceeding the total licenses changes status to "unlicensed" (information is retained in the System). Unlicensed devices are not shown on the Access tab.

For Nodegrid access and control, each managed device must have a license. The required license for each Nodegrid serial port is included with the device.

**NOTE:** A managed device is any physical or virtual device defined under Nodegrid for access and control.

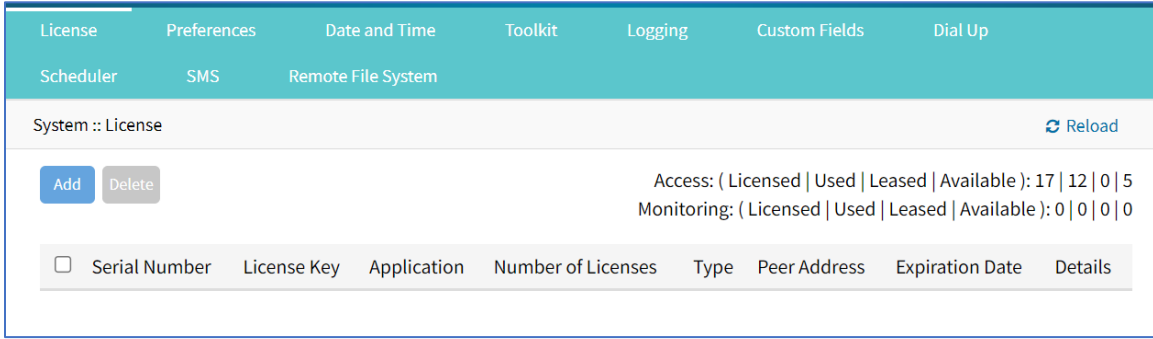

Available license details are listed on the right side.

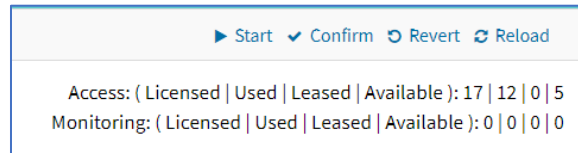

## Manage Licenses

### Add a License

#### WebUI Procedure

1. Go to *System :: License*.
2. Click **Add** (displays dialog).

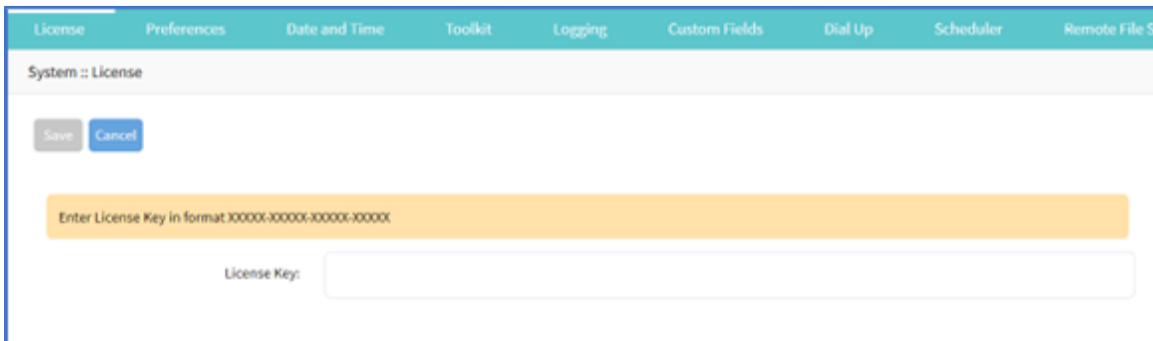

3. Enter **License Key**.
4. Click **Save**.

### Delete a License

#### WebUI Procedure

1. Go to *System :: License*.
2. Select the checkbox.
3. Click **Delete**.

## Preferences tab

Main system preferences are configured in this tab. Any change in the fields activates the **Save** button.

### Manage Preferences

Settings are provided with individual sections on the page.

#### Configure Nodegrid Device Preferences

1. Go to *System :: Preferences*.
2. In the *Nodegrid Location* menu:

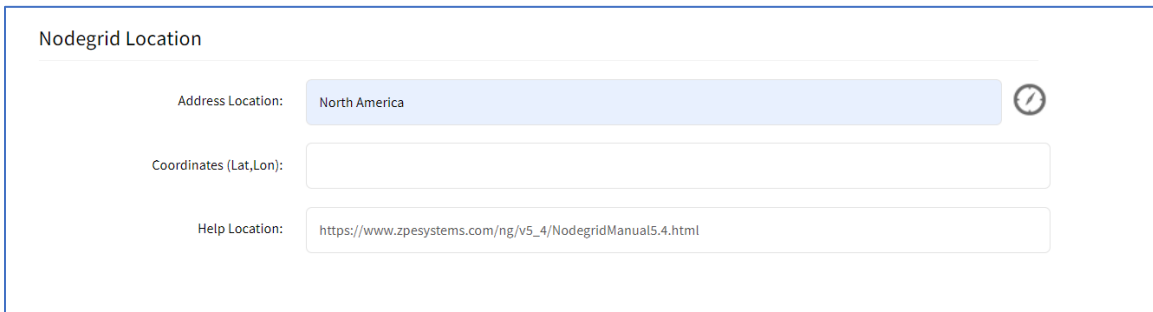

Enter **Address Location** (a valid address for the device location).

Enter **Coordinates (Lat, Lon)** (if GPS is available, click **Compass** icon  or manually enter GPS coordinates).

For **Help Location**, enter alternate URL location for the User Guide.

**NOTE:** The administrator can download the documentation from ZPE (HTML5 or PDF, as preferred) to be available for users (when **Help** icon is clicked).

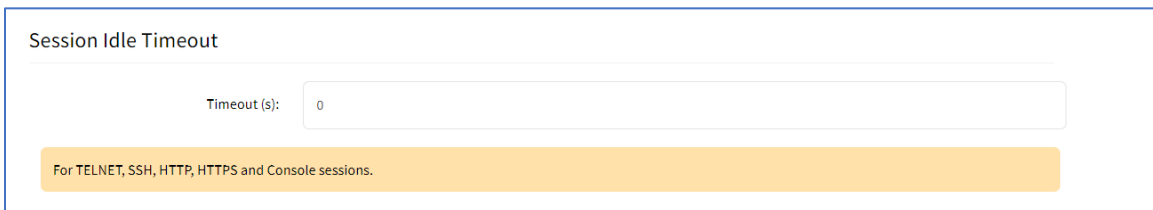

3. In the *Session Idle Timeout* menu (number of seconds of session inactivity until the session times out and logs the user off.) This setting applies to all telnet, SSH, HTTP, HTTPS, and Console sessions.

**NOTE:** Any change in value is applied on the next login.

In **Timeout (seconds)**, enter one of these:

**zero (0)** – the session will never expire.

Value (i.e., 6000 keeps session active for 100 minutes).

4. In the *Nodegrid Configuration* menu:

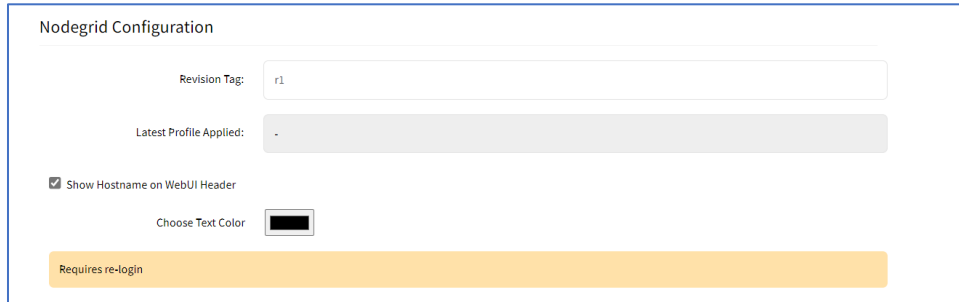

Enter **Revision Tag** (a free format string used as a configuration reference tag - can be manually updated or updated with an automated change management process).

The **Latest Profile Applied** (read-only) is the last applied profile (ZTP process or on ZPE Cloud).

(optional) Select **Show Hostname on WebUI Header** checkbox (displays the device hostname on the WebUI banner. **For Choose Text Color**, click in the color box and select color (click in color grid or enter RGB or CYMK values).

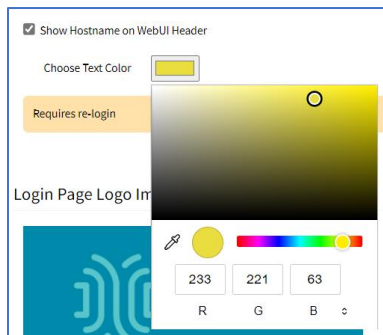

**NOTE:** For a color change to take effect, log out of the application and log in.

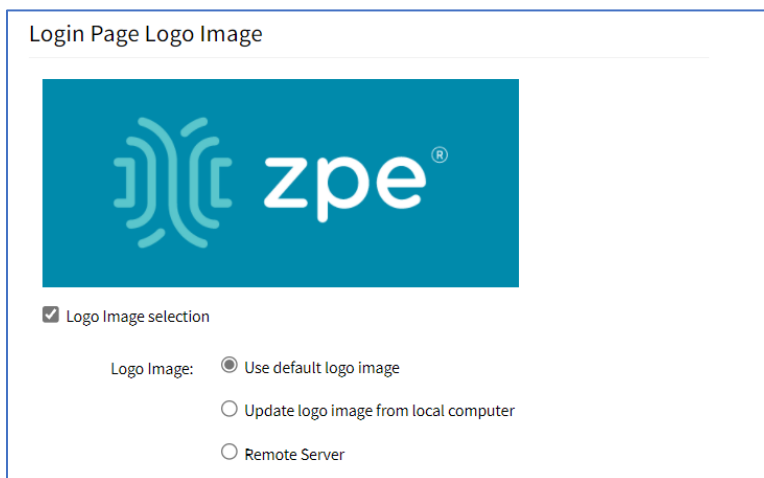

5. In the *Logo Page Logo Image* menu:

The administrator can change the logo image (png or jpg) used on the Nodegrid WebUI login. It can be uploaded from the local desktop or a remote server (FTP, TFTP, SFTP, SCP, HTTP, and HTTPS). This is the URL format (username and password may be required): `<PROTOCOL>://<Server Address>/<Remote File>`.

(optional) Select **Logo Image selection** checkbox.

In *Logo Image* menu, select one:

**Use default logo image** radio button.

**Update log image from local computer** radio button (expands dialog).

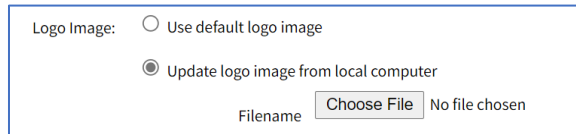

Click **Choose File** to locate and select logo (jpg, png).

**Remote Server** radio button (expands dialog).

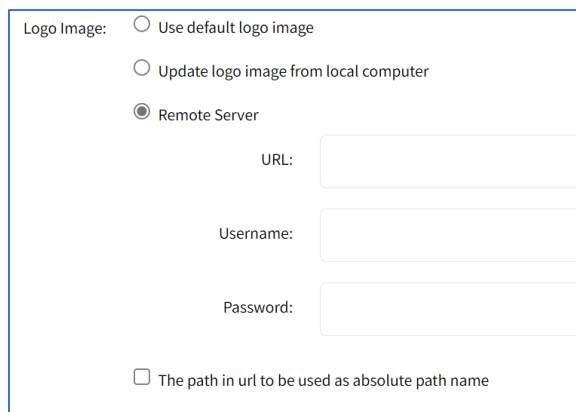

Enter **URL** (URL can be the IP address or hostname/FQDN. If using IPv6, use brackets [ ... ]. Supported protocols: FTP, TFTP, SFTP, and SCP.)

Enter **Username**.

Enter **Password**.

(optional) Select **The path in url to be used as absolute path name** checkbox.

After upload, refresh the browser cache to display the new image.

6. In the *Logo Banner Message* menu:

**NOTE:** Nodegrid can be configured to show a login banner on Telnet, SSHv2, HTTP, HTTPS and Console login. This banner is displayed on the device login page. The default content (below) can be edited.

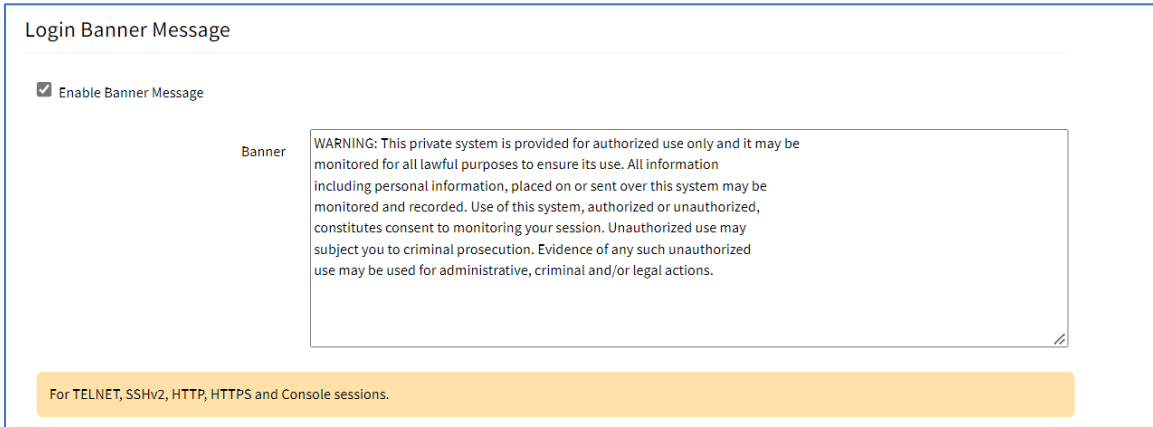

The message can include device-specific information, such as Device Alias or other device identifier details.

Click in **Banner** textbox.

Modify text, as needed (use *Enter* for hard returns).

7. In the *Utilization Rate Events* menu:

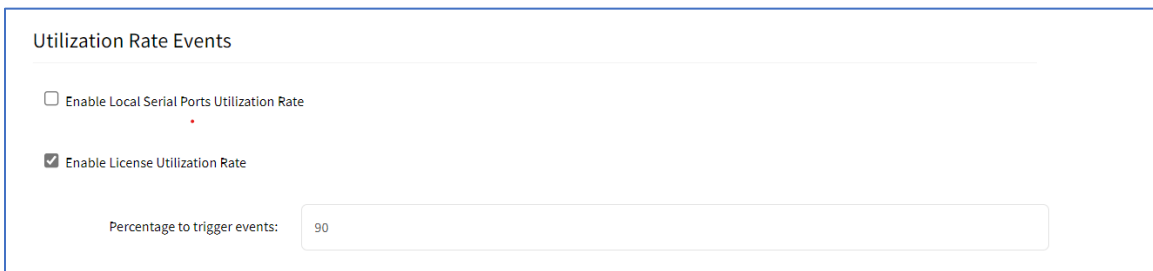

(optional) Select **Enable Local Serial Ports Utilization Rate** checkbox.

Select **Enable License Utilization Rate** checkbox and enter **Percentage to trigger events**. (An event notification is generated when the entered percentage is reached.)

8. In the *Serial Console* menu:

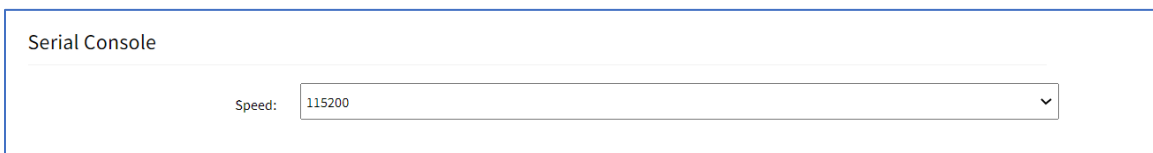

On **Speed** drop-down, select baud rate (**9600, 19200, 38400, 57600, 115200**).

9. In the *Power Supplies* menu:

**NOTE:** This displays only when device is equipped with 2 power supplies). Includes option to enable alarm when powered off.



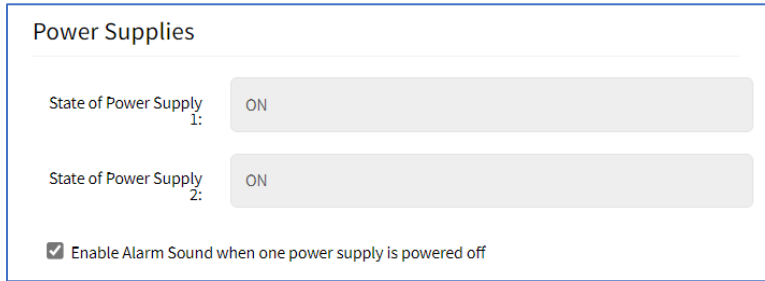

Select **Enable Alarm Sound when one power supply is powered off** checkbox.

10. In the *Fan Alarm* menu (displays only when device is equipped with fans):

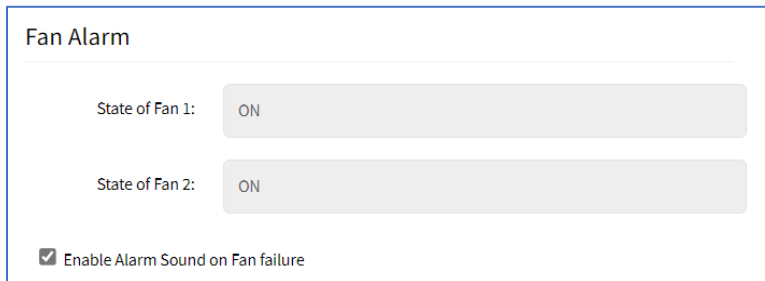

Select **Enable Alarm Sound on Fan Failure** checkbox.

11. In the *Network Boot* menu:

**NOTE:** Nodegrid can boot from a network ISO image.



Enter **Unit IPv4 Address**. (URL format:http://ServerIPAddress/PATH/FILENAME.ISO)

Enter **Unit Netmask**.

On **Unit Interface** drop-down, select one (**eth0**, **eth1**).

Enter **ISO URL**.

12. Review details, then click **Save**.

## Slots tab (SR only)

This information identifies slots on SR devices with installed modules.

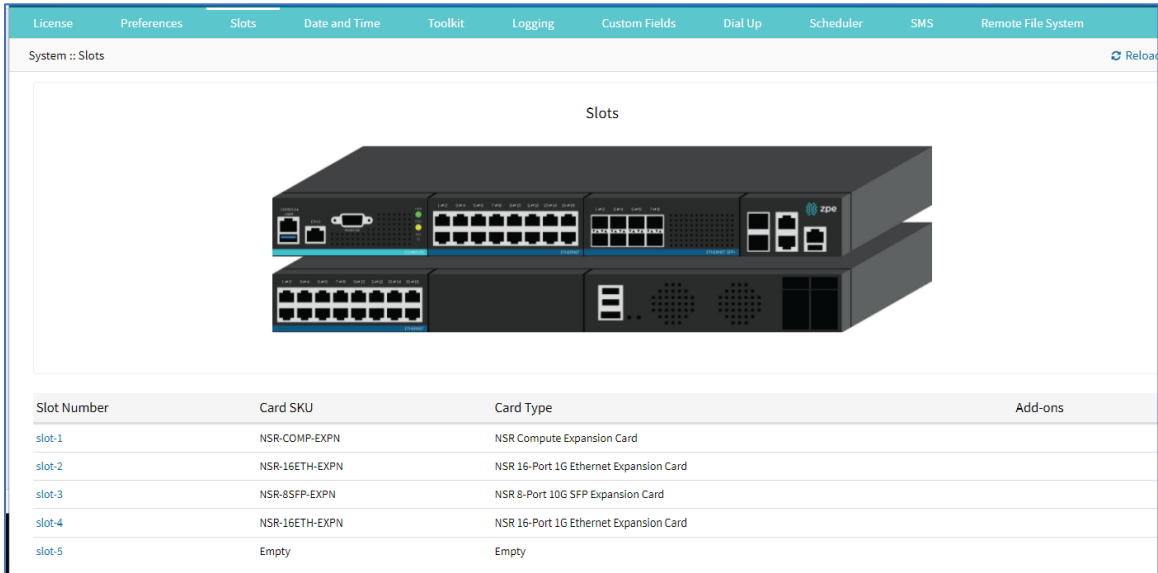

## Manage Slots

### Review Slot Details

1. Go to *System :: Slots*.
2. In the table, click on a slot name (displays dialog).

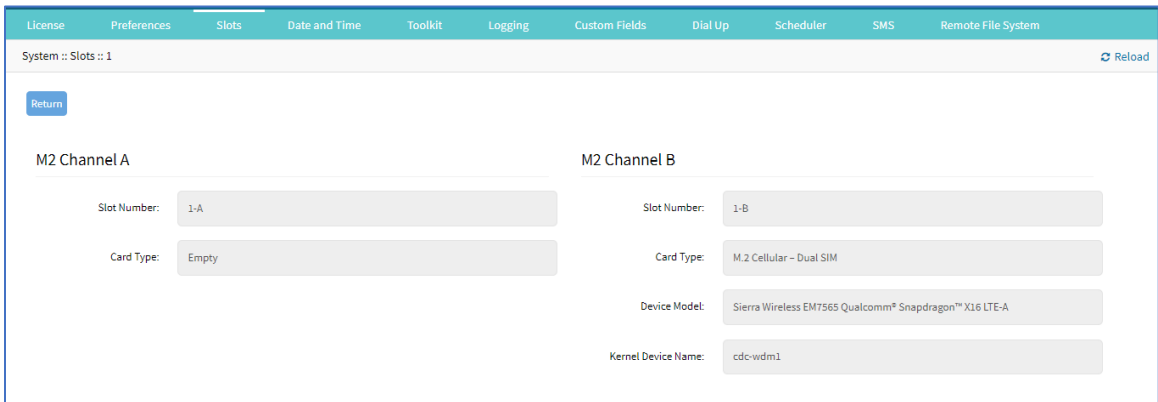

3. When done, click **Return**.

### Enable SATA Card in Slot 5

#### WebUI Procedure

1. Go to *System :: Slots*.
2. In the table, click on **Slot 5** (displays dialog).

System :: Slots :: 5

Save Return

Slot Number:

Card SKU:

Card Type:

Allow SATA card in slot 5

When SATA card is allowed in slot 5, MPCIE card in slot 4 can have only one SATA device

3. Select **Allow SATA card in slot 5** checkbox.
4. Click **Save**.

## Date and Time tab

Nodegrid devices supports NTP (Network Time Protocol) Authentication and Cellular Tower Synchronization. This default configuration automatically retrieves accurate date/time from any server in the NTP pool. NTP authentication provides an extra safety measure for Nodegrid to ensure that the timestamp it receives has been generated by a trusted source, protecting it from malicious activity or interception.

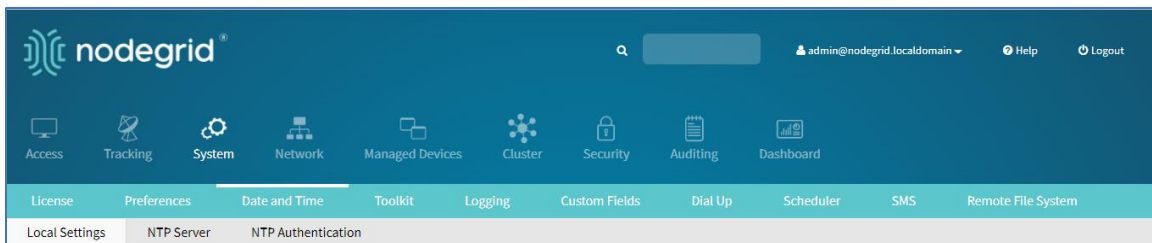

## Local Settings sub-tab

Local Settings NTP Server NTP Authentication

System :: Date and Time :: Local Settings ▶ Start ▼ Confirm ↺ Revert ↻ Reload

Save

**Date and Time**

Last query at:

Date and Time:  Auto via Network Time Protocol

Last update (UTC):

Server:

Manual

**Time Zone**

Options:

If needed, the date/time can be manually set. NTP is the default configuration. In manual configuration mode, Nodegrid device uses its internal clock to provide date and time information. Refresh the page to see the current system time. Date and time synchronization from cell tower is an additional convenience that obtains exact time directly from the carrier network.

To set the local time zone, select from the drop-down menu (default: UTC).

**NOTE:** All timestamps in Event Logs are in UTC.

### Configure Local Time

Use this dialog to setup local time and UTC time zone for the device location.

1. Go to *System :: Date and Time :: Local Settings*.
2. In *Date and Time* menu:

Select one:

**Auto via Network Time Protocol** radio button:

Enter **Server**.

**Manual** radio button (expands dialog):

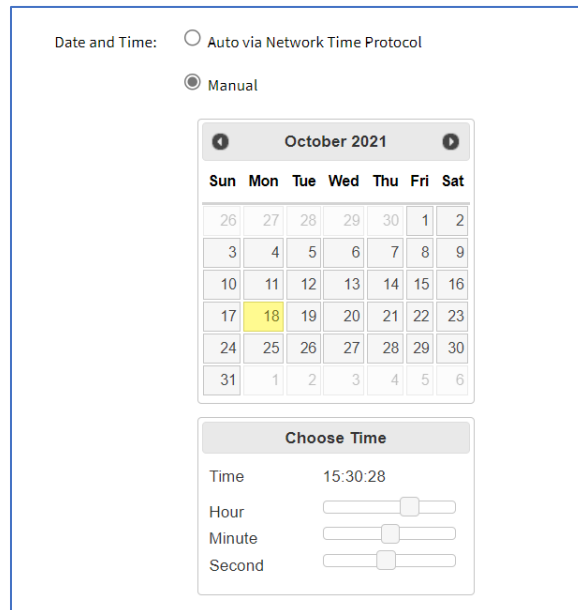

Date and Time:  Auto via Network Time Protocol  
 Manual

October 2021						
Sun	Mon	Tue	Wed	Thu	Fri	Sat
26	27	28	29	30	1	2
3	4	5	6	7	8	9
10	11	12	13	14	15	16
17	18	19	20	21	22	23
24	25	26	27	28	29	30
31	1	2	3	4	5	6

**Choose Time**

Time 15:30:28

Hour

Minute

Second

Scroll through **Calendar** and select date.

In **Choose Time**, enter hour, minute, second.

3. In *Time Zone* menu:  
On **Options** drop-down, select appropriate time zone.
4. Click **Save**.

## Cellular Tower Synchronization

This is supported by units with an installed Wireless Modem card and valid SIM card. The Nodegrid device can get date/time from the cellular tower. The SIM card must be registered to the carrier network).

1. Go to *System :: Date and Time :: Local Settings*.

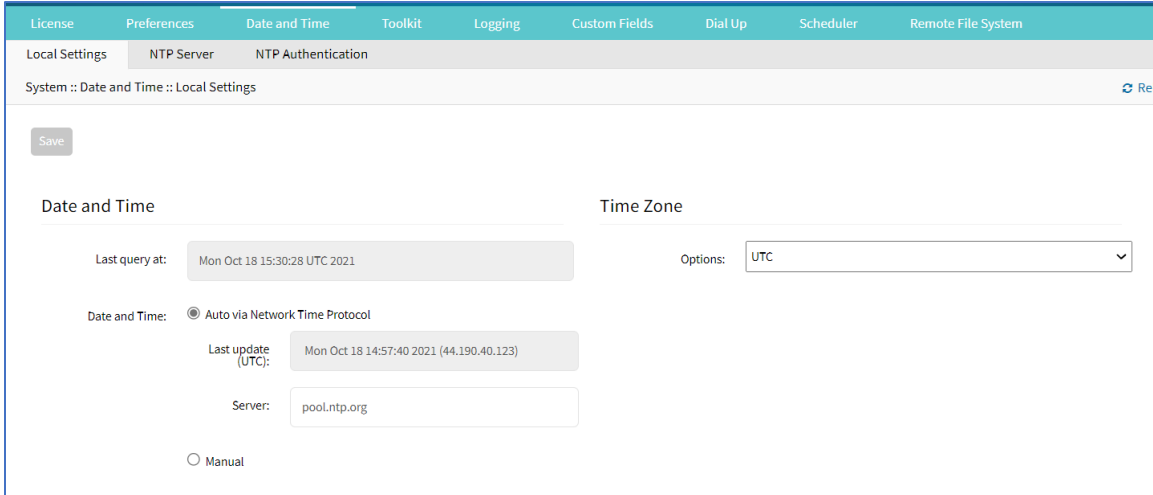

2. In *Cellular Tower Synchronization* menu:

Select **Enable Date and Time Synchronization** checkbox.

3. Make other changes, as needed.
4. Click **Save**.

**NOTE:** Both NTP and Cellular Tower Synchronization can be enabled. The last date/time received from either source is applied. This allows updated date/time with any connection failover configuration.

## NTP Server sub-tab

This page enables the NTP Server.

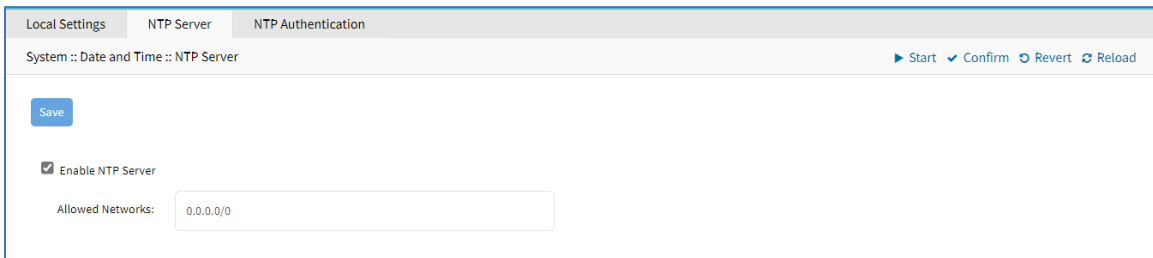

## Configure the local NTP server

1. Go to *System :: Date and Time :: NTP Server*.
2. Select **Enable NTP Server** checkbox.
3. In **Allowed Networks**, enter all allowed networks (comma-separated).

4. Click **Save**.

### NTP Authentication sub-tab

NTP reduces security risks associated with time synchronization. With authentication, there is assurance a generated response is from an expected source (rather than maliciously generated or intercepted). Authentication applies a list of agreed keys (passwords) between a server and a client. Communication between server and client is encrypted with one of the agreed keys appended to the messages. The appended key is un-encrypted to ensure it matches one of the agreed keys. Only then is action taken.

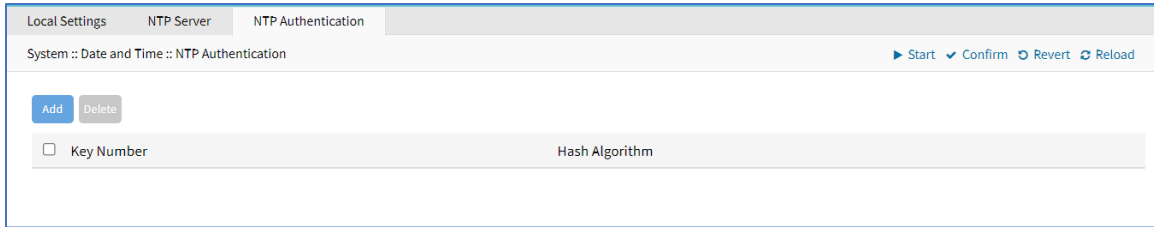

### Configure Key Number Set

This requires Admin privileges. Repeat the process for each key number set.

#### WebUI Procedure

1. Go to *System :: Date and Time :: NTP Authentication*.
2. Click **Add** (displays dialog).

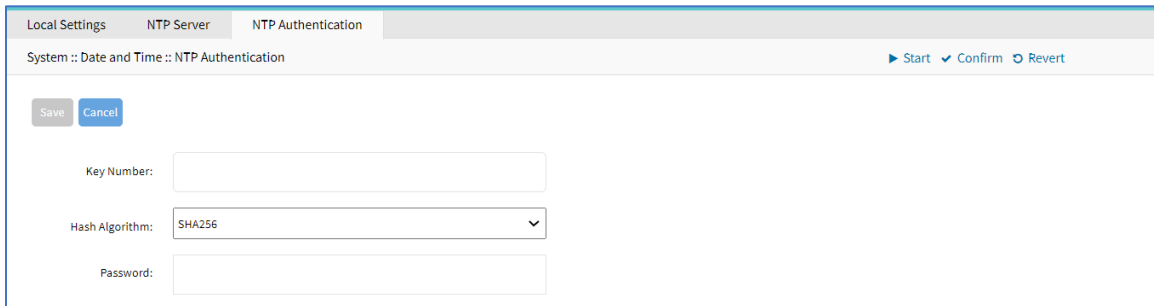

3. For **Key Number**, enter any unsigned integer (range: 1 to  $2^{32} - 1$ )
4. On **Hash Algorithm** drop-down, select one (**MD5, RMD160, SHA1, SHA256, SHA384, SHA512, SHA3-224, SHA3-256, SHA3-384, SHA3-512**).
5. For **Password**, enter a character string (space character not allowed).

Alternatively, enter a hexadecimal number with prefix **HEX** followed by the number **#####**.

6. Click **Save**.

### Delete Key Number

1. Go to *System :: Date and Time :: NTP Authentication*.
2. Select checkbox next to Key Number to delete.

3. Click **Delete**.

## Link the NTP server and Key Number

### WebUI Procedure

1. Go to *System :: Date and Time :: Local Settings*.
2. Use separator '|' (pipe) between server address and its key number.

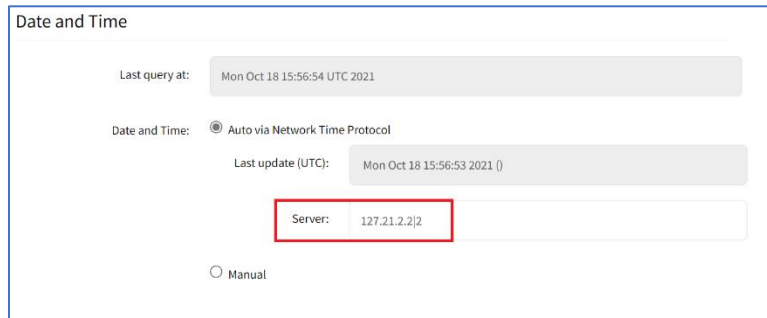

3. Make other changes, as needed.
4. Click **Save**.

## Toolkit tab

System maintenance features are available in *System :: Toolkit* page.

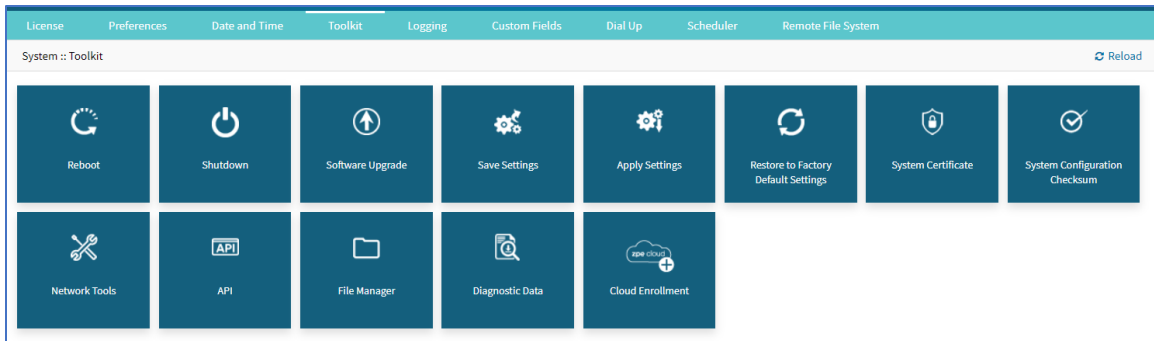

### Reboot tool

Reboot command is a graceful shutdown and reboot of the Nodegrid device. A warning message informs that all active sessions will be dropped. During a reboot, the operating system is automatically restarted.

On click, displays pop-up dialog. Click **OK** to continue.

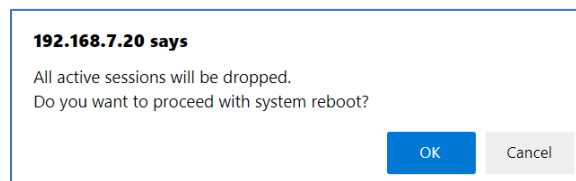

## Shutdown tool

On a shutdown, the operating system will be brought to a halted state. At this point, it is safe to drop the power supply to the unit (turn off power supplies or removing power cords). To turn the unit back on, the power supply must be stopped and then restarted.

On click, displays pop-up dialog. Click **OK** to continue.

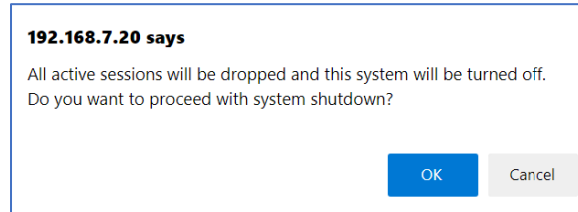

## Software Upgrade tool

Nodegrid can be updated via the WebUI or with the CLI.

1. Go to *System :: Toolkit*.
2. Click **Software Upgrade** icon (displays dialog)

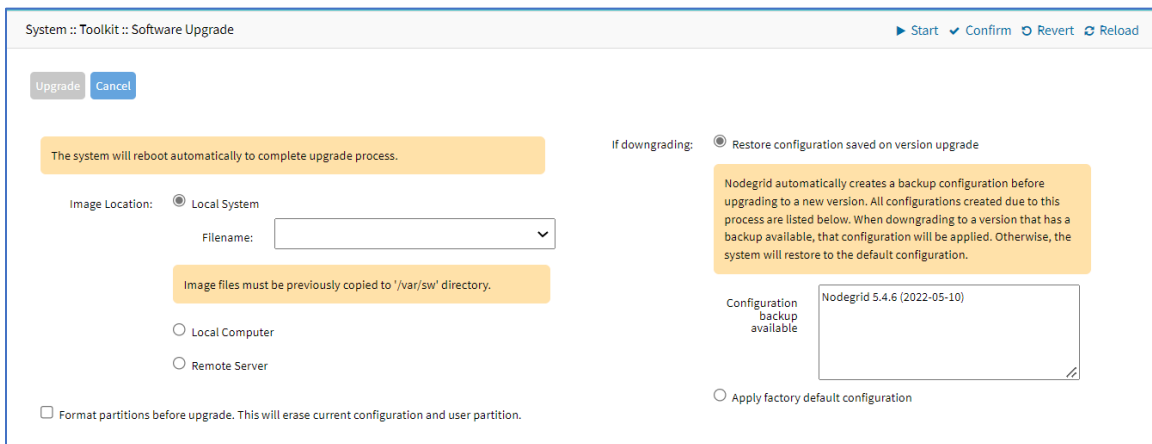

3. In *Image Location* menu, select one:  
**Local System** radio button (expands dialog).

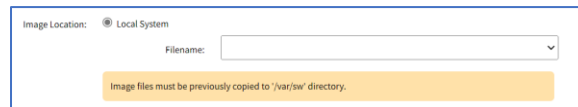

Enter **Filename**.

**NOTE:** Image files must be previously copied to '/var/sw' directory.

**Local Computer** radio button (expands dialog).



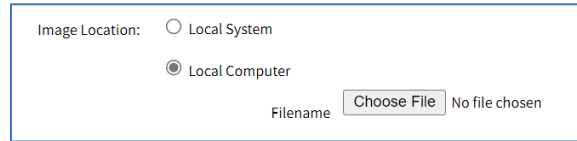

Click **Choose File**. On dialog, locate and select the file.

**Remote Server** radio button (expands dialog).

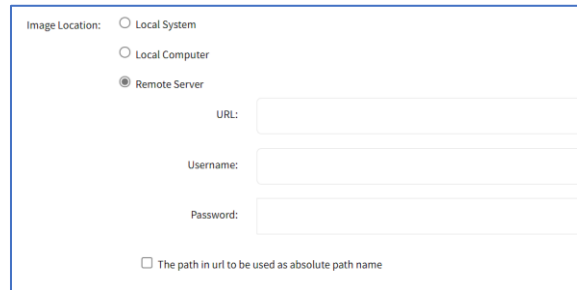

Enter **URL** (URL can be the IP address or hostname/FQDN).

**NOTE:** Supported protocols: FTP, TFTP, SFTP, SCP, HTTP, and HTTPS. URL can be the IP address or hostname/FQDN. (If using IPv6, include brackets [ ].)

Example: ftp://your-ftp-server-url/downloads/Nodegrid\_v5.6.1.iso

Enter **Username**.

Enter **Password**.

(optional) Select **The path in url to be used as absolute path name** checkbox.

4. (optional) select **Format partitions before upgrade. This will erase current configuration and user partition** checkbox.

5. In *If downgrading* section, select one:

**Restore configuration saved on version upgrade** radio button.

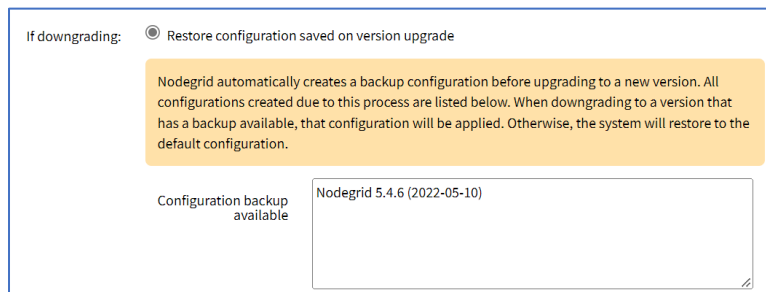

*Read the instructions.*

**Apply factory default configuration** radio button.

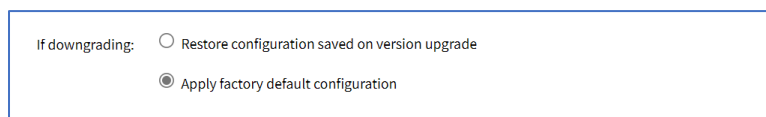

6. Click **Upgrade** (requires several minutes).

This version can be upgraded from previous release v4.2.4 or newer. If necessary, to upgrade from v3.2, v4.0, v4.1 or older v4.2 must first upgrade to v4.2.4, and then upgrade to v5.8.0.

Downgrade is only allowed to v4.2.4 or newer. UEFI mode and Secure Boot must be disabled prior to downgrading to v5.0 or older.

A status bar (WebUI only) displays progress of the software upgrade. When complete, a success dialog is displayed.



### CLI Procedure

To upgrade via the CLI, execute these commands:

```
[admin@nodegrid /]# software_upgrade
[admin@nodegrid {toolkit}]# show
```

The system will reboot automatically to complete upgrade process.

image\_location = local\_system

filename =

Image files must be previously copied to '/var/sw' directory.

format\_partitions\_before\_upgrade = no

if\_downgrading = restore\_configuration\_saved\_on\_version\_upgrade

If no configuration matches the version, factory default will be applied.

saved\_configurations:

Nodegrid 5.4.1 (2022-05-02)

Nodegrid 5.2.1 (2021-11-01)

### Save Settings tool

This saves current configuration. Displays this dialog.

1. Go to *System :: Toolkit*.
2. Click **Save Settings** icon (displays dialog).

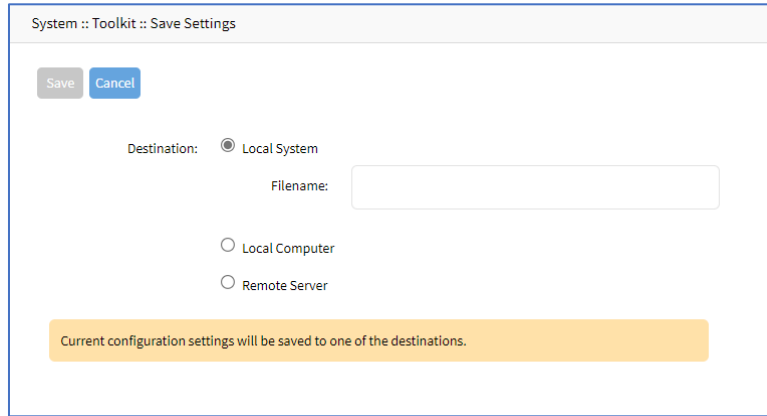

3. In *Destination* menu, select one.

**Local System** radio button (expands dialog).

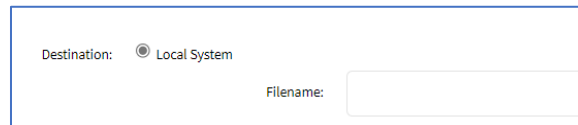

Enter **File Name**.

**Local Computer** radio button. Click **Save** (file is saved on the local computer *Download* folder).

**Remote Server** radio button (expands dialog).

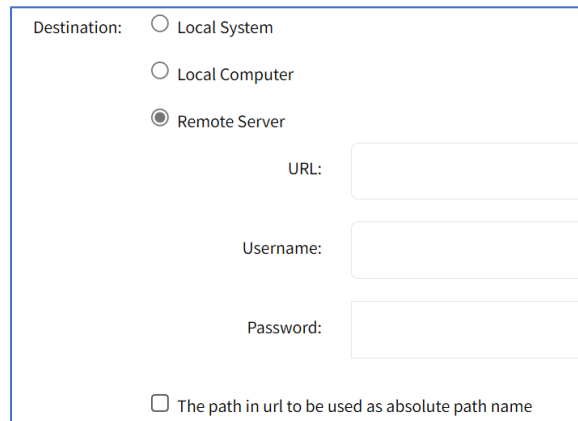

Enter **URL** (URL can be the IP address or hostname/FQDN. If using IPv6, use brackets [ ... ]. Supported protocols: FTP, TFTP, SFTP, and SCP.)

Enter **Username**.

Enter **Password**.

(optional) Select **The path in url to be used as absolute path name** checkbox.

**ZPE Cloud** radio button (expands dialog)

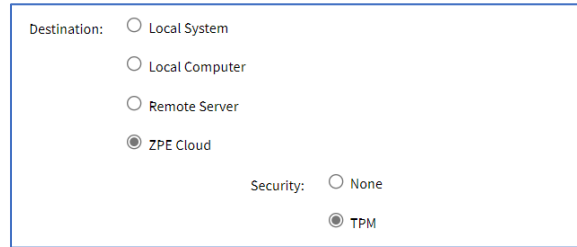

On *Security*, select one:

**None** radio button

**TPM** radio button

4. Click **Save**.

**NOTE:** The option to save to ZPE Cloud is only available if ZPE Cloud is enabled.

### Apply Settings tool

Saved configurations can be loaded from the Nodegrid device, a local connected computer, or from a remote server. When applied on the Nodegrid device, that becomes the new configuration. The server address can be the IP address or hostname/FQDN. If using IPv6, use brackets [ ... ]. Supported protocols: FTP, TFTP, SFTP, SCP, HTTP and HTTPS.

1. Go to *System :: Toolkit*.
2. Click **Apply Settings** icon (displays dialog).

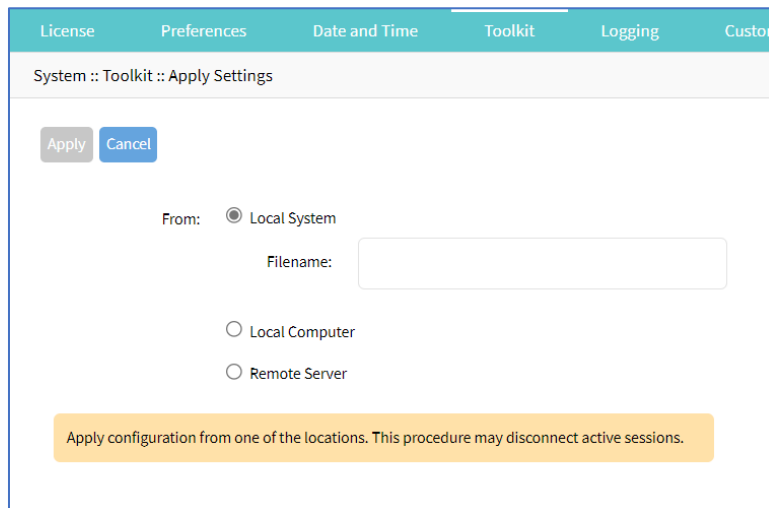

3. In *From* menu, select one:  
**Local System** radio button (expands dialog).

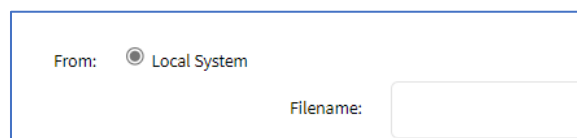

Enter **File Name**.

**Local Computer** radio button (expands dialog).

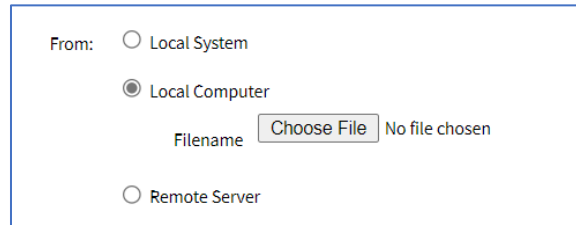

Click **Choose File** (locate and select the file).

**Remote Server** radio button (expands dialog).

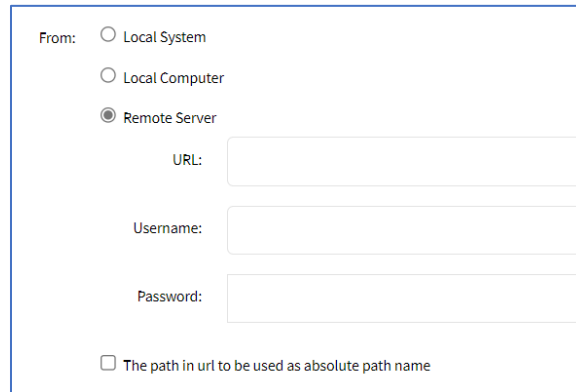

Enter **URL** (URL can be the IP address or hostname/FQDN. If using IPv6, use brackets [ ... ]. Supported protocols: FTP, TFTP, SFTP, and SCP.)

Enter **Username**.

Enter **Password**.

(optional) Select **The path in url to be used as absolute path name** checkbox.

4. Click **Apply**.

## **Restore to Factory Default Settings tool**

The Nodegrid solution offers multiple options to reset the unit back to factory default settings. Displays this dialog. The *System Profile* menu (**Out Of Band** or **Gateway**) is available on: Link SR, Bold SR, Gate SR, and Hive SR.

During this action, all configuration files are set to factory default. There is an option to save or clear all log files.

**NOTE:** Hard restore is available on the Nodegrid device. To use, locate the RST button on the chassis. Press the RST button down for at least 10 seconds. All configuration files are reset to defaults and log files are cleared. The RST button (reset to factory default) requires a minimum ET version of 80814T00. To determine the current version, see the *About* page details.

The system can also be reset by reformatting the whole system partition. This wipes all existing files and resets the system back to the shipped state.

1. Go to *System :: Toolkit*.

2. Click **Restore to Factory Default Settings** icon (displays dialog).

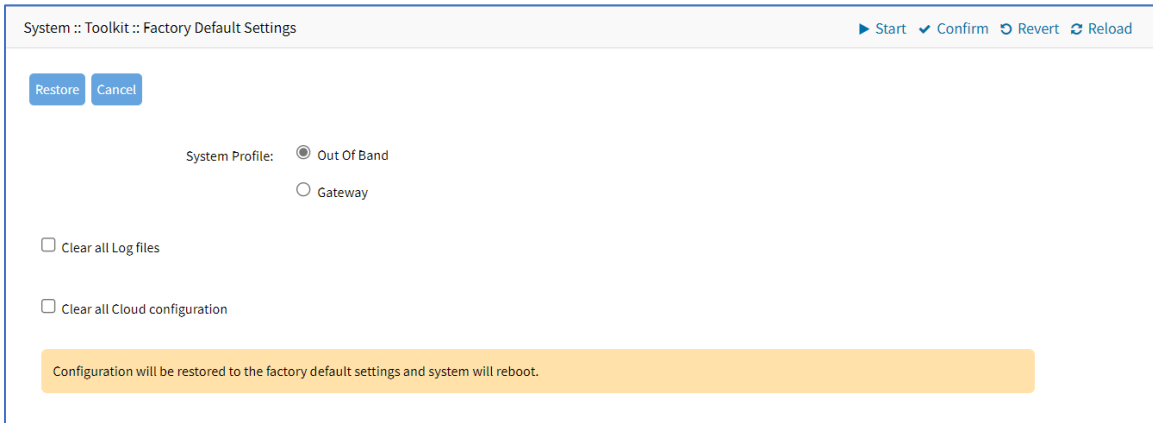

3. In the *System Profile* menu, select one: (for more information, see [System Profile](#)).
  - Out of Band** radio button.
  - Gateway** radio button.
4. (optional) Select **Clear all Log files** checkbox.
5. (optional) Select **Clear all Cloud Configuration** checkbox.
6. Click **Restore**.

## System Certificate tool

A certificate can be loaded to the Nodegrid device from a connected local computer or a remote server. On the dialog, there are two sub-tabs: **Upload Certificate** and **Create CSR**.

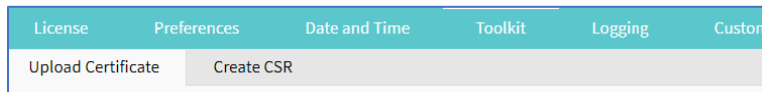

**WARNING!** When the certificate is applied, the web server is restarted and active sessions are disconnected.

The protocols FTP, TFTP, SFTP, SCP, HTTP, and HTTPS are supported.

## Upload Certificate

### WebUI Procedure

1. Go to *System :: Toolkit*.
2. Click **System Certificate** icon (displays *Upload Certificate* sub-tab dialog).

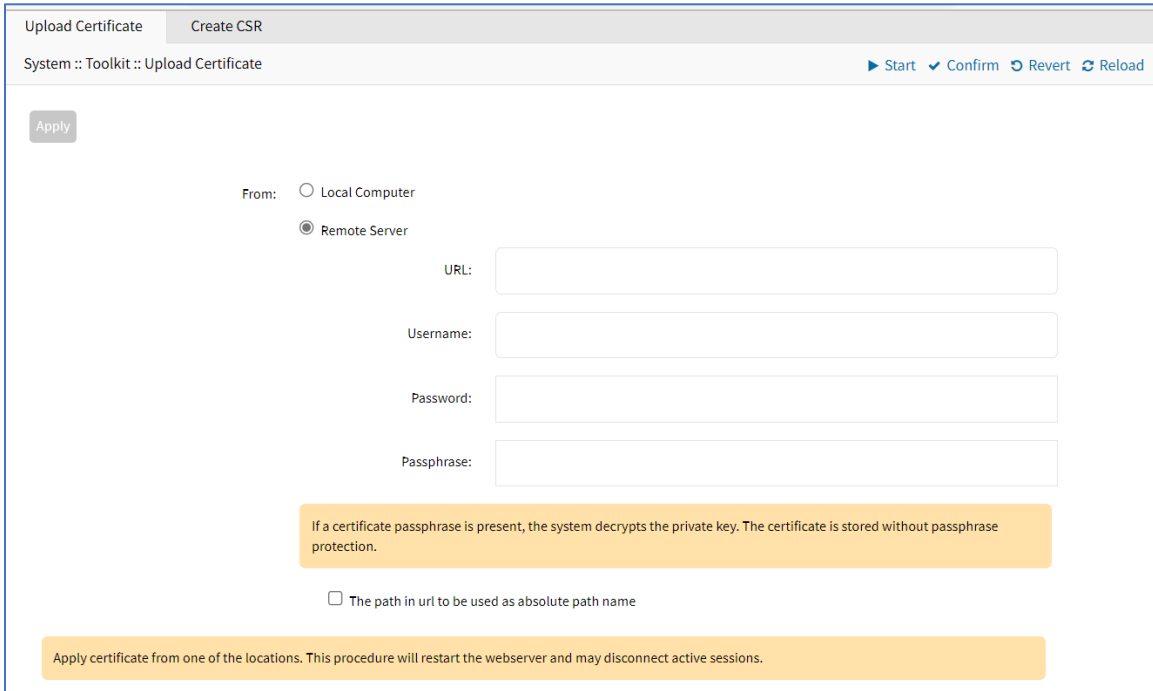

3. On *From* menu, select one.

**Local Computer** radio button (expands dialog).

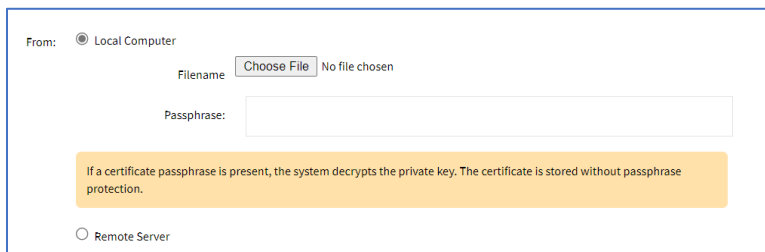

Click **Choose File** (locate and select the file). Enter **Passphrase**.

**Remote Server** radio button (expands dialog).

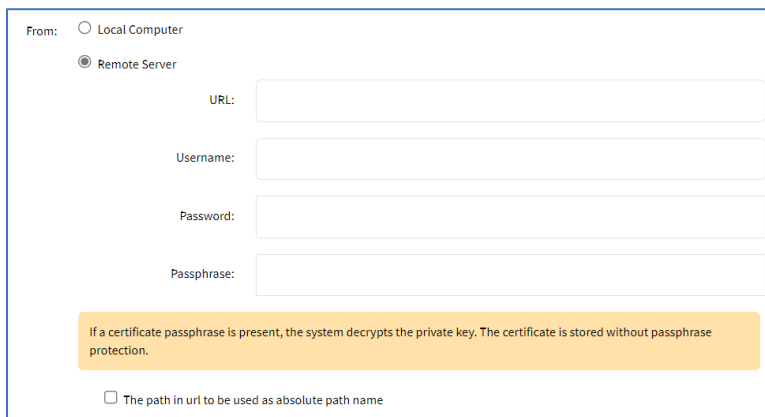

**NOTE:** Importing an encrypted certificate (with the Passphrase) is supported.

Enter **URL** (URL can be the IP address or hostname/FQDN. If using IPv6, use brackets [ ... ]).  
Supported protocols: FTP, TFTP, SFTP, and SCP.)

Enter **Username**.

Enter **Password**.

Enter **Passphrase**.

(optional) Select **The path in url to be used as absolute path name** checkbox.

4. Click **Apply**.

## Create a Self-Sign Certificate

A self-sign certificate can be created and applied directly in the Nodegrid.

### WebUI Procedure

1. Go to *System :: Toolkit*.
2. Click **System Certificate** icon (displays dialog).
3. On the **Create CSR** sub-tab:

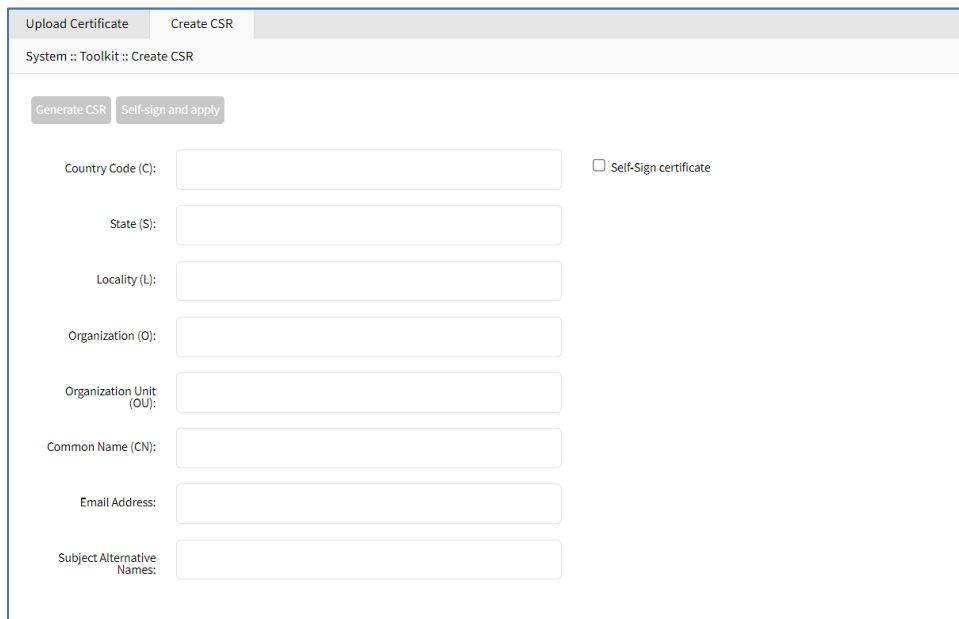

Enter **Country Code (C)**.

Enter **State (S)**.

Enter **Locality (L)**.

Enter **Organization (O)**.

Enter **Organization Unit (OU)**.

Enter **Common Name (CN)**.

Enter **Email Address**.



(optional) **Subject Alternative Names.**

4. Select **Self-Sign certificate** checkbox.

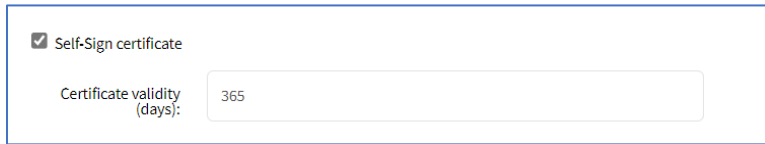

A screenshot of a web form. At the top, there is a checked checkbox labeled "Self-Sign certificate". Below it, there is a text input field labeled "Certificate validity (days):" with the number "365" entered inside.

Enter **Certificate validity (days)** value.

5. Click **Self-sign and apply**.
6. The page reloads after 10 seconds, and the certificate is applied.

## System Configuration Checksum tool

This creates a checksum baseline of a specific current configuration. Administrators can use this quick tool to periodically verify if the configuration has changed.

### WebUI Procedure

1. Go to *System :: Toolkit*.
2. Click **System Configuration Checksum** icon (displays dialog).

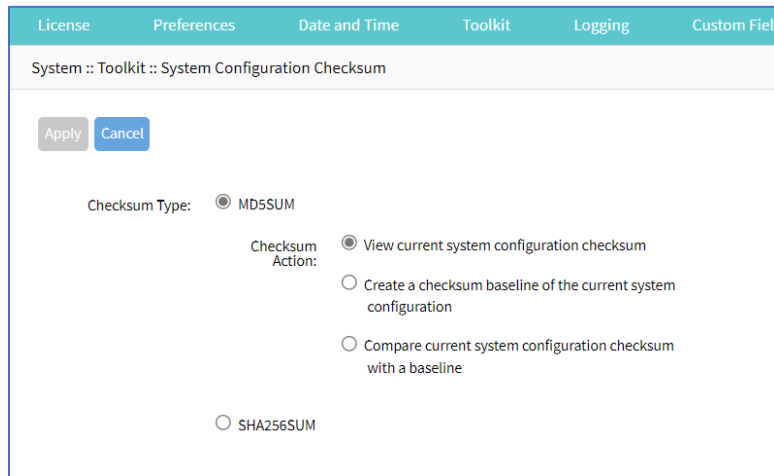

A screenshot of a web dialog box titled "System :: Toolkit :: System Configuration Checksum". At the top, there are navigation tabs: License, Preferences, Date and Time, Toolkit, Logging, and Custom Fields. Below the title bar, there are "Apply" and "Cancel" buttons. The main content area has two sections: "Checksum Type:" with radio buttons for "MD5SUM" (selected) and "SHA256SUM"; and "Checksum Action:" with radio buttons for "View current system configuration checksum" (selected), "Create a checksum baseline of the current system configuration", and "Compare current system configuration checksum with a baseline".

3. In *Checksum Type* menu, select one:

**MD5SUM** radio button.

In *Checksum Action* menu, select one:

**View current system configuration checksum** radio button.

**Create a checksum baseline of the current system configuration** radio button.

**Compare current system configuration checksum with a baseline** radio button. On **Baseline Reference** drop-down, select one.

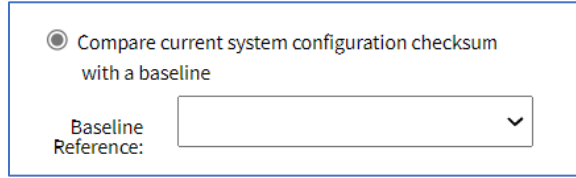

**SHA256SUM** radio button.

In *Checksum Action* menu, select one:

**View current system configuration checksum** radio button.

**Create a checksum baseline of the current system configuration** radio button.

**Compare current system configuration checksum with a baseline** radio button. On **Baseline Reference** drop-down, select one.

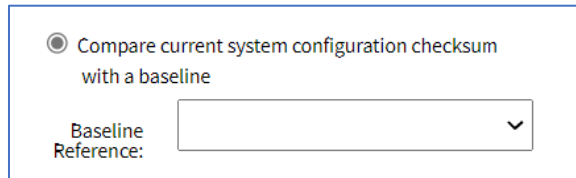

4. Click **Apply** (display results).

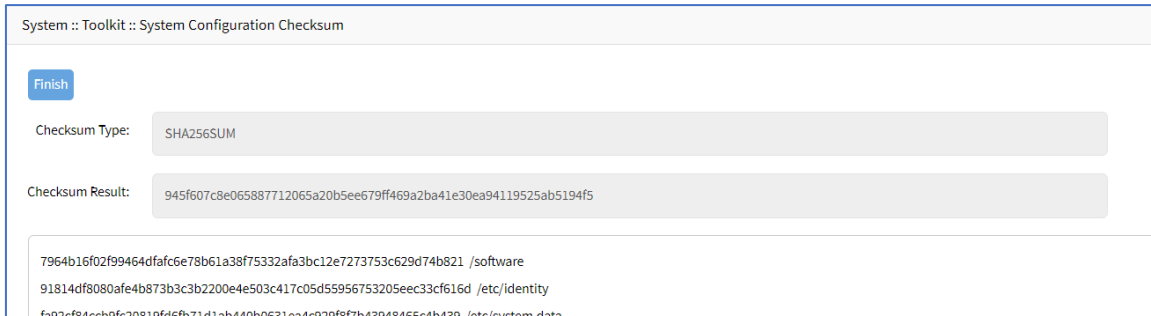

5. Review the results. If the configurations match, the main result is "Passed". If any change, altered locations are identified.

6. When done, click **Finish**.

### Network Tools tool

This provides essential network communication tools ("ping", "traceroute" and "DNS lookup"). Output is displayed in the *Command Output* panel. Displays this dialog.

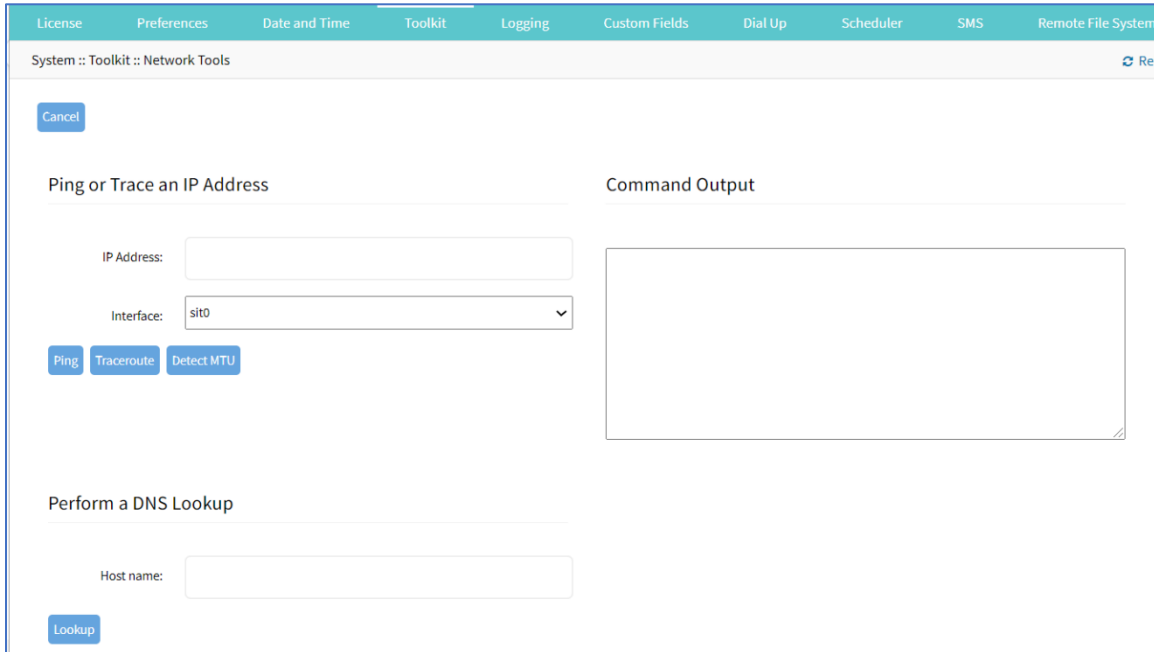

## Send a Ping

This command-line utility checks if a network device is reachable. The command sends a request over the network to a specific device. If successful, a response from the device is displayed.

### WebUI Procedure

1. Go to *System :: Toolkit*.
2. Click **Network Tools** icon (displays dialog).
3. In the *Ping or Traceroute and IP Address* menu:

Enter **IP Address**.

On **Interface** drop-down, select one (selection depends on available interfaces: **eth0**, **eth1**, **backplane0**, **backplane1**, **docker0**, **sit0**, **tap0**, **tap1**, **Source IP Address**).

Click **Ping**.

4. Review results in *Command Output* panel.

## Send a Traceroute

A traceroute sends ICMP (Internet Control Message Protocol) packets. Every router during the packet transfer is identified. This determines if the routers effectively transferred the data.

### WebUI Procedure

1. Go to *System :: Toolkit*.
2. Click **Network Tools** icon (displays dialog).
3. In the *Ping or Traceroute and IP Address* menu:

Enter **IP Address**.

On **Interface** drop-down, select one (selection depends on available interfaces: **eth0**, **eth1**, **backplane0**, **backplane1**, **docker0**, **sit0**, **tap0**, **tap1**, **Source IP Address**).

Click **Traceroute**.

- Review results in *Command Output* panel.

## Run a DNS Lookup

This process looks for the DNS record returned from a DNS server. Devices need to translate email addresses and domain names into meaningful numerical addresses.

### WebUI Procedure

- Go to *System :: Toolkit*.
- Click **Network Tools** icon (displays dialog).
- In the *Perform a DNS Lookup* menu:
  - Enter **Host name**.
  - Click **Lookup**.
- Review results in *Command Output* panel.

## Detect MTU

### WebUI Procedure

- Go to *System :: Toolkit*.
- Click **Network Tools** icon (displays dialog).
- In the *Ping or Traceroute and IP Address* menu:
  - Enter **IP Address**.

On **Interface** drop-down, select one (selection depends on available interfaces: **eth0**, **eth1**, **backplane0**, **backplane1**, **docker0**, **sit0**, **tap0**, **tap1**, **Source IP Address** – enter **Source IP Address**).

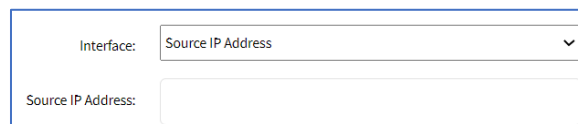

Click **Detect MTU**.

- Review results in *Command Output* panel.

## API tool

### RESTful API

The Nodegrid Platform provides an embedded RESTful API. This provides API calls to access and modify the Nodegrid device configuration. Displays this dialog.

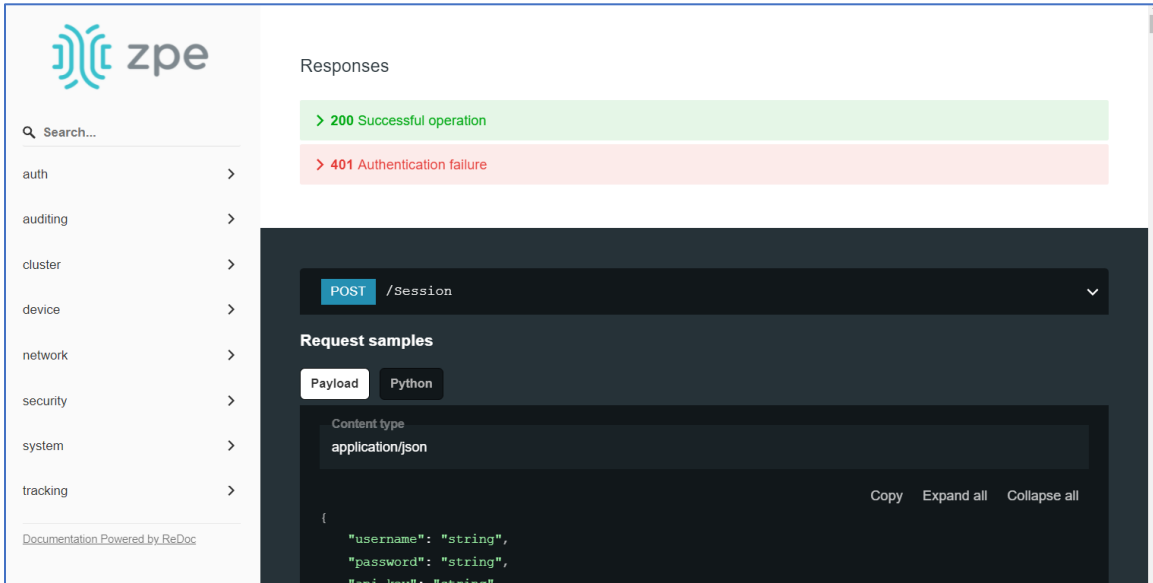

### WebUI Procedure

1. Go to *System :: Toolkit*.
2. Click on the **API** icon.

Alternatively, on Banner, **User Name** drop-down (top right), click **API Documentation**.

3. On the left panel, click the > arrow to display API calls for that function. Request and Response examples are included.

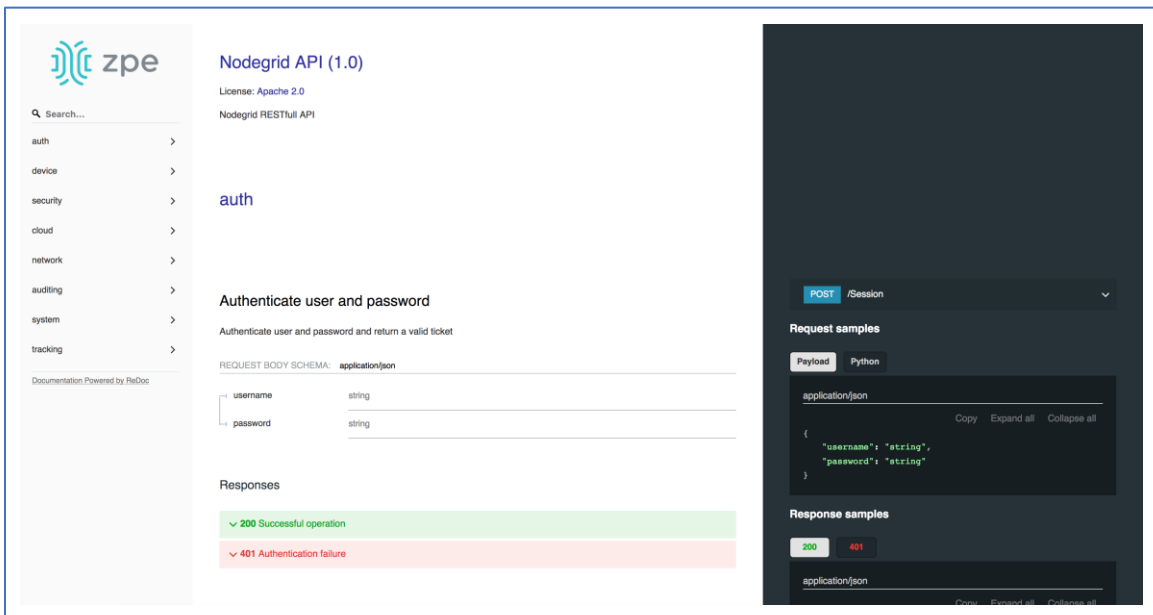

**Example: "get auditing email destination configuration"**

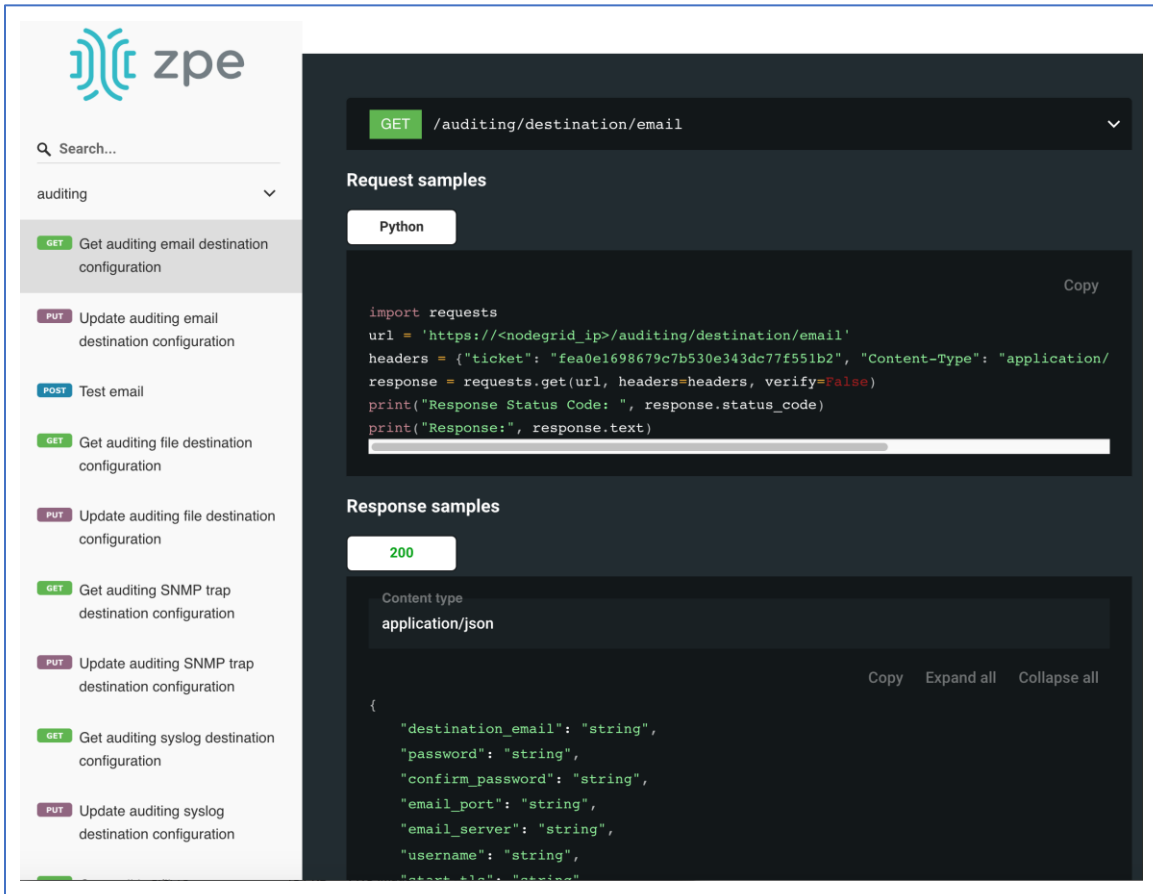

**gRPC**

The gRPC framework is supported (default: disabled). To enable gRPC:

1. Go to *Security :: .Services*.

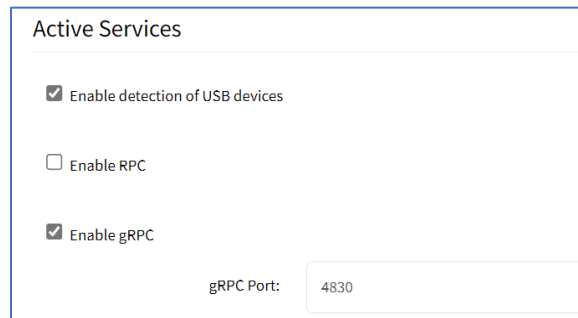

2. In *Active Services* menu:  
 Select **Enable gRPC** checkbox.  
 Enter **gRPC Port**.
3. Click **Save**.

gRPC is very scalable, performance-based RPC framework that uses simple service definitions and structured data.

There are four service definitions:

`get_request (APIRequest)` - reads data. Returns `(APIReply)`.

`post_request (APIRequest)` - executes commands or add an entry. Returns `(APIReply)`.

`put_request (APIRequest)` - executes commands that need a selected entry, or update an entry. Returns `(APIReply)`.

`delete_request (APIRequest)` - deletes existing data sets (or destroys a session. Returns `(APIReply)`.

`APIRequest` expects three arguments:

`path` - gRPC path to be used.

`ticket` - authentication ticket for the request.

`data` - structured data, in json format.

All three arguments follow the same structure as the existing REST API's. See [https://<Nodegrid IP>/api\\_doc.html](https://<Nodegrid IP>/api_doc.html) for more details.

`APIReply` returns two arguments:

`message` - structured data in json format.

`status_code` - status\_code as int32 number.

## CLI Examples

`post_request` (Authentication - returns a session ticket)

```
post_request({path: '/v1/Session', data: '{"username": "admin", "password": "admin"}'}, [...])
```

`get_request` (get network connection details)

```
get_request({path: '/v1/network/connections', ticket: 'xxxxxxxxxxxxx'}, [...])
```

`post_request` (add a phone number to the sms whitelist)

```
post_request({path: '/v1/system/sms/whitelist', ticket: 'xxxxxxxxxxxxx', data '{"name": "phone1", "phone_number": "+11111111111"}' }, [...])
```

`put_request` (update an existing value on the sms whitelist)

```
put_request({path: '/v1/system/sms/whitelist/phone1', ticket: 'xxxxxxxxxxxxx', data '{"phone_number": "+12222222222"}' }, [...])
```

`delete_request` (delete an existing value on the sms whitelist)

```
delete_request({path: '/v1/system/sms/whitelist', ticket: 'xxxxxxxxxxxxx', data
'{"whitelists": [ "phone1", "phone2" ]}' }, [...]
```

## File Manager tool

This displays the folder and file structure. To review folder contents, click on the folder name. Root (Home) folders cannot be renamed, deleted, or moved. The basic folder structure cannot be modified. This is only available to users with administrator privileges.

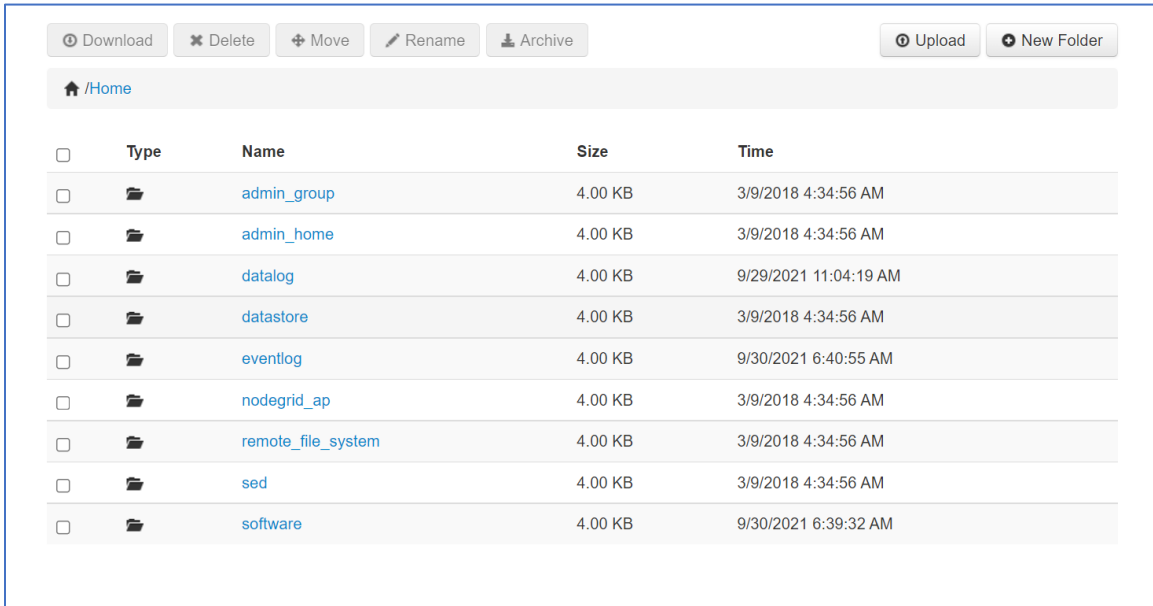

## Download File

This downloads the selected file(s) in a folder. Only files can be downloaded.

### WebUI Procedure

1. Go to *System :: Toolkit*.
2. Click **File Manager** icon (opens a new browser tab with the folder system).
3. Navigate to the folder that contains the file.
4. Select the checkbox for each file to download.
5. Click **Download**.

Alternately, click on the *File Name* to download. Repeat as needed.

## Delete File or Folder

This deletes the selected files/folders.

### WebUI Procedure

1. Go to *System :: Toolkit*.
2. Click **File Manager** icon (opens a new browser tab).



3. Go to the location.
4. Select checkbox(es).
5. Click **Delete**.

## Move File or Folder

This moves the selected folders/files to a different folder location.

### WebUI Procedure

1. Go to *System :: Toolkit*.
2. Click **File Manager** icon (opens a new browser tab).
3. Go to the location.
4. Select checkbox(es).
5. Click **Move**.
6. On the *Move* pop-up dialog, enter **Target** path.

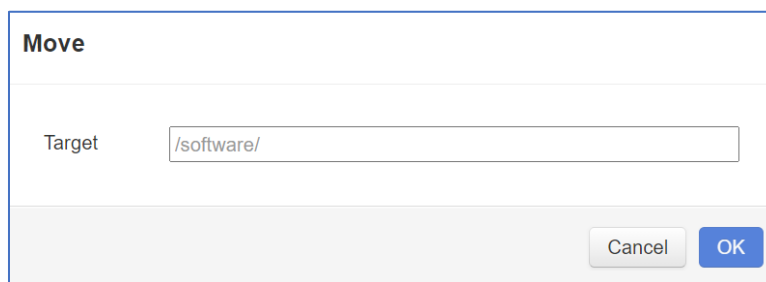

The image shows a 'Move' dialog box. It has a title bar with the word 'Move'. Below the title bar is a text input field labeled 'Target' with the text '/software/'. At the bottom right of the dialog are two buttons: 'Cancel' and 'OK'.

7. Click **OK**.

## Rename File or Folder

### WebUI Procedure

1. Go to *System :: Toolkit*.
2. Click **File Manager** icon (opens a new browser tab).
3. Go to the location.
4. Select checkbox.
5. Click **Rename**.
6. On the *Rename* pop-up dialog, enter **New Name**.

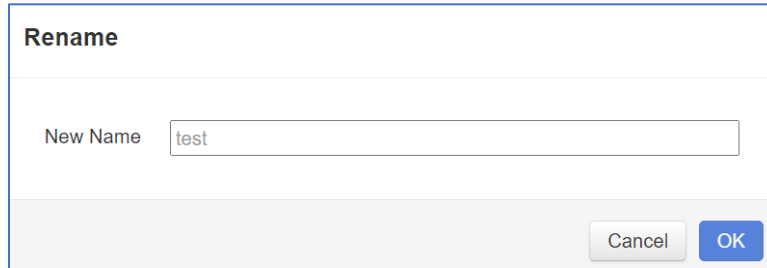

**Rename**

New Name

Cancel OK

7. Click **OK**.

### Archive File or Folder

NOTE: When a root folder is archived, it is saved in the Home directory. It cannot be deleted or moved.

#### WebUI Procedure

1. Go to *System :: Toolkit*.
2. Click **File Manager** icon (opens a new browser tab).
3. Go to the location.
4. Select checkbox(es).
5. Click **Archive**.
6. On the *Create Archive* pop-up dialog, confirm the Name (modify as needed). Select **Embed directories in archive** checkbox. Click **Create**.

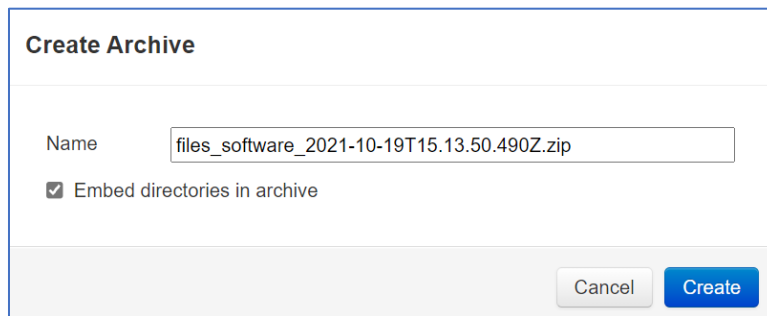

**Create Archive**

Name

Embed directories in archive

Cancel Create

The archive is saved in the same folder location. It can be renamed, moved, or downloaded, as needed.

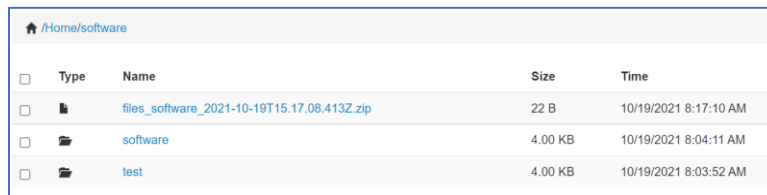

Type	Name	Size	Time
<input type="checkbox"/>	files_software_2021-10-19T15.17.08.413Z.zip	22 B	10/19/2021 8:17:10 AM
<input type="checkbox"/>	software	4.00 KB	10/19/2021 8:04:11 AM
<input type="checkbox"/>	test	4.00 KB	10/19/2021 8:03:52 AM

### Create New Folder

Cannot be done in Home location.

#### WebUI Procedure

1. Go to *System :: Toolkit*.
2. Click **File Manager** icon (opens a new browser tab).
3. Navigate to the folder location for the new folder.
4. Click **New Folder**.
5. On the *New Folder* pop-up dialog, enter **Folder Name**. Click **OK**.

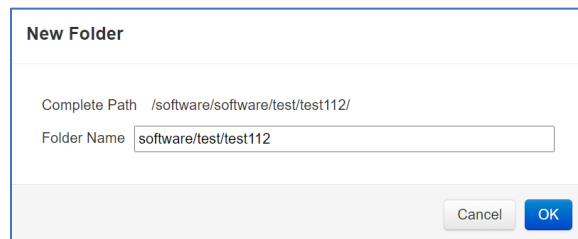

The new folder is added in that location.

## Upload File

### WebUI Procedure

1. Go to *System :: Toolkit*.
2. Click **File Manager** icon (opens a new browser tab).
3. Navigate to the folder to contain the uploaded file.
4. Click **Upload**.
5. On the *Upload File* pop-up dialog, click **Choose File**. Locate and select the file. Click **OK**.

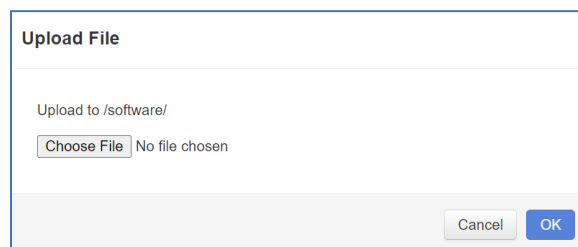

The file will upload and become available.

## Access Additional Drive(s)/Drive Partitions

If additional drives/drive partitions are mounted on the Nodegrid device, these are shown on the *File Manager* page. These locations can be used to store VMs and Docker images. This is enabled only if the additional drive is mapped as "sdb" and formatted as ext2, ext3 or ext4. See the [Create sdb Storage](#) procedure (*Applications :: Virtual Machines*) and review the *Storage pools* section.

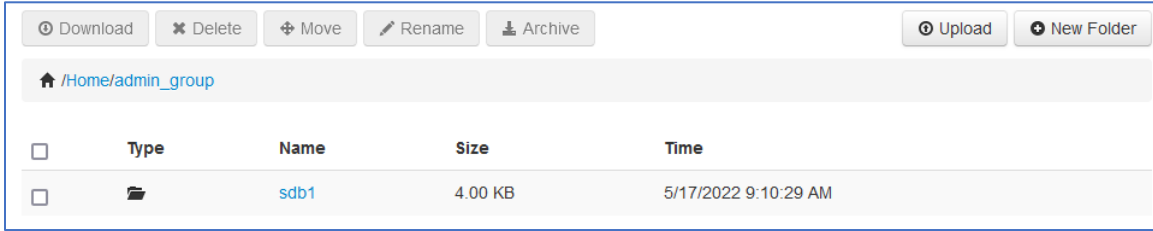

## Diagnostic Data tool

This tool creates a report on the system status of the Nodegrid device. The contents help investigate the device functionality. A series of commands output the state of the system, collect various log files, and copies the important configuration files. The output compacted file helps debug the system in case of any error or unexpected behavior.

The generated file is saved:

`/home/admin/logs/collection_nodegrid_XXXX-XX-XX_XX-XX-X.tar.gz`

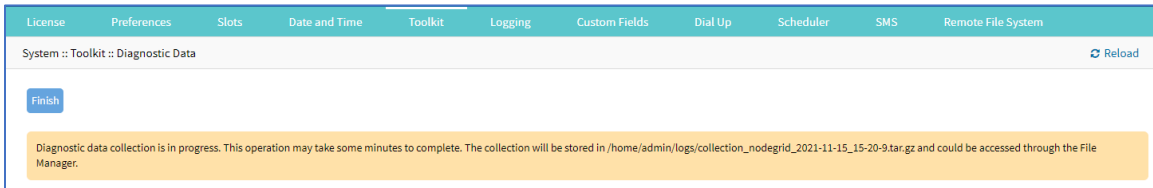

## Step 1 – Initiate Diagnostic Data

This runs the Diagnostic Data tool. The results are accessed with **File Manager**.

### WebUI Procedure

1. Go to *Systems :: Toolkit*.
2. Click **Diagnostic Data** icon.
3. The tool will run the diagnostics.
4. When done, click **Finish** (returns to the *Toolkit* page).

## Step 2 – Access the Diagnostic Data Results

(Admin privileges required.)

### WebUI Procedure

1. Go to *System :: Toolkit*.
2. Click **File Manager** icon.
3. Go to folder: **/Home/admin\_home/logs**.

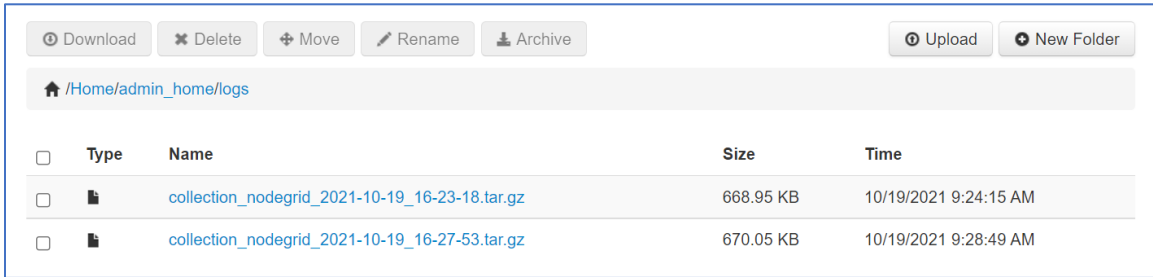

4. Locate the tarball and select checkbox.
5. Click **Download**.

Review the file, as needed.

## Cloud Enrollment tool

This allows enrollment of the device in ZPE Cloud. Displays this dialog.

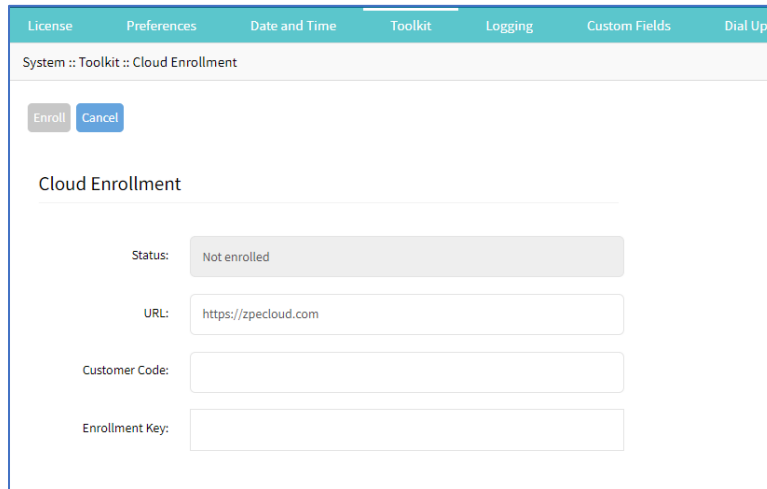

## Enable Cloud Enrollment

### WebUI Procedure

1. Go to *System :: Toolkit*.
2. Click **Cloud Enrollment** icon (displays dialog)
3. In the *Cloud Enrollment* menu:
  - Enter **URL** of the ZPE Cloud application.
  - Enter **Customer Code**.
  - Enter **Enrollment Key**.
4. Click **Save**.

## Logging tab

Data Logging is used to collect information and can also create event notifications. This is archived by defined alert strings (a simple text match or regular expression pattern string) that are evaluated against the data source stream. Events are automatically generated for each match.

Data logging can be enabled for all CLI sessions to be used for inspection and auditing. Data logs are stored locally or remotely (depending on Auditing settings).

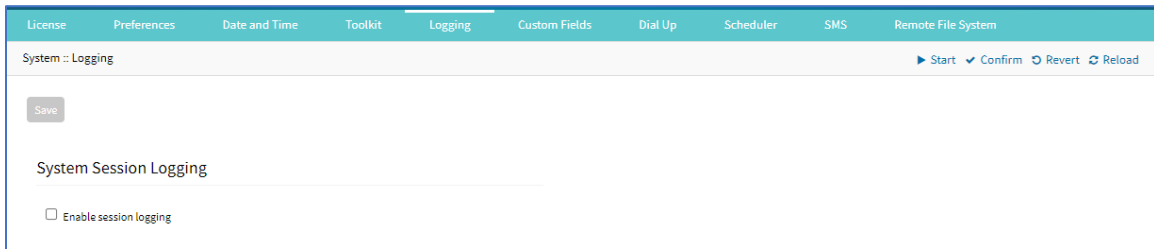

### Enable Session Logging

Details can be modified, as needed.

#### WebUI Procedure

1. Go to *System :: Logging*.
2. In *System Session Logging* menu:

Select **Enable session logging** checkbox (expands dialog).

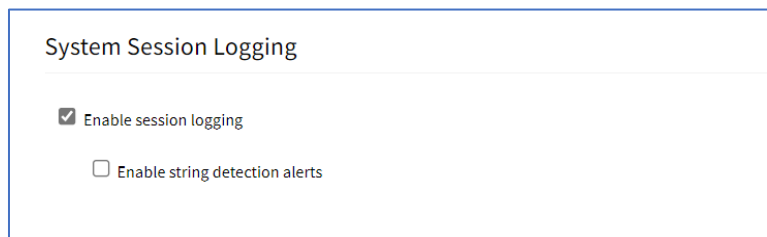

(optional) Select **Enable string detection alerts** checkbox (expands dialog). Enter **Session String** sets, as needed) that sends a notification alert upon occurrence.

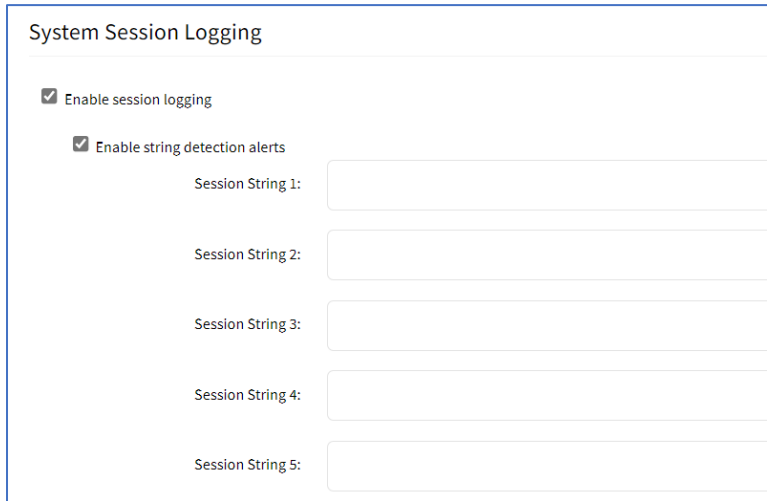

The dialog titled "System Session Logging" contains the following elements:

- Enable session logging
- Enable string detection alerts
- Session String 1:
- Session String 2:
- Session String 3:
- Session String 4:
- Session String 5:

3. Click **Save**.

## Custom Fields tab

Searchable custom fields can be created here. For example, add details not available by default. These custom fields become part of the device details.



The "System :: Custom Fields" interface shows a table with the following data:

Field Name	Field Value
example	aBC
test	1

Buttons: Add, Delete, Edit, Reload

### Add Custom Field

#### WebUI Procedure

1. Go to *System :: Custom Fields*.
2. Click **Add** (displays dialog).

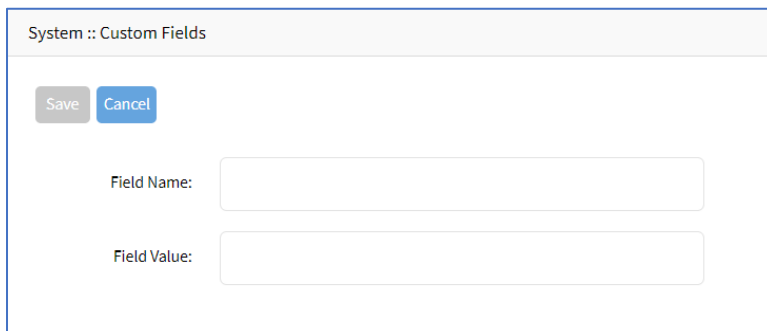

The "Add Custom Field" dialog contains the following elements:

- Buttons: Save, Cancel
- Field Name:
- Field Value:

3. Enter **Field Name**.
4. Enter **Field Value**.
5. Click **Save**.

### Edit Custom Field

#### WebUI Procedure

1. Go to *System :: Custom Fields*.
2. Select checkbox next to *Field Name*.
3. Click **Edit** (displays dialog).
4. Make changes.
5. Click **Save**.

### Delete Custom Field

#### WebUI Procedure

1. Go to *System :: Custom Fields*.
2. Select checkbox next to *Field Name*.
3. Click **Delete**.

## Dial-Up tab

Parameters for dialing to the device and callback users are configured here. Login and PPP connection features are also defined using the drop-down menu.

### Services sub-tab

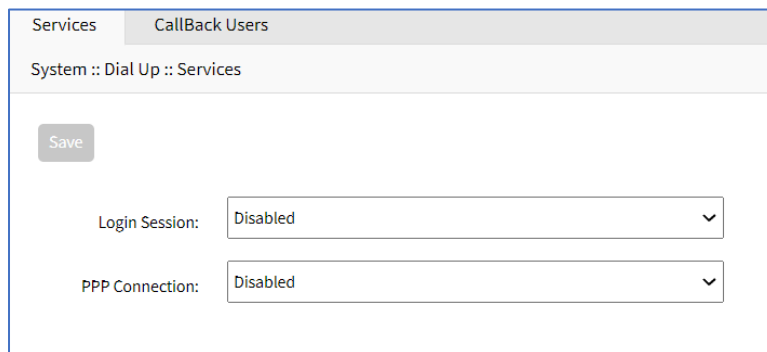

The screenshot shows a web interface for configuring dial-up services. At the top, there are two tabs: 'Services' (selected) and 'CallBack Users'. Below the tabs, the breadcrumb path is 'System :: Dial Up :: Services'. A 'Save' button is located on the left. There are two drop-down menus: 'Login Session' and 'PPP Connection', both currently set to 'Disabled'.

### Manage Dial Up Services

#### WebUI Procedure

1. Go to *System :: Dial Up :: Services*.
2. On **Login Session** drop-down, select one (**Enabled**, **Disabled**, **Callback**).



3. On **PPP Connection** drop-down, select one (**Enabled, Disabled, Callback**).
4. Click **Save**.

### Callback Users sub-tab

System :: Dial Up :: CallBack Users	
<input type="checkbox"/>	Callback User
<input type="checkbox"/>	apsjones
	Callback Number
	1-123-345-4567

### Add Callback User

#### WebUI Procedure

1. Go to *System :: Dial Up :: Callback Users*.
2. Click **Add**-(displays dialog).

System :: Dial Up :: CallBack Users	
<input type="button" value="Save"/>	<input type="button" value="Cancel"/>
Callback User:	<input type="text"/>
Callback Number:	<input type="text"/>

3. Enter **Callback User**.
4. Enter **Callback Number**.
5. Click **Save**.

### Delete Callback User

#### WebUI Procedure

1. Go to *System :: Dial Up :: Callback Users*.
2. Select checkbox next to Callback User.
3. Click **Delete**.

### Edit Callback User

#### WebUI Procedure

1. Go to *System :: Dial Up :: Callback Users*.
2. In *Callback User* column, click name.

3. On the dialog, make changes.
4. Click **Save**.

## Scheduler tab

On this tab, administrators can execute tasks and scripts on a schedule. These can be maintenance tasks or automation tasks that include end devices.

Task Name	User	Command to Execute	Task Description	Task Status
<input checked="" type="checkbox"/> test	daemon	Ctl-A	testtest	Enabled
<input type="checkbox"/> test2	daemon	Ctl-S	test`12	Disabled

The tasks must be a text file with Nodegrid CLI commands or script file located on the device. The file needs to be accessible and executable by the user.

### Scheduler Date/Time examples

Factor	Daily Task 00:01 hours	Every Saturday: 23:45 hours	Every Hour on the Hour
Minute	1	45	0
Hour	0	23	*
Day of Month	*	*	*
Month	*	*	*
Day of Week	*	6	*

## Manage Tasks

### Add a Task

#### WebUI Procedure

1. Go to *System :: Scheduler*.
2. Click **Add** (displays dialog).

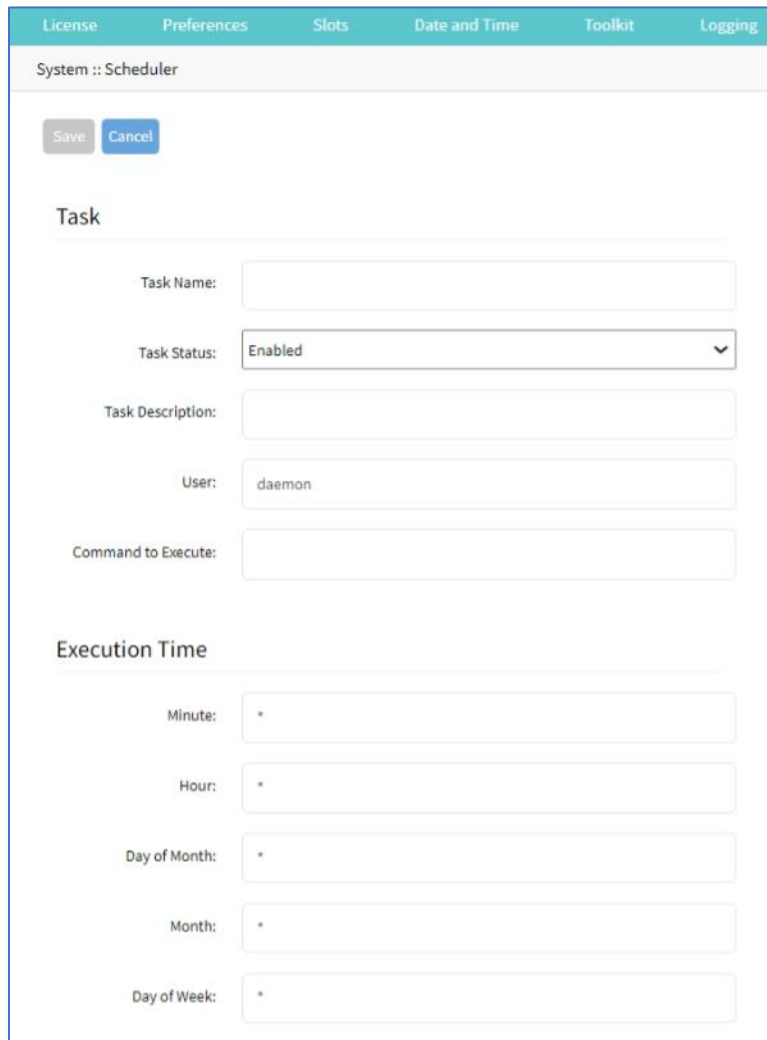

The screenshot shows a web-based dialog box titled "System :: Scheduler". At the top, there are navigation tabs: "License", "Preferences", "Slots", "Date and Time", "Toolkit", and "Logging". Below the tabs, there are "Save" and "Cancel" buttons. The dialog is divided into two main sections: "Task" and "Execution Time".

**Task Section:**

- Task Name:** An empty text input field.
- Task Status:** A dropdown menu currently showing "Enabled".
- Task Description:** An empty text input field.
- User:** A text input field containing the value "daemon".
- Command to Execute:** An empty text input field.

**Execution Time Section:**

- Minute:** A text input field containing an asterisk (\*).
- Hour:** A text input field containing an asterisk (\*).
- Day of Month:** A text input field containing an asterisk (\*).
- Month:** A text input field containing an asterisk (\*).
- Day of Week:** A text input field containing an asterisk (\*).

3. In the *Task* menu:
  - Enter **Task Name**.
  - On **Task Status** drop-down, select one (**Enabled, Disabled**).
  - (optional) Enter **Task Description**.
  - For **User**, accept default.
  - Enter **Command to Execute** (Shell command to execute).
4. In the *Execution Time* menu, modify fields as needed.
  - Minute** (\*, numbers [0 to 59], '2,3,4', '2-5', '3/12')
  - Hour** (\*, numbers [0 to 23], '0,4,8', '10-12', '4/7')
  - Day of month** (\*, numbers [1 to 31], '8,12,20', '10-20', '3/12')

**Month** (\*, numbers [Jan=1, Feb=2, ..., Dec=12], '3,6,9,12', '1-5', '2/10')

**Day of Week** (\*, numbers (Sun=0, Mon=1, ..., Sat=6), '0,4,6', '1-5', '1/4')

5. Click **Save**.

## Edit a Task

### WebUI Procedure

1. Go to *System :: Scheduler*.
2. In the *Task Name* column, click on the name (displays dialog).
3. Make changes as needed.
4. Click **Save**.

## Delete a Task

### WebUI Procedure

1. Go to *System :: Scheduler*.
2. Select checkbox next to a task.
3. Click **Delete**
4. On confirmation dialog, click **OK**.

## Clone a Task

### WebUI Procedure

1. Go to *System :: Scheduler*.
2. In the *Task Name* column, click checkbox next to the task to be cloned.
3. Click **Clone** (displays dialog).

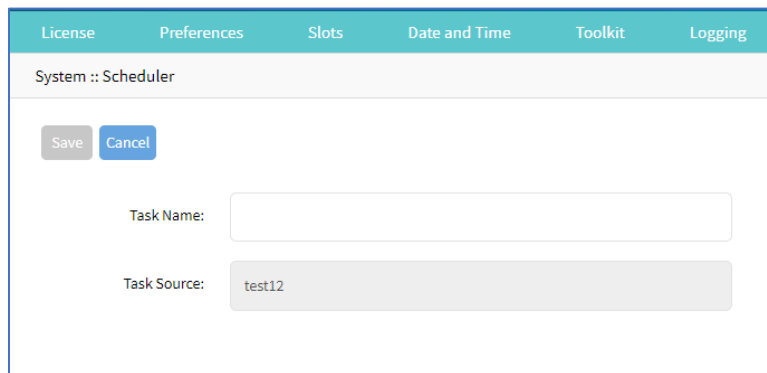

4. Enter **Task Name**.
5. Click **Save**.
6. As needed, edit the cloned task.

## Enable/Disable a Task

### Enable Task

1. Go to *System :: Scheduler*.
2. In the *Task Name* column, select checkbox of a disabled task.
3. Click **Enable**.

### Disable Task

1. Go to *System :: Scheduler*.
2. In the *Task Name* column, select checkbox of an enabled task.
3. Click **Disable** (to disable task).

## SMS tab (only with installed cellular module)

**NOTE:** This function is only available on devices on devices with the cellular module installed: Services Router, Bold SR, Gate SR, Link SR, and Hive SR (loaded with M2-Card EM7565 M2/wireless modem).

Actions can be run remotely with an SMS incoming message. The SMS message authentication must be valid. Only allowed actions are executed.

By default, Enable Actions via incoming SMS is disabled. When enabled in the default state (no password), the device accepts SMS-triggered actions from all phone numbers. MAC address of ETH0 is the default password.

**NOTE:** The SMS option requires that the SIM card and plan to be SMS-enabled. This can be checked with the service provider. It is recommended to check the costs for this service, as some actions can respond with multiple SMS.

## Settings sub-tab

### Enable Incoming SMS Actions

#### WebUI Procedure

1. Go to *System :: SMS :: Settings*.

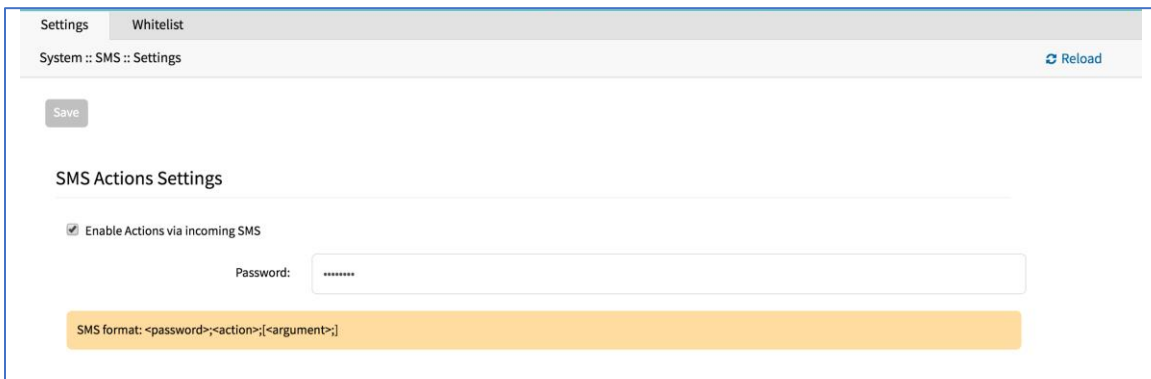

The screenshot shows the 'Settings' sub-tab for 'SMS :: Settings'. At the top, there is a 'Whitelist' tab and a 'Reload' button. Below that is a 'Save' button. The main section is titled 'SMS Actions Settings' and contains a checkbox labeled 'Enable Actions via incoming SMS' which is checked. Below the checkbox is a 'Password:' label followed by a text input field containing several asterisks. At the bottom, there is a yellow highlighted box with the text: 'SMS format: <password>-<action>-[<argument>]'.

- In *SMS Actions Settings* menu, select **Enable Actions via Incoming SMS** checkbox (displays dialog).

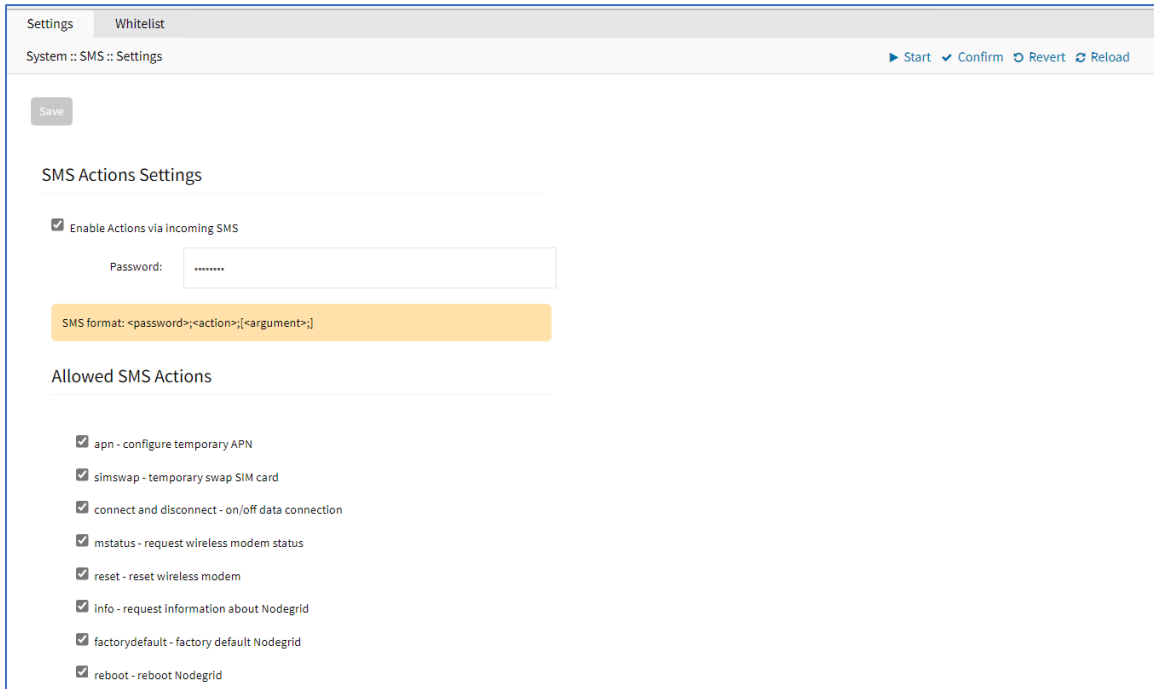

- Enter **Password**.
- In *Allowed SMS Actions* menu, select/unselect checkboxes (as needed):
  - apn - configure temporary APN** checkbox (configure a temporary APN).
  - simswap - temporary swap SIM card** checkbox (triggers a SIM card failover).
  - connect and disconnect - on/off data connection** checkbox (triggers a modem to connect or disconnect).
  - mstatus - request wireless modem status** checkbox (returns current modem status)
  - reset - reset wireless modem** checkbox (triggers a modem reset).
  - info - request information about Nodegrid** checkbox (returns *About* information).
  - factorydefault - factory default Nodegrid** checkbox (factory default of the Nodegrid device is triggered).
  - reboot - reboot Nodegrid** checkbox (triggers device reboot).
- Click **Save**.

### CLI Examples: SMS Actions and Messages

The format of SMS actions and subsequent response is given in the list below. Some actions may not require a response.

#### Format

Message format: < password >;< action >;< argument >;

Response: <response>;

apn (configure temporary APN)

```
< password >;apn;<new apn>;
```

simswap (swap sim card temporary)

```
< password >;simswap;<timeout for sim to register in secs. max 180>;  
Modem will reset to swap sim;
```

connect (try to power on data connection)

```
< password >;connect;  
Connect action started;
```

disconnect (drop current data connection)

```
< password >;disconnect;  
Disconnect action started;
```

mstatus (request modem status)

```
< password >;mstatus;  
Service:< LTE|WCDMA >;RSSI:< value dbm >;SIM:< sim number in use >;State:< status  
>;APN:< apn in use >;IP addr:< ip address when connected >
```

reset (reset wireless modem)

```
< password >;reset;  
Modem Reset will start soon;
```

info (request device information)

```
< password >;info;  
Model: < Nodegrid model >; Serial Number: < Nodegrid serial number >; Version: <  
firmware version >;
```

factorydefault (restore Nodegrid configuration to factory default)

```
< password >;factorydefault;  
Nodegrid will restore configuration to factory default and reboot;
```

reboot (reboot Nodegrid device)

```
< password >;reboot;  
Nodegrid will reboot soon;
```

## Whitelist sub-tab

On the table, administrators can add, delete, or change phone numbers which can send SMS action triggers. Requests from all other phone numbers are ignored.

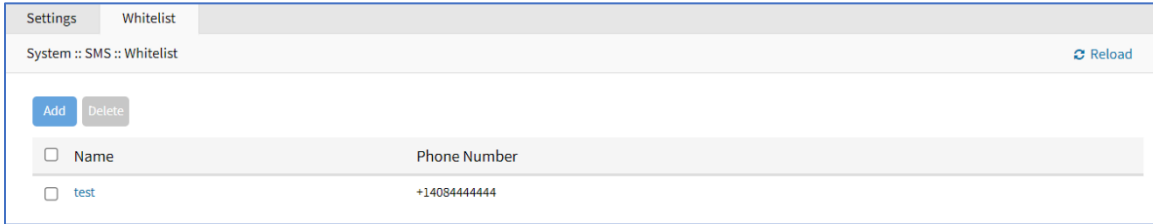

<input type="checkbox"/>	Name	Phone Number
<input type="checkbox"/>	test	+14084444444

**NOTE:** If the whitelist table is empty, requests from all phone numbers are accepted.

## Add Entry to Whitelist

### WebUI Procedure

1. Go to *System :: SMS :: Whitelist*.
2. Click **Add** (displays dialog).

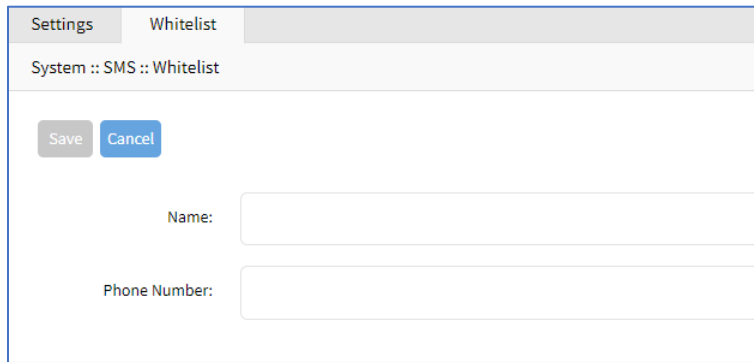

Settings | Whitelist

System :: SMS :: Whitelist

Save Cancel

Name:

Phone Number:

3. Enter **Name**.
4. Enter **Phone Number**.
5. Click **Save**.

## Remote File System tab

This designates remote file system folders.

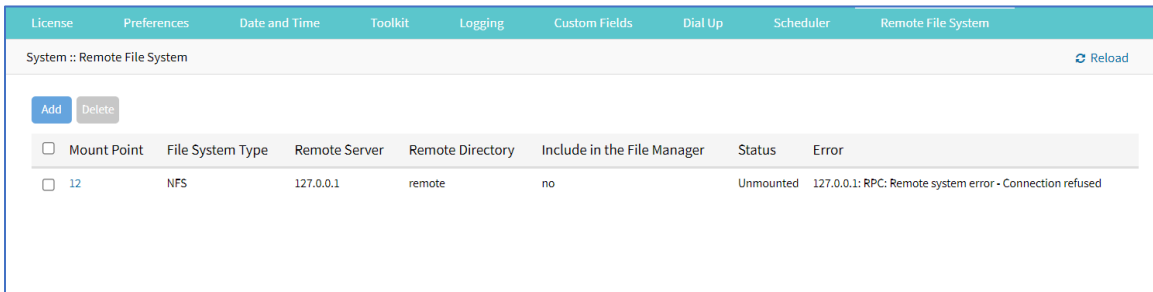

<input type="checkbox"/>	Mount Point	File System Type	Remote Server	Remote Directory	Include in the File Manager	Status	Error
<input type="checkbox"/>	12	NFS	127.0.0.1	remote	no	Unmounted	127.0.0.1: RPC: Remote system error - Connection refused



## Manage Remote File System

### Add Remote File System

#### WebUI Procedure

1. Go to *System :: Remote File System*.
2. Click **Add** (displays dialog).

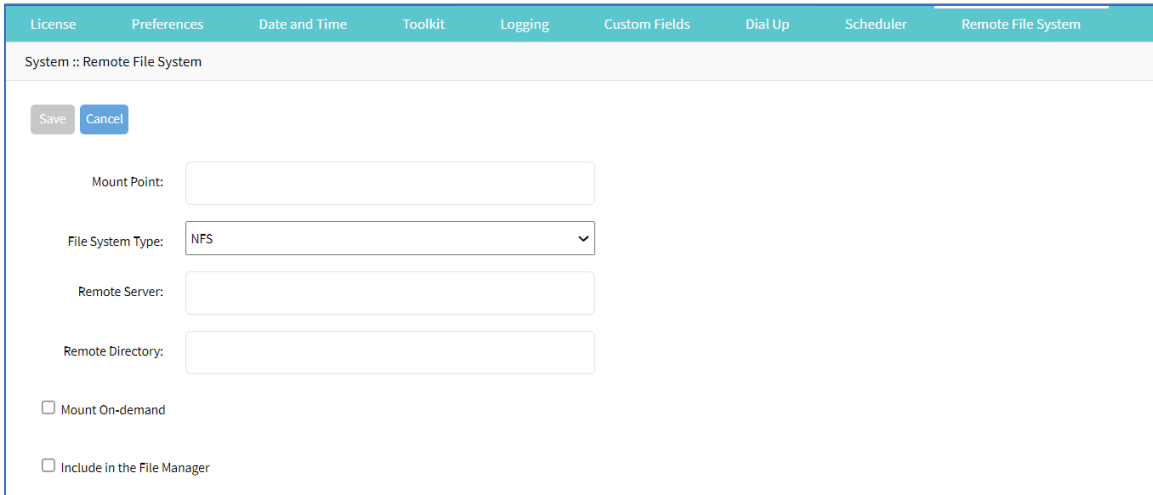

3. Enter **Mount Point**.
4. On **File System Type** drop-down, select one.

File System Type: **NFS**.

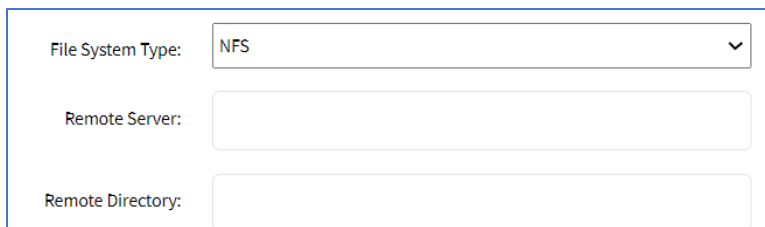

Enter **Remote Server**.

Enter **Remote Directory**.

File System Type: **Windows Sharing**.

File System Type:	Windows Sharing
Remote Server:	<input type="text"/>
Remote Directory:	<input type="text"/>
Username:	<input type="text"/>
Password:	<input type="password"/>
Confirm Password:	<input type="password"/>

Enter **Remote Server**.

Enter **Remote Directory**.

Enter **Username**.

Enter **Password** and **Confirm Password**.

File System Type: **SSHFS**

File System Type:	SSHFS
Remote Server:	<input type="text"/>
Remote Directory:	<input type="text"/>
Username:	<input type="text"/>
Authentication Method:	<input checked="" type="radio"/> Password <input type="radio"/> SSH Key
	Password: <input type="password"/> Confirm Password: <input type="password"/>

Enter **Remote Server**.

Enter **Remote Directory**.

Enter **Username**.

On *Authentication Method* menu, select one:

**Password** radio button (expands dialog). Enter **Password** and **Confirm Password**.

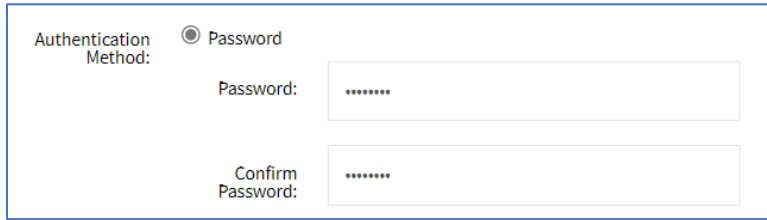

Authentication Method:  Password

Password:

Confirm Password:

**SSH Key** radio button (expands dialog). Enter **SSH Key File Path**.

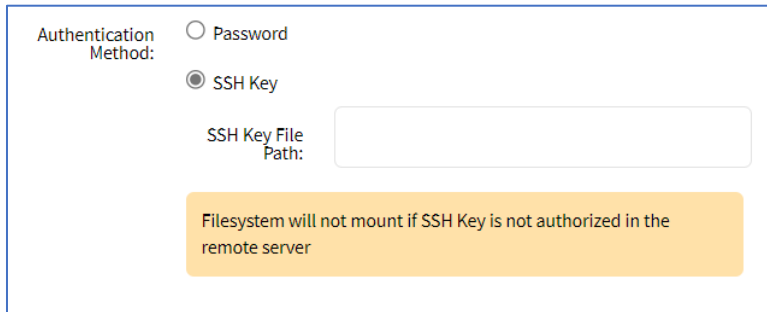

Authentication Method:  Password

SSH Key

SSH Key File Path:

Filesystem will not mount if SSH Key is not authorized in the remote server

5. (optional) Select **Mount On-demand** checkbox.
6. (optional) Select **Include in the File Manager** checkbox.
7. Click **Save**.

## Edit Remote File System

### WebUI Procedure

1. Go to *System :: Remote File System*.
2. Click on the name in the *Mount Point* column (displays dialog).

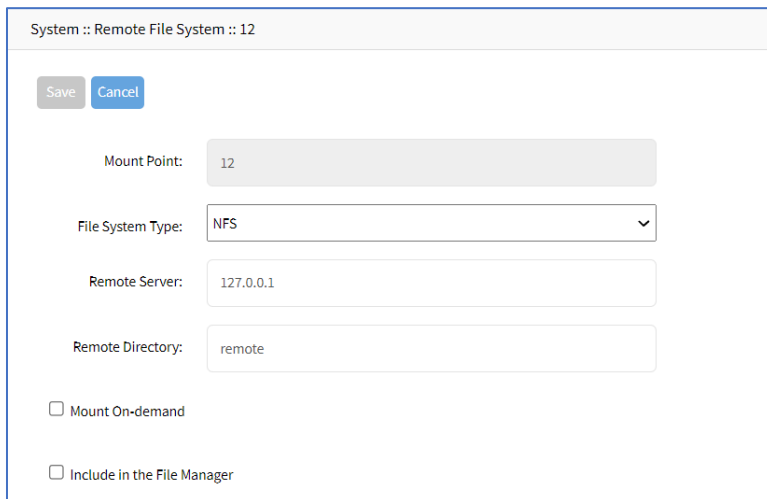

System :: Remote File System :: 12

Mount Point:

File System Type:

Remote Server:

Remote Directory:

Mount On-demand

Include in the File Manager

3. Make changes, as needed.
4. Click **Save**.

## Delete Remote File System

### WebUI Procedure

1. Go to *System :: Remote File System*.
2. Select checkbox next to name.
3. Click **Delete** (displays confirmation dialog).

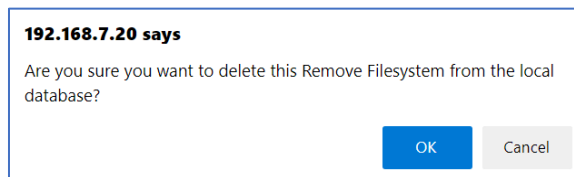

4. Click **OK**.

## I/O Ports tab (only with GPIO)

**NOTE:** This tab is displayed only if the Nodegrid device is equipped with GPIO (Digital I/O ports).

This sets the configuration of the state of digital outputs and DIO0/DIO1 as input or output. When DIO0/DIO1 is configured as output, the state can be set to Low or High.

License
Preferences
Date and Time
Toolkit
Logging
Custom Fields
Dial Up
Scheduler
SMS

I/O Ports
Remote File System

System :: I/O Ports ▶ Start ▼ Confirm ↺ Revert ↻ Reload

Save

### Digital Output OUT0

Description:

State:

### Alarm Relay

Description:

State:  Open  
 Close  
 Power Source Control

### Dry Contact DIO0

Description:

Direction:  Input  
 Output

State:

### Dry Contact DIO1

Description:

Direction:  Input  
 Output

State:

## Configure I/O Port Settings

1. In *Digital Output OUT0* menu:  
 Enter **Description**.  
 On **State** drop-down, select one (**Low**, **High**).
2. In *Alarm Relay* menu:  
 Enter **Description**.

On *State*, select one:

**Open** radio button.

**Close** radio button.

**Power Source Control** radio button.

3. In *Dry Contact DIO0* menu:

Enter **Description**.

On *Direction*, select one:

**Input** radio button

**Output** radio button

On **State** drop-down, select one (**Low, High**)

4. In *Dry Contact DIO1* menu:

Enter **Description**.

On *Direction*, select one:

**Input** radio button.

**Output** radio button.

On **State** drop-down, select one (**Low, High**).

5. Click **Save**.

## Network Section

Administrators can configure and adjust all network-related settings, including network configuration, LTE, WIFI interfaces, bounding, and VLAN details.

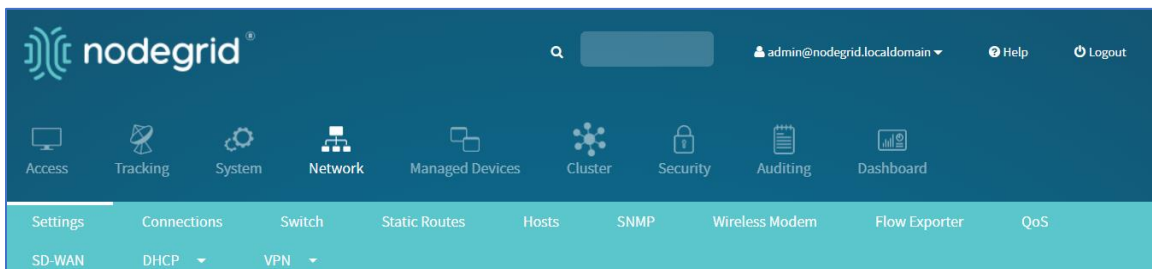

**NOTE:** Nodegrid currently supports the FRRouting suite. For more information, see <http://docs.frrouting.org/en/latest/>

## Settings tab

Administrators can define network details, including failover.

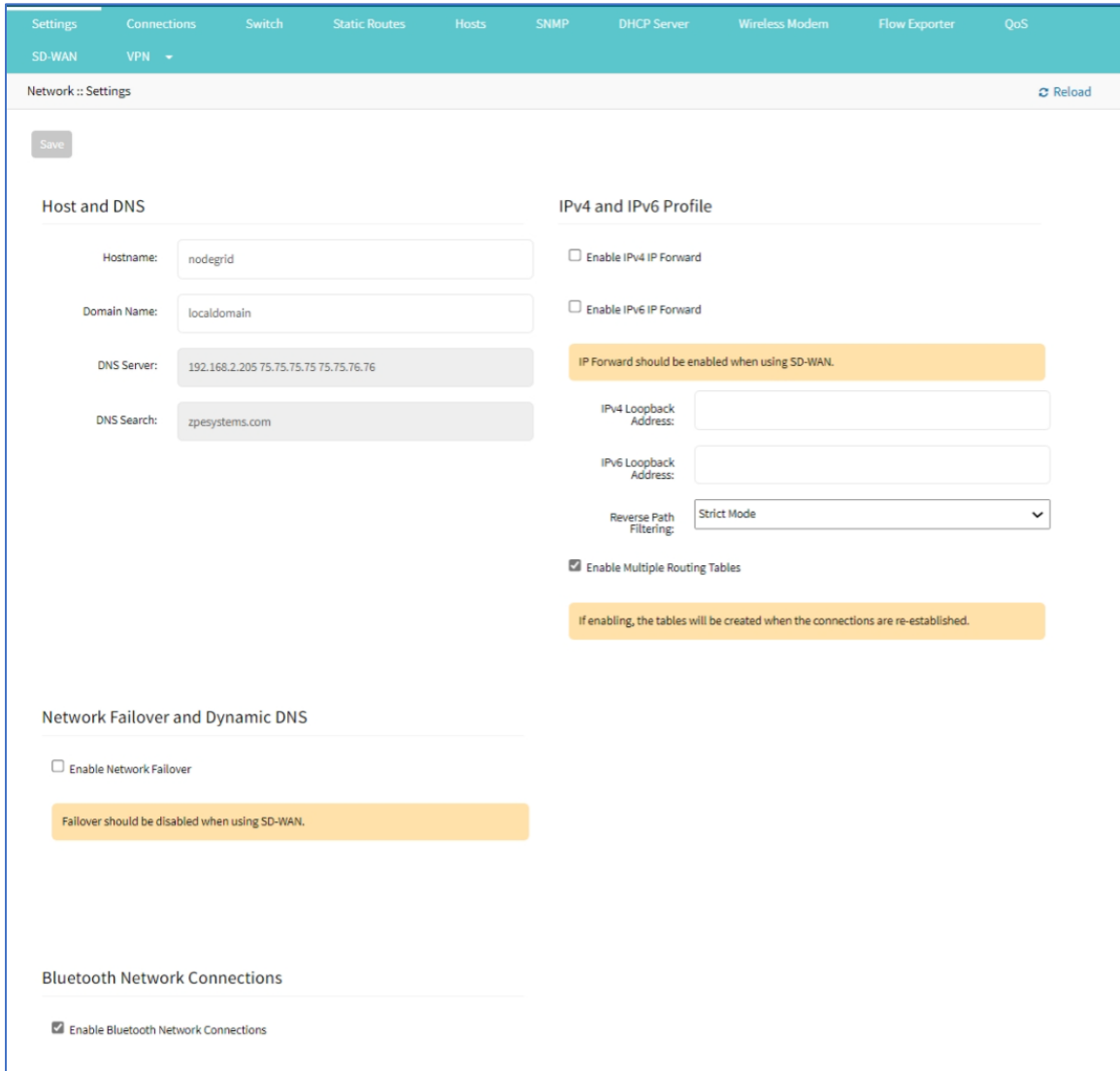

The screenshot shows the 'Network :: Settings' page with a teal header containing navigation tabs: Settings, Connections, Switch, Static Routes, Hosts, SNMP, DHCP Server, Wireless Modem, Flow Exporter, and QoS. Below the header, there are sub-tabs for 'SD-WAN' and 'VPN'. A 'Save' button is located at the top left of the settings area. The main content is divided into four sections:

- Host and DNS:** Includes input fields for Hostname (nodegrid), Domain Name (localdomain), DNS Server (192.168.2.205 75.75.75.75 75.75.76.76), and DNS Search (zpesystems.com).
- IPv4 and IPv6 Profile:** Contains checkboxes for 'Enable IPv4 IP Forward' and 'Enable IPv6 IP Forward'. A yellow warning box states 'IP Forward should be enabled when using SD-WAN.' Below are input fields for IPv4 Loopback Address and IPv6 Loopback Address, a dropdown for Reverse Path Filtering (set to Strict Mode), and a checked checkbox for 'Enable Multiple Routing Tables'. A second yellow warning box notes 'If enabling, the tables will be created when the connections are re-established.'
- Network Failover and Dynamic DNS:** Features a checkbox for 'Enable Network Failover' and a yellow warning box stating 'Failover should be disabled when using SD-WAN.'
- Bluetooth Network Connections:** Includes a checked checkbox for 'Enable Bluetooth Network Connections'.

## Manage Settings

### Configure Settings

#### WebUI Procedure

1. Go to *Network :: Settings*.
2. In the *Host & DNS* menu:
  - Enter **Hostname**.
  - Enter **Domain Name**.
  - (**DNS Server** and **DNS Search** are read-only.)
3. In *IPv4 and IPv6 Profile* menu (select one or both IP Forwards to route network traffic between network interfaces):

**IPv4 and IPv6 Profile**

---

Enable IPv4 IP Forward

Enable IPv6 IP Forward

IPv4 Loopback Address:

IPv6 Loopback Address:

Reverse Path Filtering:

Enable Multiple Routing Tables

If enabling, the tables will be created when the connections are re-established.

**NOTE:** IPv4 and IPv6 IP Forward is automatically selected if SD-WAN is enabled on the device.

Select **Enable IPv4 IP Forward** checkbox.

Select **Enable IPv6 IP Forward** checkbox.

Enter **IPv4 Loopback Address** (address is assigned a bitmask of /32).

Enter **IPv6 Loopback Address** (address is assigned a bitmask of /128).

On **Reverse Path Filtering** drop-down, select one:

**Disabled** (no source address validation is performed).

**Strict** (Each incoming packet is tested against the routing table and if the interface represents the best return path. If the packet cannot be routed or is not the best return path. it is dropped.)

**Loose** (Each incoming packet is tested only against the route table. If the packet cannot be routed, it gets dropped. This allows for asymmetric routing scenarios.)

**NOTE:** With Reverse Path Filtering, administrators can configure device behavior. By default, this is set to Strict Mode (recommended for most environments with protection against some forms of DDoS attacks). This value may need to change because of dynamic routing protocols or other network setup scenarios.

Select **Enable Multiple Routing Tables** checkbox (if selected, tables are created when connections re-established).

4. In *Network Failover and Dynamic DNS* menu:

The network failover option allows administrators to automatically failover between two and three different network interfaces.

Select **Enable Network Failover** checkbox (expands dialog).

**NOTE:** If SD-WAN is enabled, the **Enable Network Failure** checkbox is disabled.



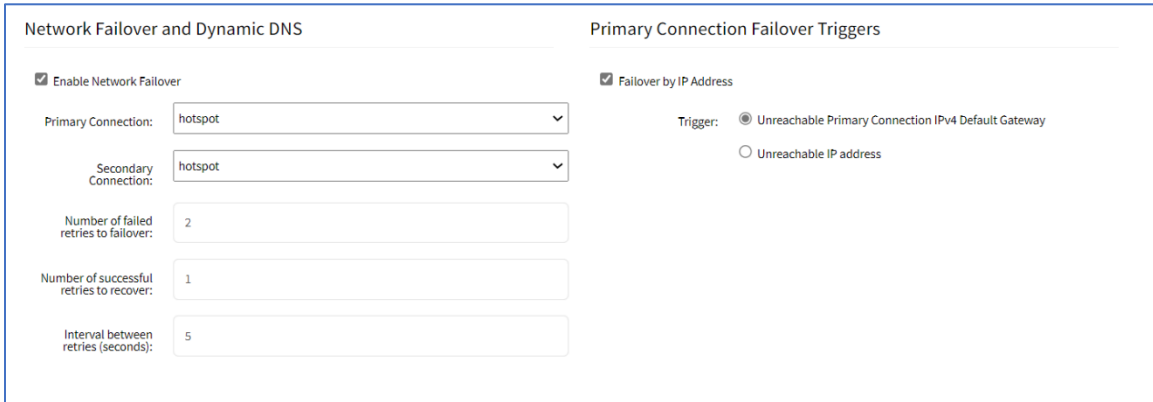

On **Primary Connection** drop-down, select one (**BACKPLANE0, BACKPLANE1, ETH0, ETH1, hotspot**).

On **Secondary Connection** drop-down, select one (**BACKPLANE0, BACKPLANE1, ETH0, ETH1, hotspot**).

Enter **Number of failed retries to failover** (default: 2).

Enter **Number of successful retries to recover** (default: 1)

Enter **Interval between retries (seconds)** (default: 5)

In *Primary Connection Failover Triggers* menu (the selection depends on type of Nodegrid device):

Select **Failover by IP Address** checkbox.



In *Trigger* menu, select one:

**Unreachable Primary Connection IPv4 Default Gateway** radio button.

**Unreachable IP address** radio button. Enter **Address**.

In *Dynamic DNS* menu, select **Enable Dynamic DNS** checkbox (displays dialog).

### Dynamic DNS

Enable Dynamic DNS

DDNS server name:

DDNS server TCP port:

ZONE:

Failover Hostname (FQDN):

Key Information for dnssec:

Username:

Algorithm:

Key Size:

Enter **DDNS server name**.

Enter **DDNS server TCP port** (default: 53).

Enter **ZONE**.

Enter **Failover Hostname (FQDN)**.

Enter **Username**.

On **Algorithm** drop-down, select one (**HMAC-MD5, HMAC-SHA1, HMAC-SHA224, HMAC-SHA256, HMAC-SHA384, HMAC-SHA512**).

Enter **Key Size** (default: 512).

**(Following displays only when wireless connections are available.)**

Select **Failover by Signal Strength** checkbox (triggered when signal strength drops below a user-defined percentage).

Failover by Signal Strength

Signal Strength (%):

Enter **Signal Strength (%)** value.

Select **Failover by Data Usage** checkbox (triggered when one of these limits are met):

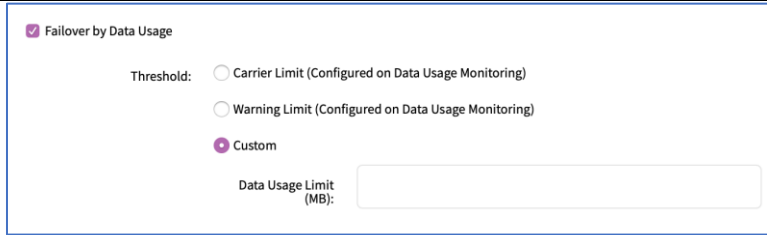

In *Threshold* menu, select one:

**Carrier Limit (Configured on Data Usage Monitoring)** radio button.

**Warning Limit (Configured on Data Usage Monitoring)** radio button.

**Custom** radio button – enter **Data Usage Limit (MB)** value.

**NOTE:** For more information on APNs, see <https://support.zpesystems.com/portal/kb/articles/what-is-the-apn-for-my-nsr-or-bsr-to-connect-to-4g-lte> for details on how to configure Carrier and Warning limits.

Select **Failover by Schedule** checkbox (triggers on a set schedule).

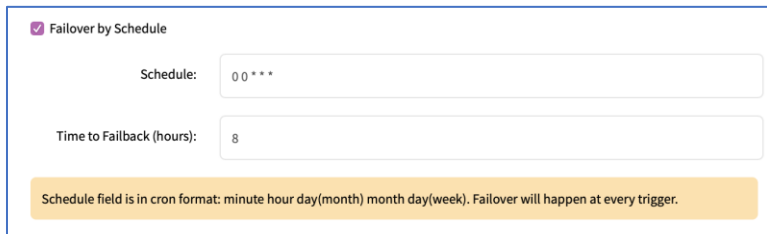

Enter **Schedule** value

(# # # # #, separated by word space) Sequence: *minute* (0-59), *hour* (0-23), *day of month* (0-30), *month* (0-11), *day of week* (0-6).

Enter **Time to Failback (hours)** value.

5. In *Blue Tooth Network Connections* (applies only if Bluetooth is enabled):

Select **Enable Bluetooth Network Connections** checkbox.

6. Click **Save**.

## Connections tab

Administrators can edit, add, and delete existing network configurations. All existing physical interfaces are automatically added.

Network :: Connections									
Name	Status	Type	Interface	Carrier State	IPv4 Address	IPv6 Address	MAC Address	Description	
BACKPLANE0	Not Active	Ethernet	backplane0	Up			00:90:fb:63:40:62		
ETH0	Connected	Ethernet	eth0	Up	192.168.7.25/24	fe80::290:fbff:fe63:4063/64	00:90:fb:63:40:63		
hotspot	Not Active	WiFi		Down					

## Manage Network Connections

### Edit Network Connection

This applies to all connections, except hotspot.

1. Go to *Network :: Connections*.
2. In the *Name* column, click on the connection to be edited.
3. Make changes, as needed.
4. Click **Save**.

### Configure hotspot Network Connection

1. Go to *Network :: Connections*.
2. In the *Name* column, click **hotspot** (displays dialog).

Network :: Connections :: hotspot

Save Cancel

Name:

Type:

Description:

Connect Automatically

Set as Primary Connection

Enable LLDP advertising and reception through this connection

Block Unsolicited Incoming Packets

**WiFi Connection**

WiFi SSID:

WiFi Security:  WPA2 Personal

WPA shared key:

WPA2 Enterprise

IPv4 Mode:  No IPv4 Address

Server (shared interface to others)

IP Address:

BitMask:

IPv6 Mode:  No IPv6 Address

DHCPv6 Prefix Delegation

- As needed, modify details:

Enter/modify **Description**.

Select **Connect Automatically** checkbox.

Select **Set as Primary Connection** checkbox.

Select **Enable LLDP advertising and reception** checkbox (expands dialog) .

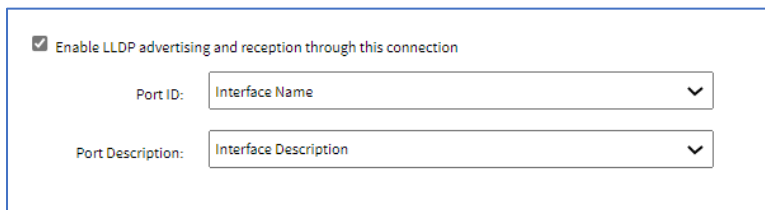

On **Port ID** drop-down, select one.

On **Port Description** drop-down, select one.

Select **Unsolicited Incoming Packets** checkbox.

- In *WiFi Connection* menu:

Enter **WiFi SSID**.

In *WiFi Security* menu, select one:

**Disabled** radio button.

**WPA2 Personal** radio button.

Enter **WPA shared key**.

**WPA2 Enterprise** radio button.

On **Region** drop-down, select one (00 applies globally) .

On *WiFi Band* menu, select one:

**2.4 GHz** radio button.

**5 GHz** radio button.

- In *IPv4 Mode* menu, select one:

**No IPv4 Address** radio button.

**Server (shared interface to others)** radio button.

Enter **IP Address**.

Enter **BitMask**.

- In *IPv6 Mode* menu, select one:

**No IPv6 Address** radio button.

**DHCPv6 Prefix Delegation** radio button.

7. Click **Save**.

## Delete Network Connection

### WebUI Procedure

1. Go to *Network :: Connections*.
2. Select a connection checkbox.
3. Click **Delete**.

## Move Connection Carrier State Up or Down

### WebUI Procedure

1. Go to *Network :: Connections*.
2. Select a connection checkbox.
3. To make it active, click **Up**.
4. To make it inactive, click **Down**.

## Set Device to be a WiFi Client

To use the device as a WiFi client, the existing hotspot connection must be disabled (make sure Carrier State is Down).

### WebUI Procedure

1. Go to *Network :: Connections*.
2. In the *Name* column, click on hotspot connection.
3. Unselect the **Connect Automatically** checkbox.
4. Click **Save**.
5. On the table, verify the hotspot interface is down.
6. The system creates a new WiFi interface to allow the device to act as a client.

## Create Interface Connections

### Add Bonding Interface

With bonding interfaces, the system can bond two physical network interfaces to one interface. All physical interfaces in the bond act as one interface. This allows for an active failover between the two interfaces if an interface physical connection is interrupted.

The built-in Network Failover can do the same. The main difference is that the built-in feature Network Failover works on the IP layer for more functionality. A bonding interface works on the link layer.

**NOTE:** The build function Network Failover and Bonding can be combined.

For the bonding interface, the administrator can define normal network settings (IP address, bitmask, and other settings).

**WebUI Procedure**

1. Go to *Network :: Connections*.
2. Click **Add** (displays dialog).
3. Enter **Name**.
4. On **Type** drop-down, select **Bonding**.

Network :: Connections

Save
Cancel

Name:

Type:

Description:

Connect Automatically

Set as Primary Connection

Enable LLDP advertising and reception through this connection

Block Unsolicited Incoming Packets

**Bonding Connection**

Bonding Mode:

Primary Interface:

Secondary Interface:

Link Monitoring:

Monitoring Frequency (ms):

Link Up delay (ms):

Link Down delay (ms):

Bond Fail-over-MAC policy:

IPv4 Mode:  No IPv4 Address  
 DHCP  
 Static

IPv4 DNS Server:

IPv4 DNS Search:

IPv4 Default Route Metric:

Ignore obtained IPv4 Default Gateway

Ignore obtained DNS server

IPv6 Mode:  No IPv6 Address  
 Link-local Only  
 Address Auto Configuration  
 Stateful DHCPv6  
 Static

IPv6 DNS Server:

IPv6 DNS Search:

IPv6 Default Route Metric:

Ignore obtained IPv6 Default Gateway

Ignore obtained DNS server

5. Enter **Description**.
6. Select **Connect Automatically** checkbox (connection is automatically established at startup).
7. Select **Set as Primary Connection** (defines interface as the primary connection. Only one interface can be the primary.)
8. Select **Enable LLDP advertising and reception through this connection** checkbox.

Enable LLDP advertising and reception through this connection

Port ID:

Port Description:

On **Port ID** drop-down, select one (Interface Name, Interface Index).

On **Port Description** drop-down, select one (Interface Description, Interface Name).

9. Select **Block Unsolicited Incoming Packets** checkbox.

10. In *Bonding Connection* menu

On **Bonding Mode** drop-down selection, select one (**Round-robin, Active backup, XOR load balancing, Broadcast, S02.3ad(LACP), Adaptive Transmit load balancing, Adaptive load balancing**).

**Round-robin** (packets transmitted in sequential order from first available slave through the last)

Enter **Slave(s)** interface (comma separated).

On **Link Monitoring** drop-down, select one (**MII, ARP**).

Enter **Monitoring Frequency (ms)** value (MII only).

Enter **Link Up delay (ms)** value (MII only).

Enter **Link Down delay (ms)** value (MII only).

On **Bond Fail-over-MAC policy** drop-down, select one (**Primary Interface, Current Active Interface, Follow Active Interface**).

**Active backup** (Only one slave in the bond is active. A different slave becomes active if, and only if, the active slave fails.)

On **Primary Interface** drop-down, select interface.

On **Secondary Interface** drop-down, select interface.

On **Link Monitoring** drop-down, select one (**MII, ARP**).

Enter **Monitoring Frequency (ms)** value (MII only).

Enter **Link Up delay (ms)** value (MII only).

Enter **Link Down delay (ms)** value (MII only).

On **Bond Fail-over-MAC policy** drop-down, select one (**Primary Interface, Current Active Interface, Follow Active Interface**).

**XOR load balancing** (Transmit based on the selected transmit hash policy.)

Enter **Slave(s)** interface (comma separated).

On **Link Monitoring** drop-down, select one (**MII, ARP**).

Enter **Monitoring Frequency (ms)** value (MII only).



Enter **Link Up delay (ms)** value (MII only).

Enter **Link Down delay (ms)** value (MII only).

On **Bond Fail-over-MAC policy** drop-down, select one (**Primary Interface, Current Active Interface, Follow Active Interface**).

On **Transmit Hash Policy** drop-down, select one (**Layer 2, Layer 2 and 3, Layer 3 and 4, Layer 2 and 3 and Encap, Layer 3 and 4 and Encap**)

**Broadcast** (Transmits everything on all slave interfaces. This mode provides fault tolerances.)

Enter **Slave(s)** interface (comma separated).

On **Link Monitoring** drop-down, select one (**MII, ARP**).

Enter **Monitoring Frequency (ms)** value (MII only).

Enter **Link Up delay (ms)** value (MII only).

Enter **Link Down delay (ms)** value (MII only).

On **Bond Fail-over-MAC policy** drop-down, select one (**Primary Interface, Current Active Interface, Follow Active Interface**).

**802.3ad(LACP)** (IEEE 802.3ad Dynamic link aggregation. Creates aggregation groups that share the same speed and duplex settings. Utilizes all slaves in the active aggregator according to the 802.3ad specification. Slave selection for outgoing traffic is done according to the transmit hash policy.)

Enter **Slave(s)** interface (comma separated).

On **Link Monitoring** drop-down, select one (**MII, ARP**).

Enter **Monitoring Frequency (ms)** value (MII only).

Enter **Link Up delay (ms)** value (MII only).

Enter **Link Down delay (ms)** value (MII only).

On **Bond Fail-over-MAC policy** drop-down, select one (**Primary Interface, Current Active Interface, Follow Active Interface**).

Enter **System Priority** value.

Enter **Actor MAC address**.

Enter **User Port Key**.

On **LACP rate** drop-down, select one (**Slow, Fast**).

On **Aggregation Selection Logic** drop-down, select one (**Stable, Bandwidth, Count**).

On **Transmit Hash Policy** drop-down, select one (**Layer 2, Layer 2 and 3, Layer 3 and 4, Layer 2 and 3 and Encap, Layer 3 and 4 and Encap**)

**Adaptive Transmit load balancing** (Channel bonding that does not require any special switch support. Outgoing traffic is distributed according to the current load (computed relative to the speed) on each slave. Incoming traffic is received by the current slave.)

Enter **Slave(s)** interface (comma separated).

On **Link Monitoring** drop-down, select one (**MII, ARP**).

Enter **Monitoring Frequency (ms)** value (MII only).

Enter **Link Up delay (ms)** value (MII only).

Enter **Link Down delay (ms)** value (MII only).

On **Bond Fail-over-MAC policy** drop-down, select one (**Primary Interface, Current Active Interface, Follow Active Interface**).

On **Transmit Hash Policy** drop-down, select one (**Layer 2, Layer 2 and 3, Layer 3 and 4, Layer 2 and 3 and Encap, Layer 3 and 4 and Encap**)

**Adaptive load balancing** (Includes balance-TLB plus receive load balancing - RLB for IPV4 traffic. Does not require any special switch support. Receive load balancing is achieved by ARP negotiation.)

Enter **Slave(s)** interface (comma separated).

On **Link Monitoring** drop-down, select one (**MII, ARP**).

Enter **Monitoring Frequency (ms)** value (MII only).

Enter **Link Up delay (ms)** value (MII only).

Enter **Link Down delay (ms)** value (MII only).

On **Bond Fail-over-MAC policy** drop-down, select one (**Primary Interface, Current Active Interface, Follow Active Interface**).

11. In *IPv4 Mode* menu:

**No IPv4 Address** radio button.

**DHCP** radio button.

**Static** radio button (if selected, expands dialog).

Enter **IP Address**.

Enter **BitMask**.

(optional) Enter **Gateway IP**:

(optional) Enter **IPv4 DNS Server**.

Enter **IPv4 DNS Search** (defines a domain name for DNS lookups).

Enter **IPv4 Default Route Metric**.

Select **Ignore obtained IPv4 Default Gateway** checkbox.

Select **Ignore obtained DNS server** checkbox.

12. In *IPv6 Mode* menu:

**No IPv6 Address** radio button

**Link local Only** radio button.

**Address Auto Configuration** radio button.

**Stateful DHCPv6** radio button.

**Static** radio button (if selected, display menu):

Enter **IP Address**.

Enter **Prefix Length**.

(optional) Enter **Gateway IP**.

(optional) Enter **IPv6 DNS Server**.

Enter **IPv6 DNS Search** (defines domain name for DNS lookups).

Enter **IPv6 Default Route Metric**.

Select **Ignore obtained IPv6 Default Gateway** checkbox.

Select **Ignore obtained DNS server** checkbox.

13. Click **Save**.

## Add Ethernet Interface

Additional Ethernet interfaces can be added and configured when an additional physical interface is added. This can occur during a Nodegrid Manager installation, where the System might have more than two interfaces to better support network separation.

### WebUI Procedure

1. Go to *Network :: Connections*.
2. Click **Add** (displays dialog).
3. Enter **Name**.
4. On **Type** drop-down, select **Ethernet**.

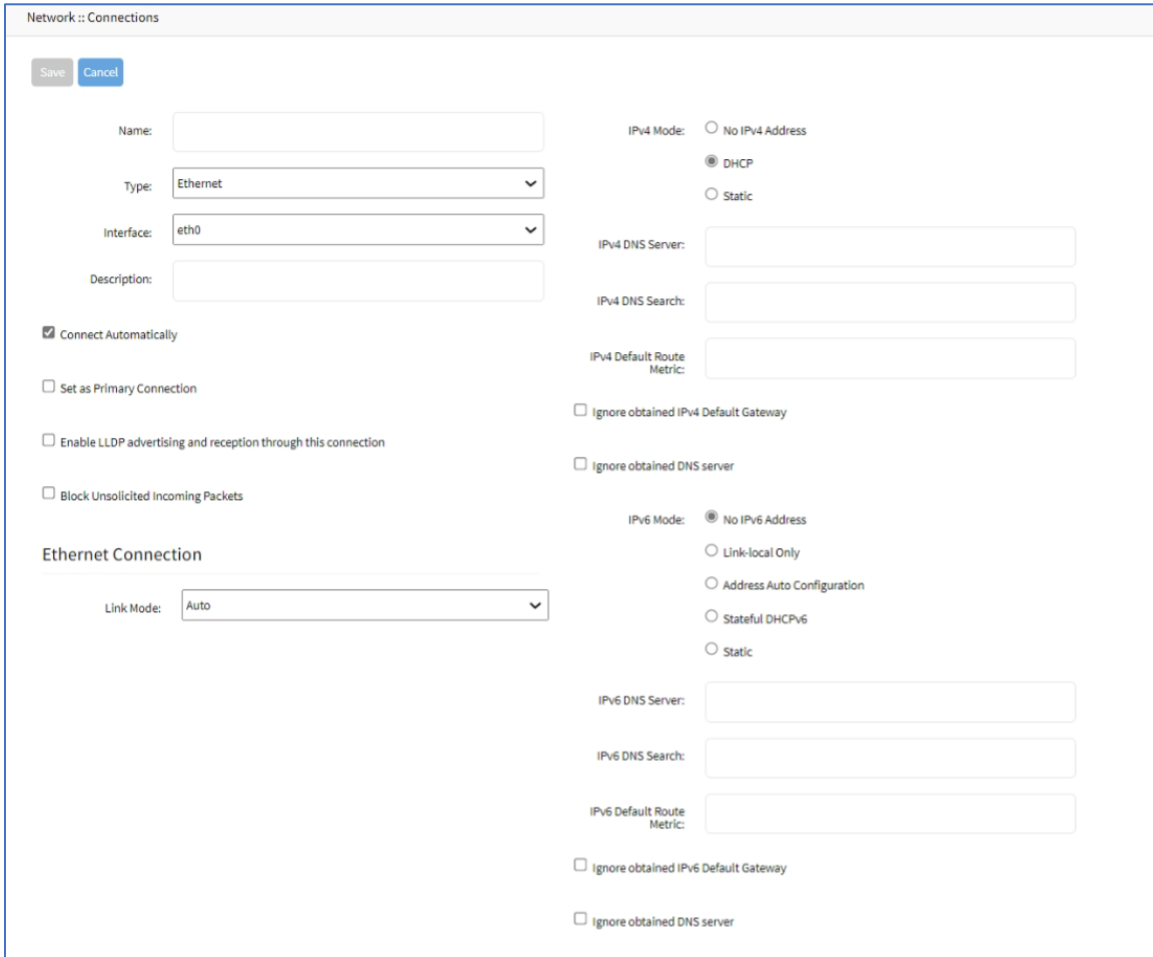

5. On **Interface** drop-down, select one.
6. Enter **Description**.
7. Select **Connect Automatically** checkbox (connection is automatically established at startup).
8. Select **Set as Primary Connection** (defines interface as the primary connection. Only one interface can be the primary.)
9. Select **Enable LLDP advertising and reception through this connection** checkbox.

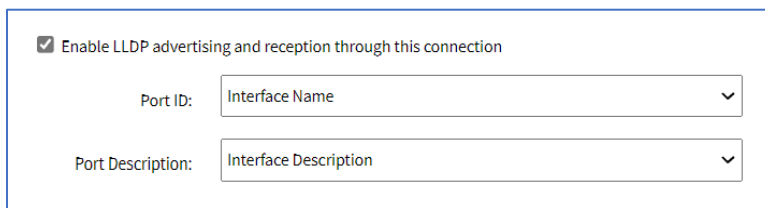

On **Port ID** drop-down, select one (**Interface Name, Interface Index**).

On **Port Description** drop-down, select one (**Interface Description, Interface Name**).

10. Select **Block Unsolicited Incoming Packets** checkbox.
11. In *Ethernet Connection* menu (availability depends on device):

On **Link Mode** drop-down, select one (selection depends on device configuration).

**NOTE:** Only available for copper interfaces. If one of these speeds is selected (not Auto), auto-negotiation (autoneg) is set to off. The selected speed/duplex becomes the default.

Select **Enable IP Passthrough** (expands menu).

On **Ethernet Connection** drop-down, select one (**ETH0, BACKPLANE0, hotspot**).

Enter **MAC Address**.

Enter **Port Intercepts**.

12. In *IPv4 Mode* menu:

**No IPv4 Address** radio button.

**DHCP** radio button.

**Static** radio button (if selected, displays menu):

Enter **IP Address**.

Enter **BitMask**.

(optional) Enter **Gateway IP**.

(optional) Enter **IPv4 DNS Server**.

Enter **IPv4 DNS Search** (defines a domain name for DNS lookups).

Enter **IPv4 Default Route Metric**.

Select **Ignore obtained IPv4 Default Gateway** checkbox.

Select **Ignore obtained DNS server** checkbox.

13. In *IPv6 Mode* menu:

**No IPv6 Address** radio button.

**Link local Only** radio button.

**Address Auto Configuration** radio button.

**Stateful DHCPv6** radio button.

**Static** radio button (if selected, displays menu):

Enter **IP Address**.

Enter **Prefix Length**.

(optional) Enter **Gateway IP**.

(optional) Enter **IPv6 DNS Server**.

Enter **IPv6 DNS Search** (defines a domain name for DNS lookups).

Enter **IPv6 Default Route Metric**.

Select **Ignore obtained IPv6 Default Gateway** checkbox.

Select **Ignore obtained DNS server** checkbox.

14. Click **Save**.

### Add Mobile Broadband GSM Interface

Mobile Broadband interfaces can be configured when a mobile broadband modem is available to the device. The Nodegrid SR family (NSR, GSR, BSR, LSR, HSR) support built-in modems available as optional add-ons. For all other units, external modems can be used.

The created interfaces allow the system to establish an Internet connection most used for failover options. Users and remote systems can directly access the device through a mobile connection (if supported by the ISP).

**NOTE:** Built-in modems support Active-Passive SIM failover. SIM-2 settings are only supported for the built-in modems.

An APN (provided by the carrier) is required for all cellular connections. For more information on APNs, see <https://support.zpesystems.com/portal/kb/articles/what-is-the-apn-for-my-nsr-or-bsr-to-connect-to-4g-lte>.

#### WebUI Procedure

1. Go to *Network :: Connections*.
2. Click **Add** (displays dialog).
3. Enter **Name**.
4. On **Type** drop-down, select **Mobile Broadband GSM**.

Network :: Connections

Name:

Type:

Interface:

Description:

Connect Automatically

Set as Primary Connection

Enable LLDP advertising and reception through this connection

Block Unsolicited Incoming Packets

Enable Connection Health Monitoring

IPv4 Mode:  No IPv4 Address  
 DHCP

IPv4 DNS Server:

IPv4 DNS Search:

IPv4 Default Route Metric:

Ignore obtained IPv4 Default Gateway

Ignore obtained DNS server

IPv6 Mode:  No IPv6 Address  
 Address Auto Configuration

IPv6 DNS Server:

IPv6 DNS Search:

IPv6 Default Route Metric:

Ignore obtained IPv6 Default Gateway

Ignore obtained DNS server

**Mobile Broadband Connection**

SIM-1 Phone Number:

SIM-1 User name:

SIM-1 Password:

SIM-1 Access Point Name (APN):

SIM-1 Personal Identification Number (PIN):

SIM-1 MTU:

Enable Data Usage Monitoring

Enable IP Passthrough

Enable Global Positioning System (GPS)

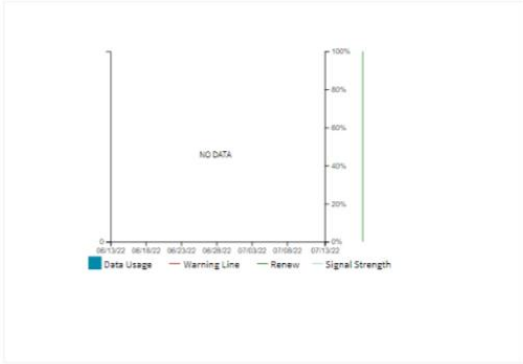

5. On **Interface** drop-down, select one.
6. Enter **Description**.
7. Select **Connect Automatically** checkbox (connection is automatically established at startup).
8. Select **Set as Primary Connection** (defines interface as the primary connection. Only one interface can be the primary.)
9. Select **Enable LLDP advertising and reception through this connection** checkbox.

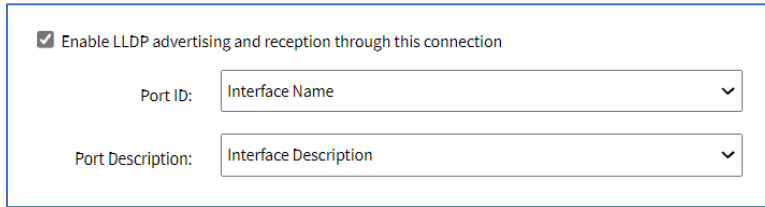

Enable LLDP advertising and reception through this connection  
 Port ID:   
 Port Description:

On **Port ID** drop-down, select one (**Interface Name, Interface Index**).

On **Port Description** drop-down, select one (**Interface Description, Interface Name**).

10. Select **Block Unsolicited Incoming Packets** checkbox.

11. Select **Enable Connection Health Monitoring** checkbox (expands dialog).

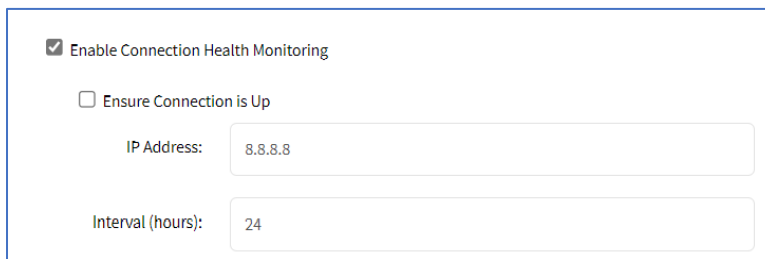

Enable Connection Health Monitoring  
 Ensure Connection is Up  
 IP Address:   
 Interval (hours):

Select **Ensure Connection is Up** checkbox.

Enter **IP Address**.

Enter **Interval (hours)**.

12. In *IPv4 Mode* menu, select one:

**No IPv4 Address** radio button.

**DHCP** radio button.

(optional) Enter **IPv4 DNS Server**.

Enter **IPv4 DNS Search** (defines a domain name for DNS lookups).

Enter **IPv4 Default Route Metric**.

Select **Ignore obtained IPv4 Default Gateway** checkbox.

Select **Ignore obtained DNS server** checkbox.

13. In *IPv6 Mode* menu:

**No IPv6 Address** radio button.

**Address Auto Configuration** radio button.

(optional) Enter **IPv6 DNS Server**.

Enter **IPv6 DNS Search** (defines a domain name for DNS lookups).

Enter **IPv6 Default Route Metric**.

Select **Ignore obtained IPv6 Default Gateway** checkbox.



Select **Ignore obtained DNS server** checkbox.

14. In *Mobile Broadband Connection* menu:

Enter **SIM-1 Phone Number**.

In *SIM-1 APN Configuration* menu, select one:

**Automatic** radio button.

**Manual** radio button (expands dialog)

Enter **SIM-1 User name** (user name to unlock the SIM).

Enter **SIM-1 Password**.

Enter **SIM-1 Access Point Name (APN)**.

Enter **SIM-1 Personal Identification Number (PIN)**.

Enter **SIM-1 MTU**. (bytes – can be set to ‘auto’ = 1500 bytes).

Select **Enable Data Usage Monitoring** checkbox (expands dialog):

Enter **SIM-1 Data Limit Value (GB)** (monthly data limit).

Enter **SIM-1 Data Warning (%)** (percentage that triggers an alarm).

Enter **SIM-1 Renew Day** (day to reset accumulated data).

Select **Enable IP Passthrough** checkbox (expands dialog)

On **Ethernet Connection** drop-down, select one (selection varies depending on device).

Enter **MAC Address** (if blank, the system uses DHCP to get the device).

Enter **Port Intercepts** (any ports that should NOT pass through the Nodegrid device).

Select **Enable Global Positioning System (GPS)** checkbox (displays menu).

Enter **Polling Time (min)**.

On **GPS Antenna** drop-down, select one (**Shared GPS/Rx diversity(aux) antenna**, **Dedicated Active GPS antenna**, **Dedicated Passive GPS antenna**)

(if applicable) Select **Enable Second SIM card** checkbox.

Repeat entries for SIM-2 settings. There is a setting **Active SIM card** that can designate SIM-2 as the primary SIM card.

15. Click **Save**.

## Add VLAN Interface

VLAN Interfaces allow the Nodegrid system to natively tag network traffic with a specific VLAN ID. For this, a VLAN Interface needs to be created. The VLAN interface will behave and allows the same settings as any other network interface on in Nodegrid solution. The new interface will be bound to a specific physical interface and the administrator as the ability to define the VLAN ID.

Ports can be assigned, as needed. By default, VLAN 1 and VLAN 2 exist. All ports belong to VLAN 1 except BACKPLANE1 and SFP1 (belongs to VLAN 2).

**WebUI Procedure**

1. Go to *Network :: Connections*.
2. Click **Add** (displays dialog).
3. Enter **Name**.
4. On **Type** drop-down, select **VLAN**.

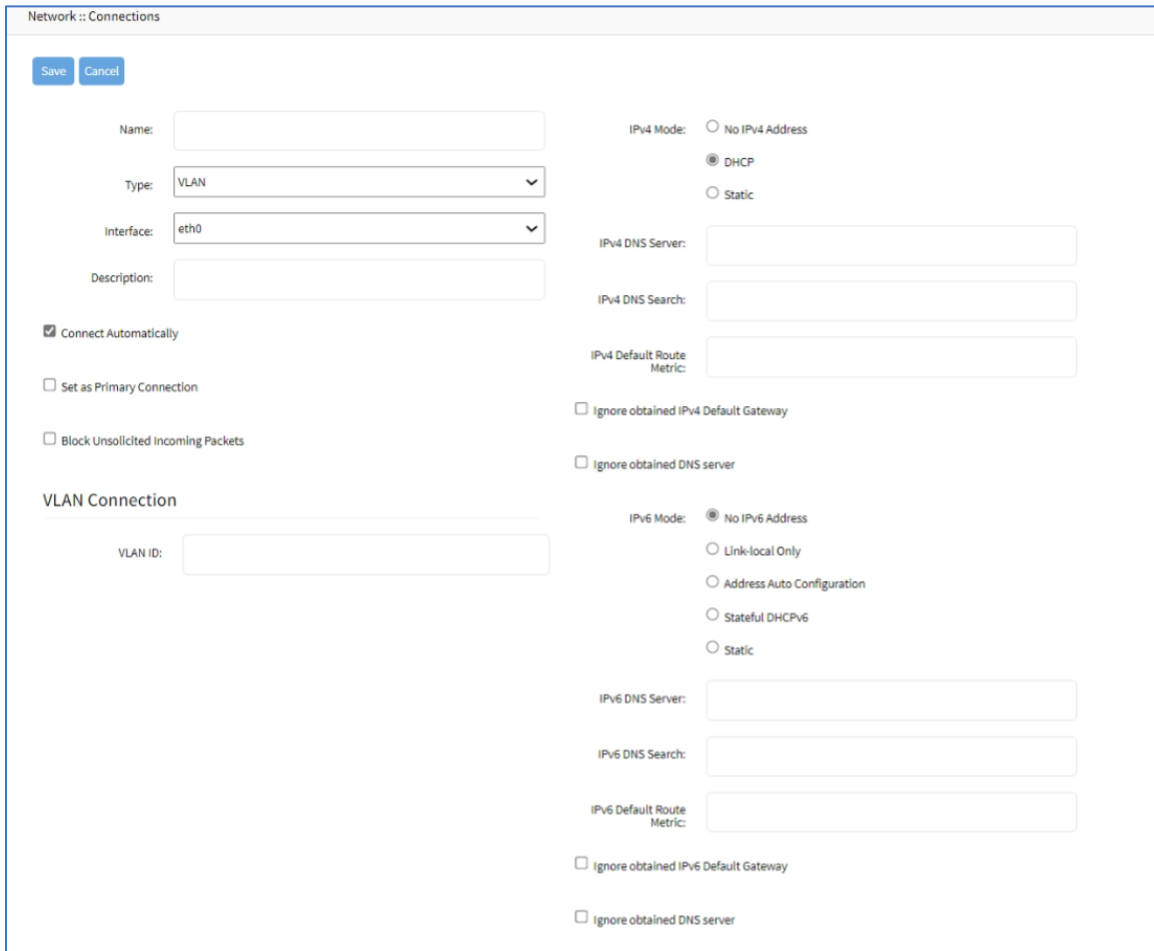

5. On **Interface** drop-down, select one.
6. Enter **Description**.
7. Select **Connect Automatically** checkbox (connection is automatically established at startup).
8. Select **Set as Primary Connection** (defines interface as the primary connection. Only one interface can be the primary.)
9. Select **Block Unsolicited Incoming Packets** checkbox.
10. In *VLAN Connection* menu, enter **VLAN ID**:

11. In *IPv4 Mode* menu, select one:

**No IPv4 Address** radio button.

**DHCP** radio button.

**Static** radio button (expands dialog):

Enter **IP Address**.

Enter **BitMask**.

(optional) Enter **Gateway IP**:

(optional) Enter **IPv4 DNS Server**.

Enter **IPv4 DNS Search** (defines a domain name for DNS lookups).

Enter **IPv4 Default Route Metric**.

Select **Ignore obtained IPv4 Default Gateway** checkbox.

Select **Ignore obtained DNS server** checkbox.

12. In *IPv6 Mode* menu:

**No IPv6 Address** radio button.

**Link local Only** radio button.

**Address Auto Configuration** radio button.

**Stateful DHCPv6** radio button.

**Static** radio button (if selected, displays menu):

Enter **IP Address**.

Enter **Prefix Length**.

(optional) Enter **Gateway IP**.

(optional) Enter **IPv6 DNS Server**.

Enter **IPv6 DNS Search** (defines a domain name for DNS lookups).

Enter **IPv6 Default Route Metric**.

Select **Ignore obtained IPv6 Default Gateway** checkbox.

Select **Ignore obtained DNS server** checkbox.

13. Click **Save**.

## Add WiFi Interface

The System support a Nodegrid device as a WiFi client or access point. A compatible WiFi module must be installed.

By default, a hotspot interface is defined which configures the device as an access point (if a WiFi module is present). To use the Nodegrid as an Access Point, update the values.

**WebUI Procedure**

1. Go to *Network :: Connections*.
2. Click **Add** (displays dialog).
3. Enter **Name**.
4. On **Type** drop-down, select **WiFi**.

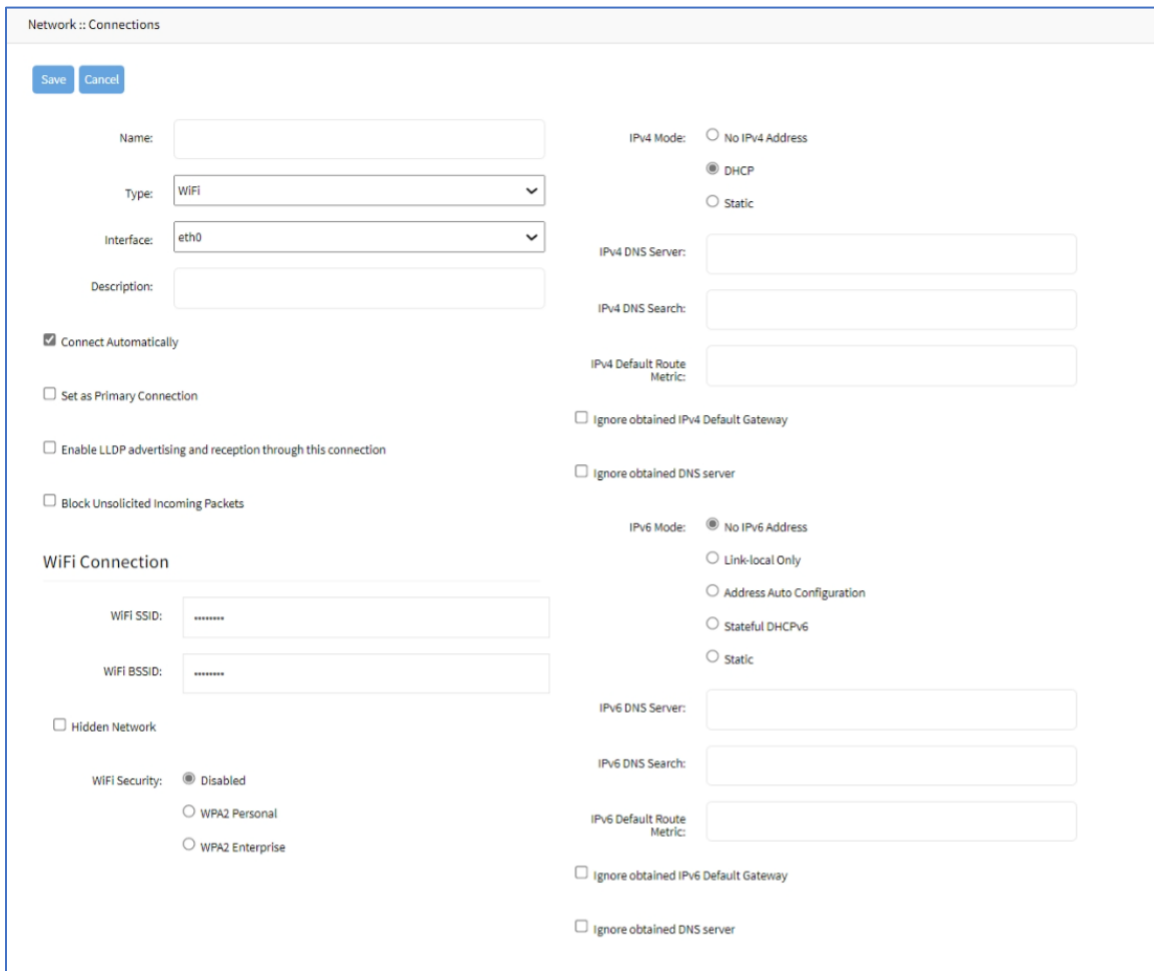

The screenshot shows the 'Network :: Connections' configuration dialog. It includes fields for Name, Type (set to WiFi), Interface (set to eth0), and Description. There are checkboxes for 'Connect Automatically', 'Set as Primary Connection', 'Enable LLDP advertising and reception through this connection', and 'Block Unsolicited Incoming Packets'. The 'WiFi Connection' section has fields for WiFi SSID and BSSID, a 'Hidden Network' checkbox, and 'WiFi Security' options (Disabled, WPA2 Personal, WPA2 Enterprise). The IPv4 and IPv6 sections have radio buttons for 'No IPv4/IPv6 Address', 'DHCP', 'Static', 'Link-local Only', 'Address Auto Configuration', and 'Stateful DHCPv6'. There are also input fields for DNS servers and default route metrics, and checkboxes to ignore obtained default gateways and DNS servers.

5. On **Interface** drop-down, select one.
6. Enter **Description**.
7. Select **Connect Automatically** checkbox (connection is automatically established at startup).
8. Select **Set as Primary Connection** (defines interface as the primary connection. Only one interface can be the primary.)
9. Select **Enable LLDP advertising and reception through this connection** checkbox.

Enable LLDP advertising and reception through this connection

Port ID:

Port Description:

On **Port ID** drop-down, select one (**Interface Name, Interface Index**).

On **Port Description** drop-down, select one (**Interface Description, Interface Name**).

10. Select **Block Unsolicited Incoming Packets** checkbox.

11. In *WiFi Connection* menu:

Enter **WiFi SSID**.

Enter **WiFi BSSID** (MAC address of the Access Point).

Select **Hidden Network** checkbox (if applicable).

In *WiFi Security* menu (select one):

**Disabled** radio button.

**WPA2 Personal** radio button (if selected, displays menu).

Enter **WPA shared key**.

**WPA2 Enterprise** radio button (if selected, displays menu):

Enter **Username**.

Enter **Password**.

On **Method** drop-down, select one.

On **Phase 2 Authentication** drop-down, select one.

Select **Validate server certificate** checkbox.

12. In *IPv4 Mode* menu, select one:

**No IPv4 Address** radio button.

**DHCP** radio button.

**Static** radio button (expands dialog):

Enter **IP Address**.

Enter **BitMask**.

(optional) Enter **Gateway IP**:

(optional) Enter **IPv4 DNS Server**.

Enter **IPv4 DNS Search** (defines a domain name for DNS lookups).

Enter **IPv4 Default Route Metric**.

Select **Ignore obtained IPv4 Default Gateway** checkbox.

Select **Ignore obtained DNS server** checkbox.

13. In *IPv6 Mode* menu:

**No IPv6 Address** radio button.

**Link local Only** radio button.

**Address Auto Configuration** radio button.

**Stateful DHCPv6** radio button.

**Static** radio button (expands dialog):

Enter **IP Address**.

Enter **Prefix Length**.

(optional) Enter **Gateway IP**.

(optional) Enter **IPv6 DNS Server**.

Enter **IPv6 DNS Search** (defines a domain name for DNS lookups).

Enter **IPv6 Default Route Metric**.

**Ignore obtained IPv6 Default Gateway** checkbox.

**Ignore obtained DNS server** checkbox.

14. Click **Save**.

## Add Bridge Interface

With Bridge interfaces, the System can create a virtual switch that crosses one or more interfaces. The switch is completely transparent to the network interfaces and does not require additional setup. The most common use for a bridge network is easy network access for any running NFV (outside as well as the Nodegrid System). Bridge network interfaces use the same network configuration options as all Ethernet interfaces.

### WebUI Procedure

1. Go to *Network :: Connections*.
2. Click **Add** (displays dialog).
3. Enter **Name**.
4. On **Type** drop-down, select **Bridge**.

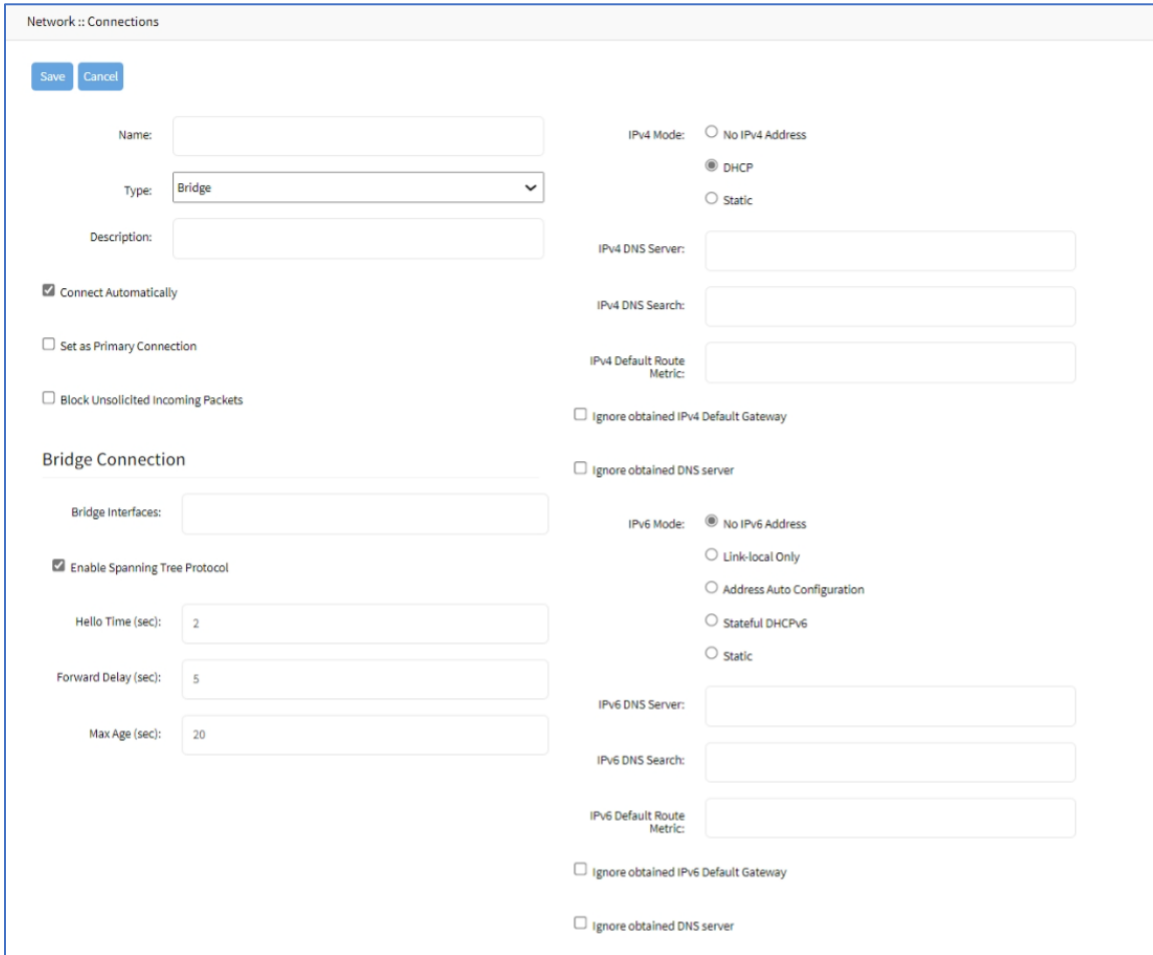

5. Enter **Description**.
6. Select **Connect Automatically** checkbox (connection is automatically established at startup).
7. Select **Set as Primary Connection** (defines interface as the primary connection. Only one interface can be the primary.)
8. Select **Block Unsolicited Incoming Packets** checkbox.
9. In *Bridge Connection* menu:
  - Enter **Bridge Interfaces** (comma-separated list of physical interfaces).
  - Select **Enable Spanning Tree Protocol** checkbox.
  - Enter **Hello Time (sec)** (number of seconds a HELLO packet is sent when Spanning Tree is enabled).
  - Enter **Forward Delay (sec)** (packet forward delay when Spanning Tree is enabled).
  - Enter **Max Age (sec)** (maximum age for packages when Spanning Tree is enabled).
10. In *IPv4 Mode* menu, select one:
  - No IPv4 Address** radio button.

**DHCP** radio button.

**Static** radio button (if selected, displays menu):

Enter **IP Address**.

Enter **BitMask**.

(optional) Enter **Gateway IP**:

(optional) Enter **IPv4 DNS Server**.

Enter **IPv4 DNS Search** (defines a domain name for DNS lookups).

Enter **IPv4 Default Route Metric**.

Select **Ignore obtained IPv4 Default Gateway** checkbox.

Select **Ignore obtained DNS server** checkbox

11. In *IPv6 Mode* menu:

**No IPv6 Address** radio button

**Link local Only** radio button

**Address Auto Configuration** radio button

**Stateful DHCPv6** radio button.

**Static** radio button (expands dialog):

Enter **IP Address**.

Enter **Prefix Length**.

(optional) Enter **Gateway IP**.

(optional) Enter **IPv6 DNS Server**.

Enter **IPv6 DNS Search** (defines a domain name for DNS lookups).

Enter **IPv6 Default Route Metric**.

Select **Ignore obtained IPv6 Default Gateway** checkbox.

Select **Ignore obtained DNS server** checkbox.

12. Click **Save**.

## Add Analog Modem Interface

With the analog modem interface, administrators can configure an existing analog modem and required PPP connection details. A supported analog modem must be connected to the Nodegrid System.

### WebUI Procedure

1. Go to *Network :: Connections*.
2. Click **Add** (displays dialog).
3. Enter **Name**.



- On **Type** drop-down, select **Analog MODEM**.

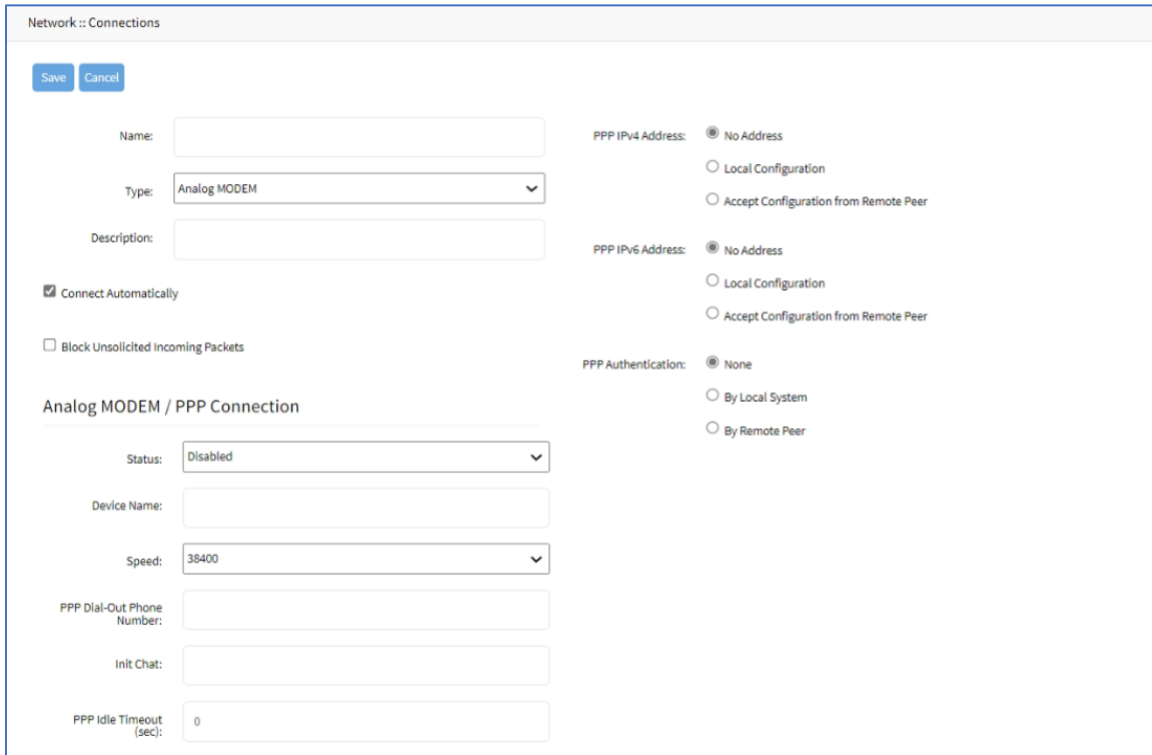

- Enter **Description**.
- Select **Connect Automatically** checkbox (connection is automatically established at startup).
- Select **Block Unsolicited Incoming Packets** checkbox.
- In *Analog MODEM / PPP Connection* menu:

On **Status** drop-down, select one (**Enabled, Disabled**).

Enter **Device Name**.

On **Speed** drop-down, select one (**9600, 19200, 38400, 57600, 115200**).

Enter **PPP Dial-Out Phone Number**.

Enter **Init Chat** (a specific AT init string, if required).

Enter **PPP Idle Timeout (sec)** (connection idle timeout after which the connection is automatically disconnected. 0 sec = connection is not automatically disconnected.)

- In *PPP IPv4 Address* menu (select one):

**No Address** radio button.

**Local Configuration** radio button (displays):

Enter **Local Address**.

Enter **Remote Address**.

**Accept Configuration from Remote Peer** radio button

10. In *PPP IPv6 Address* menu (select one):

**No Address** radio button.

**Local Configuration** radio button (expands dialog)

Enter **Local Address (LL)**.

Enter **Remote Address (LL)**.

**Accept Configuration from Remote Peer** radio button.

11. In *PPP Authentication* menu:

**None** radio button.

By **Local System** radio button (displays menu):

On **Authentication Protocol** drop-down, select one (**PAP, CHAP, EAP**).

By **Remote Peer** radio button (displays menu):

Enter **Remote Username**.

Enter **Remote Passphrase**.

12. Click **Save**.

## Add PPPoE Interface

### *WebUI Procedure*

1. Go to *Network :: Connections*.
2. Click **Add** (displays dialog).
3. Enter **Name**.
4. On **Type** drop-down, select **PPPoE**.

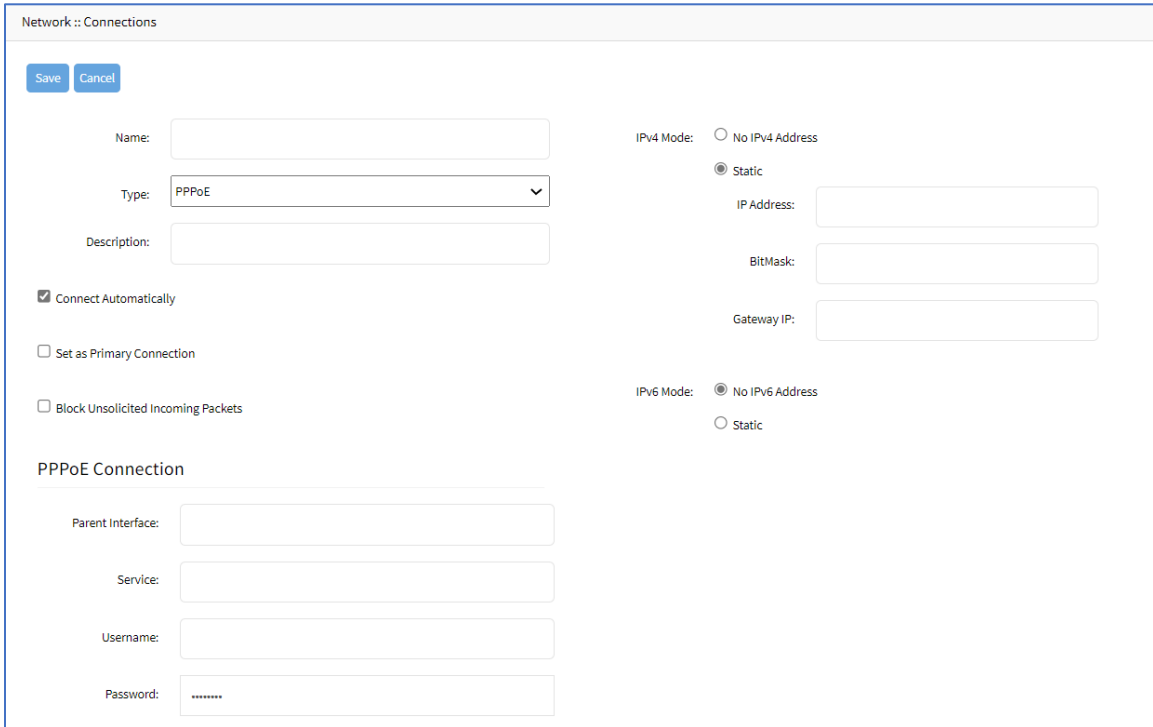

5. Enter **Description**.
6. Select **Connect Automatically** checkbox (connection is automatically established at startup).
7. Select **Set as Primary Connection** (defines interface as the primary connection. Only one interface can be the primary.)
8. Select **Block Unsolicited Incoming Packets** checkbox.
9. In *PPPoE Connection* menu:
  - Enter **Parent Interface** (default: blank).
 

If entered, specifies the parent interface name on which this PPPoE connection should be created. If blank, connection is activated on the ethernet interface. (default: blank)
  - Enter **Service** (default: blank).
 

If specified, PPPoE only initiates sessions with access concentrators that provide the specified service. For most providers, leave blank. Required only if there are multiple access concentrators or a required specific service.

Access concentrators grants access to multiple users with needing a dedicated connection for each user.
  - Enter **Username**.
  - Enter **Password**.
10. In *IPv4 Mode* menu, select one:
  - No IPv4 Address** radio button.
  - Static** radio button (if selected, displays menu):

Enter **IP Address**.

Enter **BitMask**.

(optional) Enter **Gateway IP**:

11. In *IPv6 Mode* menu:

**No IPv6 Address** radio button.

**Static** radio button (expands dialog):

Enter **IP Address**.

Enter **Prefix Length**.

(optional) Enter **Gateway IP**.

12. Click **Save**.

## Add Loopback Interface

### WebUI Procedure

1. Go to *Network :: Connections*.
2. Click **Add** (displays dialog).
3. Enter **Name**.
4. On **Type** drop-down, select **Loopback**.

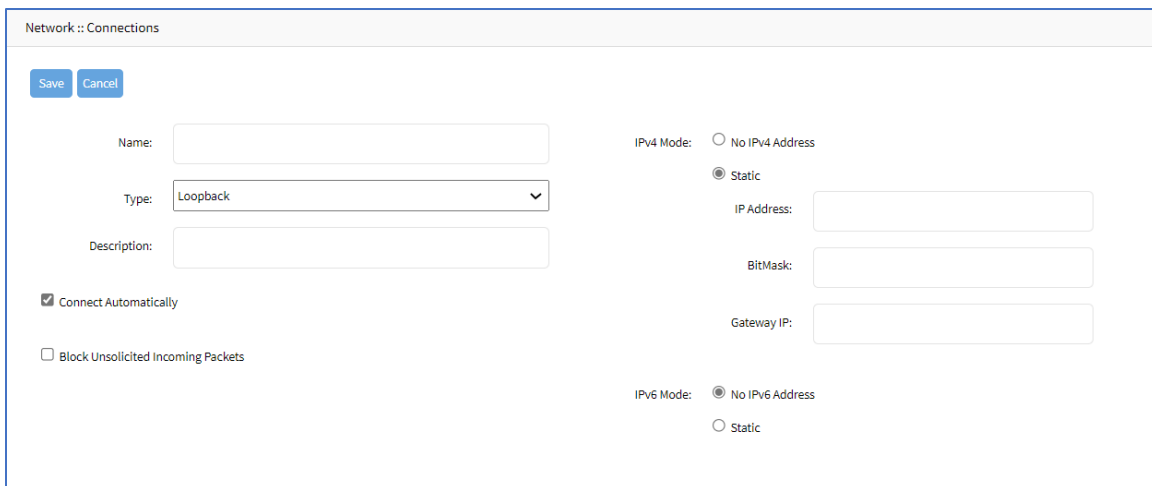

5. Enter **Description**.

6. Select **Connect Automatically** checkbox (connection is automatically established at startup).

7. Select **Block Unsolicited Incoming Packets** checkbox.

8. In *IPv4 Mode* menu, select one:

**No IPv4 Address** radio button.

**Static** radio button (expands dialog):

Enter **IP Address**.

Enter **BitMask**.

(optional) Enter **Gateway IP**:

9. In *IPv6 Mode* menu:

**No IPv6 Address** radio button

**Static** radio button (expands dialog):

Enter **IP Address**.

Enter **Prefix Length**.

(optional) Enter **Gateway IP**.

10. Click **Save**.

## Switch tab (NSR, GSR, BSR)

These functions are only available on Nodegrid NSR, GSR, BSR devices.

Users can configure the built-in network switch. Supported functions include enable/disable individual ports, as well as creation of tagged (trunk) and untagged (access) ports.

Each card that provides network connectivity (Backplane 0/1 and SFP0/1) are directly connected to the switch. By default, the interfaces Backplane0/1 and SFP0/1 are active. By default, these can provide or consume ZTP, PXE and DHCP requests. By default, all other network interfaces are disabled.

All ports belong to VLAN1 and provide direct communication between enabled interfaces, except Backplane1 and SFP1 (which belong to VLAN2).

### Physical Interfaces

Connection	Model	Physical interface
ETH0	all	eth0
ETH1	Nodegrid NSC, NSR	eth1
BACKPLANE0	Nodegrid NSR, BSR, GSR	NSR: backplane0 is in the same VLAN as SFP0 and switch ports by default GSR, BSR: backplane0 is in the same VLAN as SFP0 and switch ports by default
BACKPLANE1	Nodegrid NSR, GSR	NSR: backplane1 is in the same VLAN as SFP1 by default GSR: backplane1 is not in any VLAN by default
SFP0	Nodegrid GSR, NSR	GSR: sfp0 NSR: SFP0 is in the same VLAN as backplane0 and switch ports by default
SFP1	Nodegrid GSR, NSR	GSR: sfp1 NSR: SFP1 is connected to backplane1 by default

Connection	Model	Physical interface
hotspot	all	Interface is bound to wireless adapter (if available).

### Switch Interfaces sub-tab

These provide an overview of all switch ports, current status, and allow enable/disable. Current VLAN associates (tagged and untagged) are shown and Port VLAN IDs can be configured.

#### NSR

Interface	Status	Speed	Port VLAN ID	Jumbo Frame	ACL Ingress	ACL Egress	MSTP Status	802.1x Status	Description
<input checked="" type="checkbox"/> sfp0	Enabled	Auto	1	Disabled	None	None	Disabled	Disabled	
<input type="checkbox"/> sfp1	Enabled	Auto	2	Disabled	None	None	Disabled	Disabled	

#### GSR

Interface	Status	Speed	Port VLAN ID	Jumbo Frame	Description
<input type="checkbox"/> netS1	Enabled	Auto	1	Enabled	
<input type="checkbox"/> netS2	Enabled	Auto	1	Enabled	
<input type="checkbox"/> netS3	Enabled	Auto	1	Enabled	
<input type="checkbox"/> netS4	Enabled	Auto	1	Enabled	

## BSR

Interface	Status	Speed	Port VLAN ID	Jumbo Frame	Description
<input type="checkbox"/> netS1	Enabled	Auto	1	Enabled	
<input type="checkbox"/> netS2	Enabled	Auto	1	Enabled	
<input type="checkbox"/> netS3	Enabled	Auto	1	Enabled	
<input type="checkbox"/> netS4	Enabled	Auto	1	Enabled	

### Edit Switch Port Interface (BSR, GSR)

#### WebUI Procedure

1. Go to *Network :: Switch :: Switch Interfaces*.
2. In the table, select checkbox.
3. Click **Edit** (displays dialog).

4. As needed, make changes:
  - Status** drop-down (**enabled, disabled**).
  - Description**.
  - Speed** drop-down (**Auto, 10M, 100M, 1G**).

**Port VLAN ID.**

5. Click **Save**.

## Edit Switch Port Interface (NSR)

### WebUI Procedure

1. Go to *Network :: Switch :: Switch Interfaces*.
2. In the table, select checkbox.
3. Click **Edit** (displays dialog).

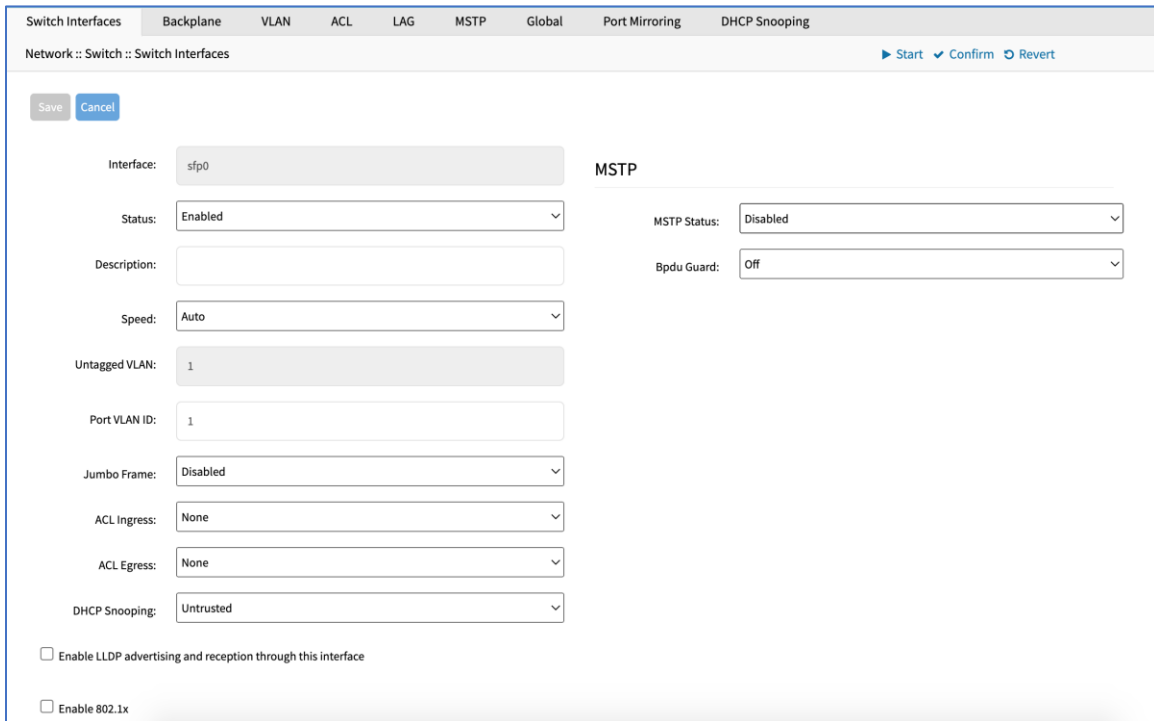

4. As needed, make changes:

**Status** drop-down (**enabled, disabled**).

**Description**.

**Speed** drop-down (**Auto, 10M, 100M, 1G, 10G**).

**Port VLAN ID**.

**Jumbo Frame** drop-down (**enabled, disabled**).

(if available) **ACL Ingress** drop-down (select one).

(if available) **ACL Egress** drop-down (select one).

**DHCP Snooping** drop-down (**Trusted, Untrusted**) (must be enabled on *Network :: Switch :: Global :: DHCP Snooping*).

**Enable LLDP advertising and reception through this interface** checkbox.



Enable **802.1x** checkbox.

5. In *MSTP* menu, select:

**MSTP Status** drop-down (**enabled, disabled**)

(To be active, *Network :: Switch :: Global :: Spanning Tree* status must be enabled).

**BPDU Guard** drop-down (selection varies). Protects Layer 2 Spanning Tree Protocol (STP) Topology from BPDU related attacks.

(To be active, *Network :: Switch :: Global :: Spanning Tree* status must be enabled).

6. Click **Save**.

## **Backplane sub-tab**

Backplane settings control the switch interfaces directly exposed to the Nodegrid Platform. For the Nodegrid to communicate with any existing switch ports or VLANs, at least one of the backplane interfaces must be part of the specific VLAN. The backplane settings display the current VLAN associations. The Port VLAN IDs can be set for the backplane interfaces.

**NOTE:** Display varies depending on device – GSR, BSR, or NSR).

## **Edit Backplane Settings**

### *WebUI Procedure*

1. Go to *Network :: Switch :: Backplane*.

2. In *backplane0*, make changes, as needed:

Enter **Port VLAN ID**.

(if active) On **Jumbo Frame** drop-down, select one (**Enabled, Disabled**).

3. In *backplane1*, make changes, as needed:

Enter **Port VLAN ID**.

(if active) On **Jumbo Frame** drop-down, select one (**Enabled, Disabled**).

4. (if shown) In *Slot1-0*, make changes, as needed (displays if a compute card is present in slot 1):

Enter **Port VLAN ID**.

(if active) On **Jumbo Frame** drop-down, select one (**Enabled, Disabled**).

5. (if shown) In *Slot1-1*, make changes, as needed (displays if a compute card is present in slot 1):

Enter **Port VLAN ID**.

(if active) On **Jumbo Frame** drop-down, select one (**Enabled, Disabled**).

6. Click **Save**.

## **VLAN sub-tab**

The Port VLAN ID is assigned to all incoming untagged packets. Port VLAN ID is used to forward packets to other ports which match this VLAN ID.

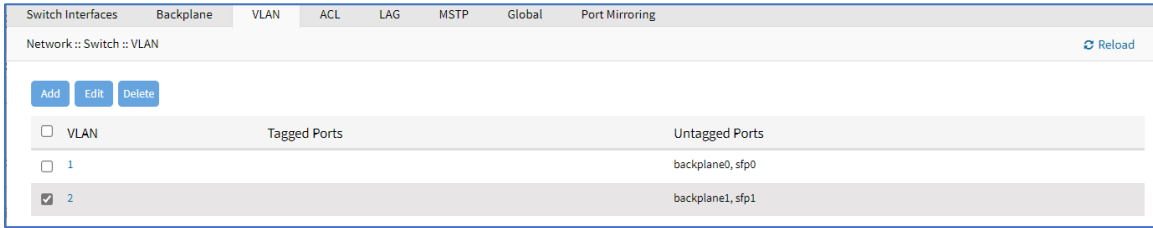

### Untagged/Access Ports

To assign a port to a specific VLAN as an untagged or access port, enable the port and change the PORT VLAN ID to the desired VLAN.

### Tagged/Trunk Ports

Tagged ports accepts any packet that belongs to an assigned VLAN. The VLAN must exist before the port can be assigned. The Egress packet includes the VLAN tag.

## Add VLAN

### WebUI Procedure

1. Go to *Network :: Switch :: VLAN*.
2. Click **Add** (displays dialog).

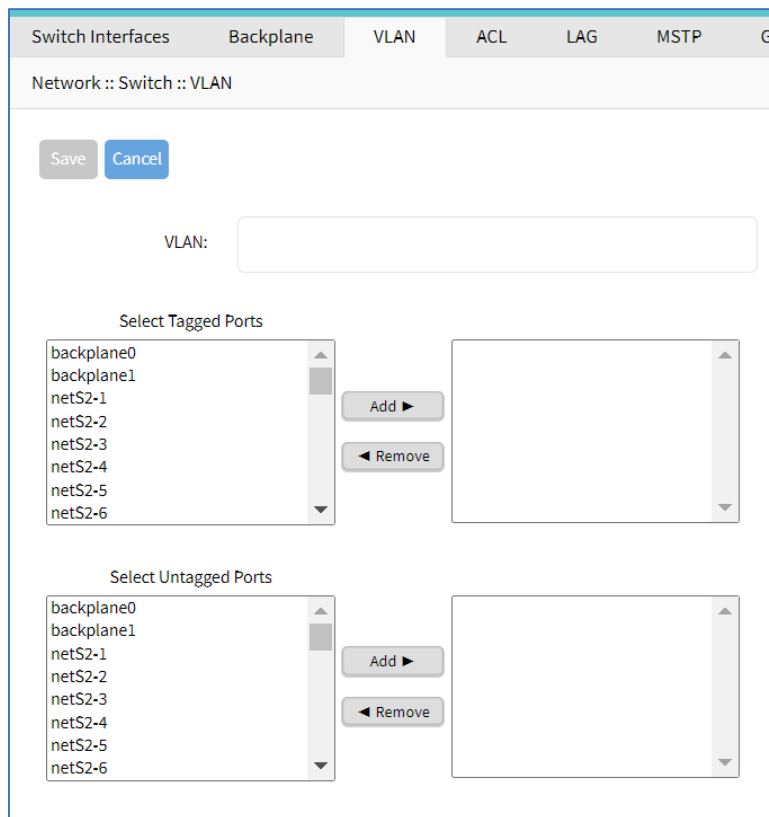

3. Enter **VLAN**.
4. In *Select Tagged Ports*, select from left-side panel, click **Add▶** to move to right-side panel.

To remove from right-side panel, select and click **Remove**.

5. In *Select Untagged Ports*, select from left-side panel, click **Add** to move to right-side panel.

To remove from right-side panel, select and click **Remove**.

6. Click **Save**.

## Edit VLAN

### WebUI Procedure

1. Go to *Network :: Switch :: VLAN*.
2. Select checkbox next to item to edit.
3. Click **Edit** (displays dialog).
4. Make changes, as needed.
5. Click **Save**.

## Delete VLAN

### WebUI Procedure

1. Go to *Network :: Switch :: VLAN*.
2. Select checkbox next to item to delete.
3. Click **Delete**.
4. On the confirmation pop-up dialog, click **OK**.

## PoE sub-tab (NSR with PoE card, GSR)

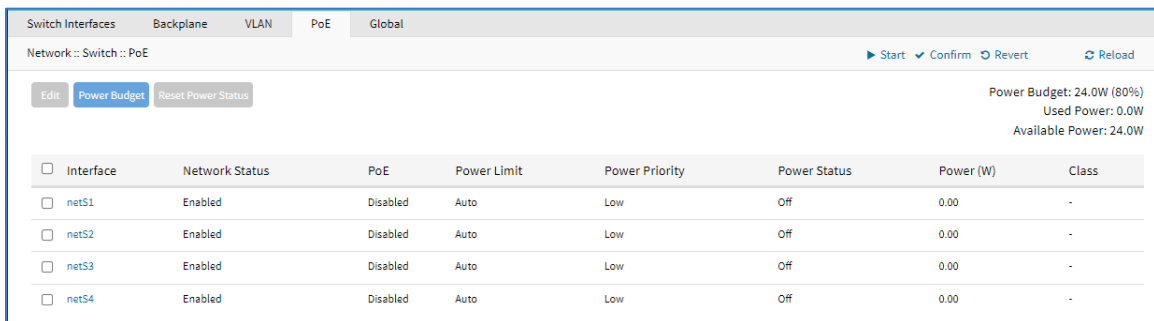

Interface	Network Status	PoE	Power Limit	Power Priority	Power Status	Power (W)	Class
<input type="checkbox"/> netS1	Enabled	Disabled	Auto	Low	Off	0.00	-
<input type="checkbox"/> netS2	Enabled	Disabled	Auto	Low	Off	0.00	-
<input type="checkbox"/> netS3	Enabled	Disabled	Auto	Low	Off	0.00	-
<input type="checkbox"/> netS4	Enabled	Disabled	Auto	Low	Off	0.00	-

## Edit PoE Configuration

1. Go to *Network :: Switch :: PoE*.
2. Select checkbox of interface to edit.
3. Click **Edit** (displays dialog).

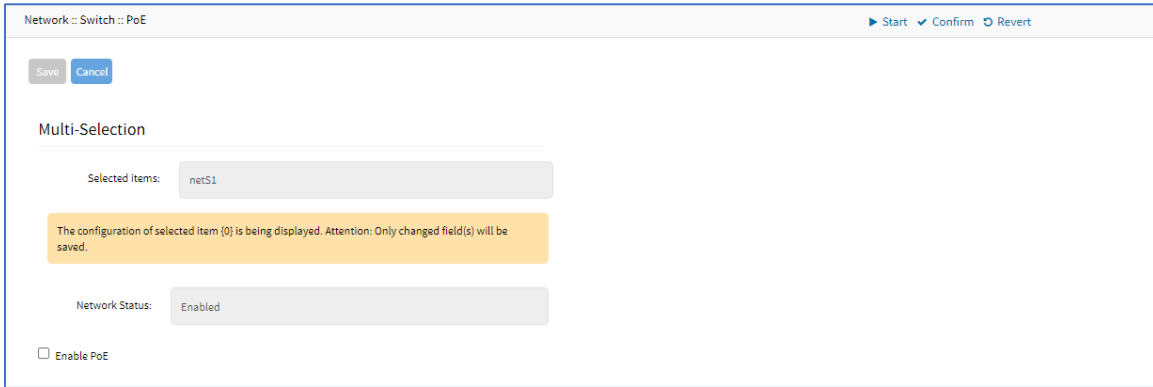

Network :: Switch :: PoE

Start Confirm Revert

Save Cancel

Multi-Selection

Selected Items: netS1

The configuration of selected item (0) is being displayed. Attention: Only changed field(s) will be saved.

Network Status: Enabled

Enable PoE

4. Select **Enable PoE** checkbox (expands dialog).

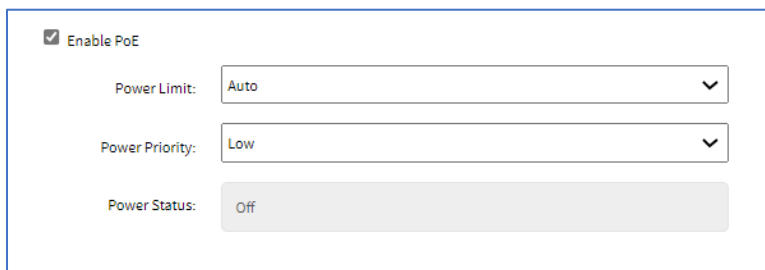

Enable PoE

Power Limit: Auto

Power Priority: Low

Power Status: Off

On **Power Limit** drop-down, select one (**Auto, 6W, 12W, 18W, 24W, 30W**).

On **Power Priority** drop-down, select one (**Low, High, Critical**).

5. Click **Save**.

### Configure Power Budget

1. Go to *Network :: Switch :: PoE*.
2. Select checkbox of interface.
3. Click **Power Budget** (displays dialog).

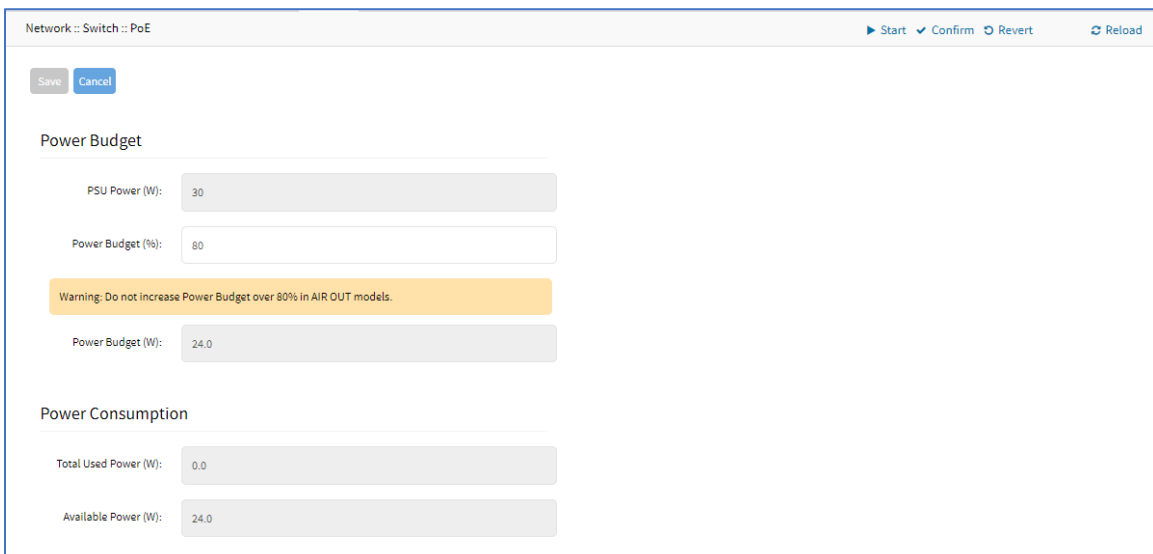

Network :: Switch :: PoE

Start Confirm Revert Reload

Save Cancel

Power Budget

PSU Power (W): 30

Power Budget (%): 80

Warning: Do not increase Power Budget over 80% in AIR OUT models.

Power Budget (W): 24.0

Power Consumption

Total Used Power (W): 0.0

Available Power (W): 24.0

4. In *Power Budget* menu:  
Enter **Power Budget (%)**.
5. In *Power Consumption* menu, review values.
6. Click **Save**.

### Reset Power Status

1. Go to *Network :: Switch :: PoE*.
2. Select checkbox of interface.
3. Click **Reset Power Status**.

The power error/alarm status of the selected interface is reset.

### ACL sub-tab (NSR only)

With the ACL (access control list) option, custom ACL rules can be managed (add, delete, edit) for each interface.

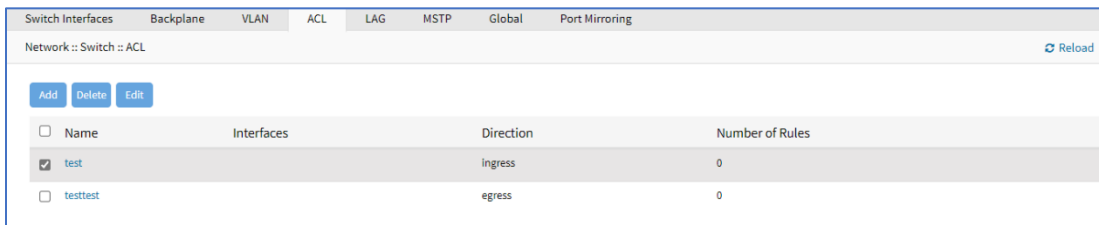

<input type="checkbox"/>	Name	Interfaces	Direction	Number of Rules
<input checked="" type="checkbox"/>	test		Ingress	0
<input type="checkbox"/>	testtest		egress	0

### Add ACL

#### WebUI Procedure

1. Go to *Network :: Switch :: ACL*.
2. Click **Add** (displays dialog).

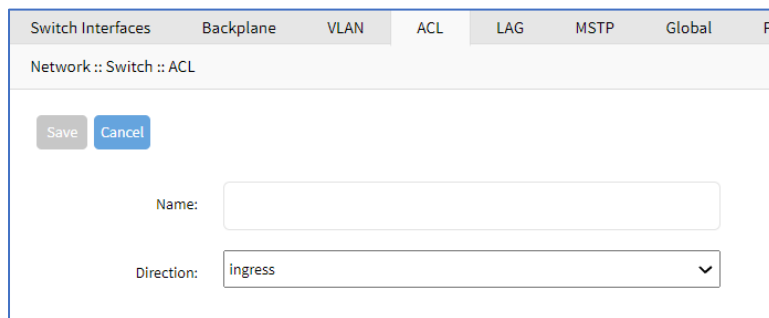

Network :: Switch :: ACL

Save Cancel

Name:

Direction:

3. Enter **Name**.
4. On **Direction** drop-down, select one (**ingress, egress**).
5. Click **Save**.

## Edit ACL

### WebUI Procedure

1. Go to *Network :: Switch :: ACL*.
2. Select checkbox next to item to edit.
3. Click **Edit** (displays dialog).
4. Make changes, as needed.
5. Click **Save**.

## Delete ACL

### WebUI Procedure

1. Go to *Network :: Switch :: ACL*.
2. Select checkbox next to item to delete.
3. Click **Delete**.
4. On the confirmation pop-up dialog, click **OK**.

## LAG sub-tab (NSR only)

Link aggregation allows combination of multiple network connections in parallel. This increases throughput beyond what a single connection sustains. Redundancy occurs in the event one of the links fails.

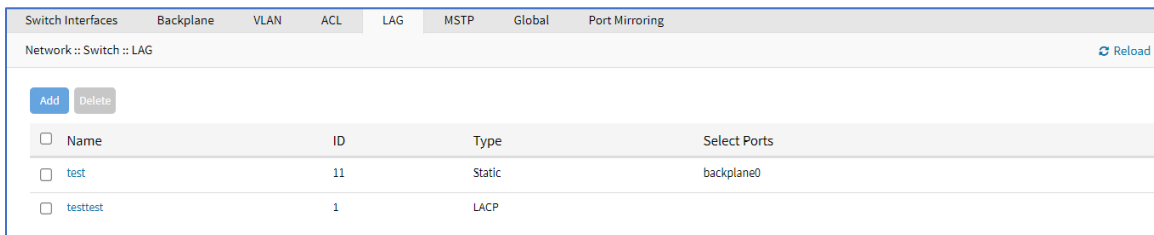

<input type="checkbox"/>	Name	ID	Type	Select Ports
<input type="checkbox"/>	test	11	Static	backplane0
<input type="checkbox"/>	testtest	1	LACP	

## Add LAG

### WebUI Procedure

1. Go to *Network :: Switch :: LAG*.
2. Click **Add** (displays dialog).

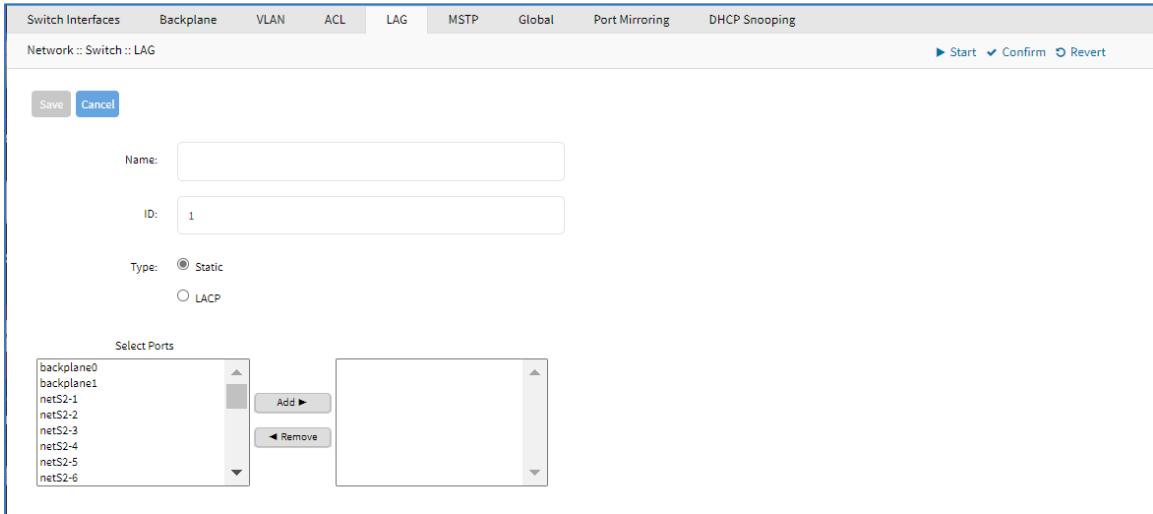

3. Enter **Name**.
4. Enter **ID**.
5. On *Type* menu, select one:
  - Static** radio button.
  - LACP** radio button (expands dialog).

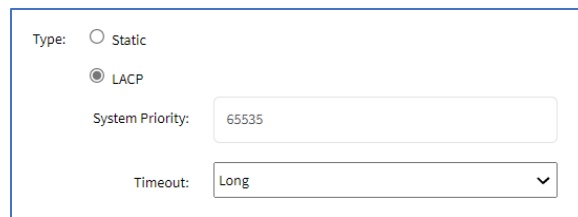

Enter **System Priority**.

On **Timeout** drop-down, select one (**Long**, **Short**).

6. In *Select Ports*, select from left-side panel, click **Add** to move to right-side panel.  
To remove from right-side panel, select and click **Remove**.
7. Click **Save**.

## Edit LAG

### WebUI Procedure

1. Go to *Network :: Switch :: LAG*.
2. In the *Name* column, click on a name (displays dialog).
3. Make changes, as needed.
4. Click **Save**.

## Delete LAG

### WebUI Procedure

1. Go to *Network :: Switch :: LAG*.
2. Select checkbox next to item to delete.
3. Click **Delete**.
4. On the confirmation pop-up dialog, click **OK**.

## MSTP sub-tab (NSR only)

MSTP (Multiple Spanning Tree Protocol) exchanges BPDUs (Bridge Protocol Data Units) to prevent loops in MSTI (Multiple Spanning Tree Instances) and DIST (Common and Internal Spanning Tree).

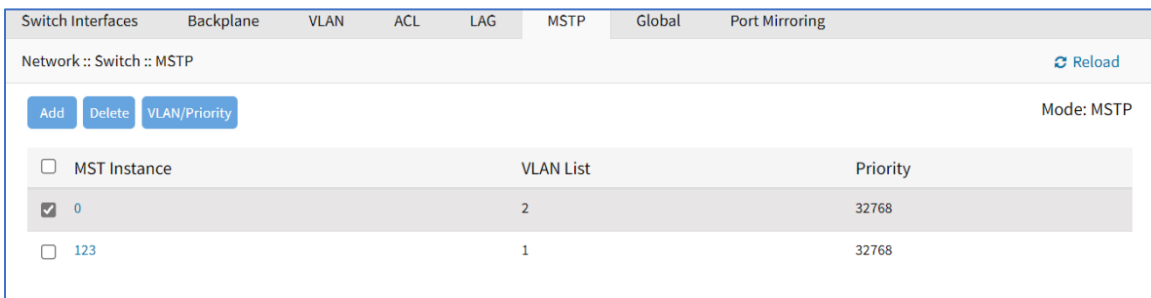

MST Instance	VLAN List	Priority
<input checked="" type="checkbox"/> 0	2	32768
<input type="checkbox"/> 123	1	32768

## Add MSTP

### WebUI Procedure

1. Go to *Network :: Switch :: MSTP*.
2. Click **Add** (displays dialog).

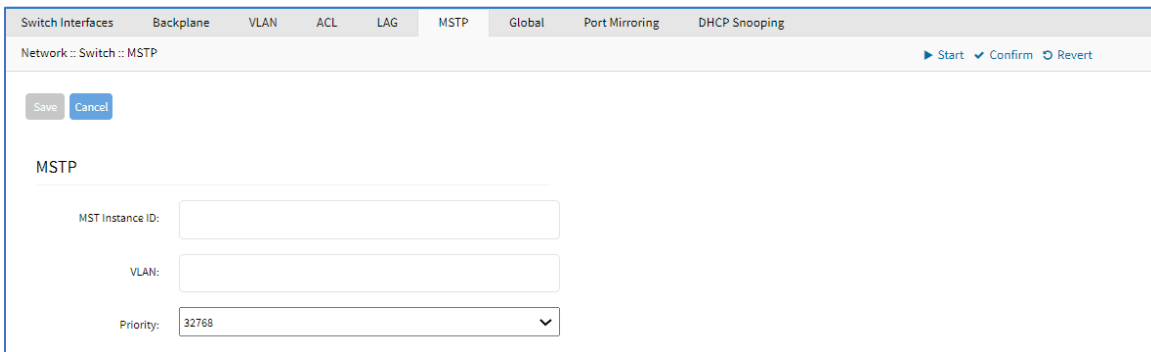

MSTP

MST Instance ID:

VLAN:

Priority:

3. Enter **MST Instance ID**.
4. Enter **VLAN**.
5. On **Priority** drop-down, select one (**0, 4096, 8192, 12288, 16384, 20480, 24594, 28672, 32768, 40960, 45056, 49152, 53248, 57344, 61440**).
6. Click **Save**.



## Edit MSTP

### WebUI Procedure

1. Go to *Network :: Switch :: MSTP*.
2. In *Interface* column, click a name (displays dialog).

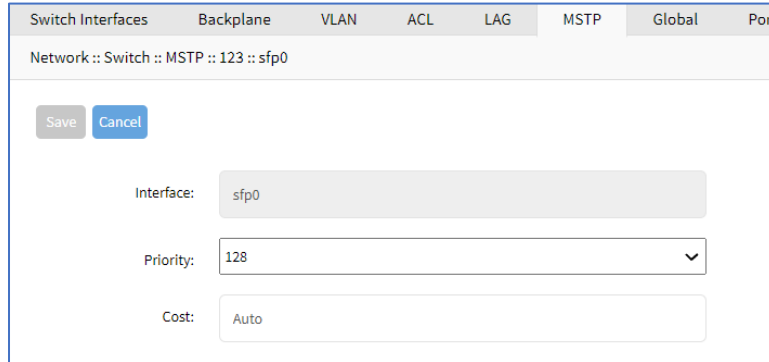

3. As needed, make changes:

On **Priority** drop-down, select one (**0, 16, 32, 48, 64, 80, 96, 112, 128, 144, 160, 176, 192, 208, 224, 240**).

Enter **Cost** (default: Auto).

4. Click **Save**.

## Delete MSTP

### WebUI Procedure

1. Go to *Network :: Switch :: MSTP*.
2. In the *MST Interface* column, select checkbox.
3. Click **Delete**.
4. On confirmation pop-up dialog, click **OK**.

## Set VLAN/Priority

### WebUI Procedure

1. Go to *Network :: Switch :: MSTP*.
2. In the *MST Interface* column, select checkbox.
3. Click **VLAN/Priority** (displays dialog).

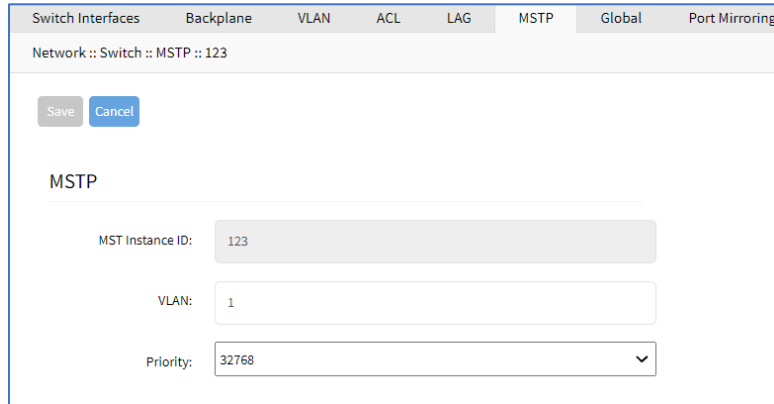

4. Make changes, as needed.
5. Click **Save**.

### Global sub-tab (BSR, GSR)

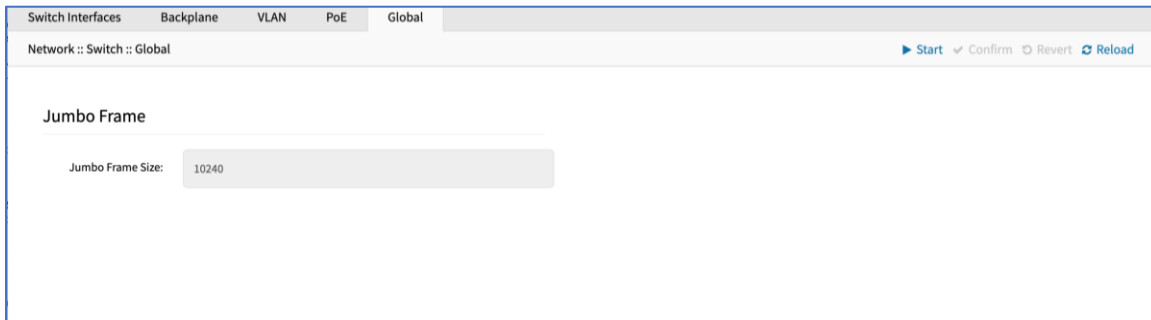

### Edit Global Settings

Details cannot be edited.

## Global sub-tab (NSR only)

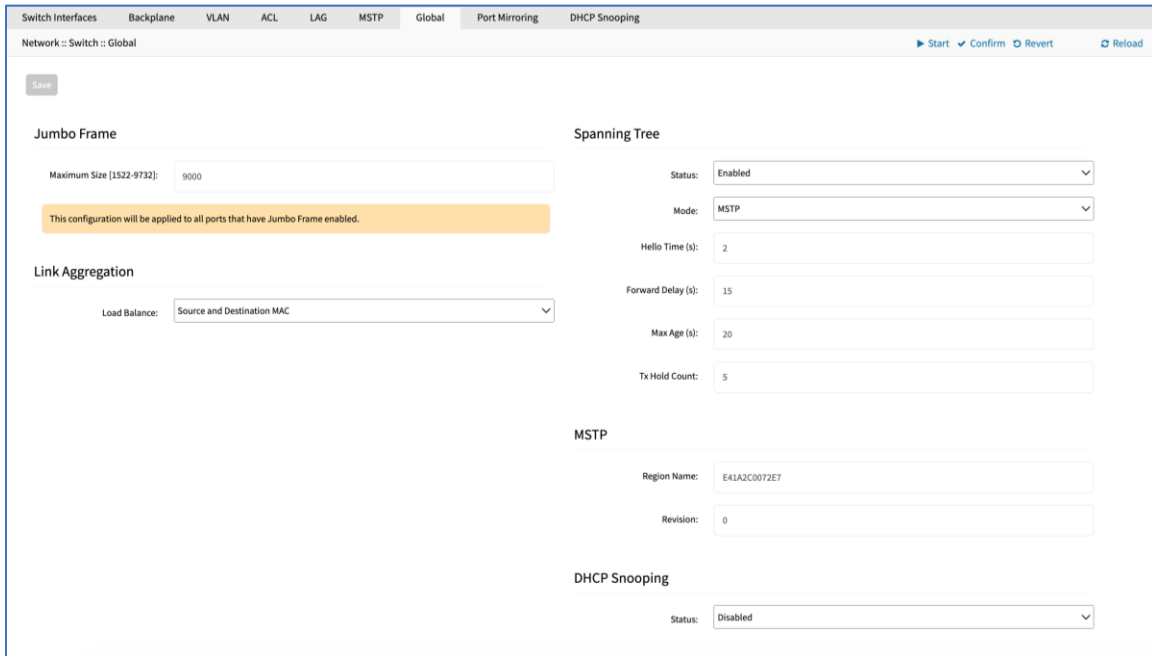

The screenshot displays the 'Global' configuration page for a switch. The navigation tabs at the top include: Switch Interfaces, Backplane, VLAN, ACL, LAG, MSTP, Global (selected), Port Mirroring, and DHCP Snooping. The page title is 'Network :: Switch :: Global'. A 'Save' button is located at the top left. The configuration is divided into several sections:

- Jumbo Frame:** Maximum Size (1522-9732) is set to 9000. A note states: 'This configuration will be applied to all ports that have Jumbo Frame enabled.'
- Link Aggregation:** Load Balance is set to 'Source and Destination MAC'.
- Spanning Tree:** Status is 'Enabled', Mode is 'MSTP', Hello Time (s) is 2, Forward Delay (s) is 15, Max Age (s) is 20, and Tx Hold Count is 5.
- MSTP:** Region Name is 'E41A2C0072E7' and Revision is 0.
- DHCP Snooping:** Status is 'Disabled'.

## Edit Global Settings

### WebUI Procedure

1. Go to *Network :: Switch :: Global*.
1. In *Jumbo Frame* menu:
  - Enter **Maximum Size (1522 to 9732)**.
2. In *Link Aggregation* menu:
  - In **Load Balance** drop-down, select one (**Source and Destination IP, Source and Destination MAC, Source and Destination MAC and IP, Source and Destination MAC and IP and TCP/UDP Ports**).
3. In *Spanning Tree* menu:
  - In **Status** drop-down, select one (**Enabled, Disabled**).
  - In **Mode** drop-down, select one (**MSTP**).
  - Enter **Hello Time (sec)**.
  - Enter **Forward Delay (sec)**.
  - Enter **Max Age (sec)**.
  - Enter **Tx Hold Count**.
4. In *MSTP* menu:
  - Enter **Region Name**.

Enter **Revision**.

5. In *DHCP Snooping* menu:

On **Status** drop-down, select one (**Enabled, Disabled**)

**NOTE:** DHCP Snooping must be enabled here to be activated on this device.

6. Click **Save**.

### Port Mirroring sub-tab (NSR only)

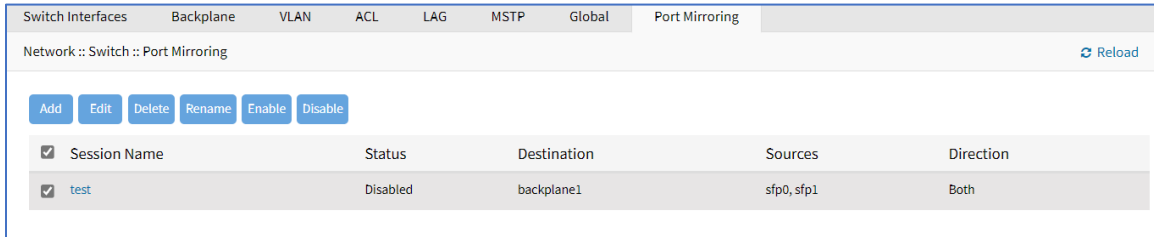

Session Name	Status	Destination	Sources	Direction
test	Disabled	backplane1	sfp0, sfp1	Both

## Add Port Mirroring

### WebUI Procedure

1. Go to *Network :: Switch :: Port Mirroring*.
2. Click **Add** (displays dialog).

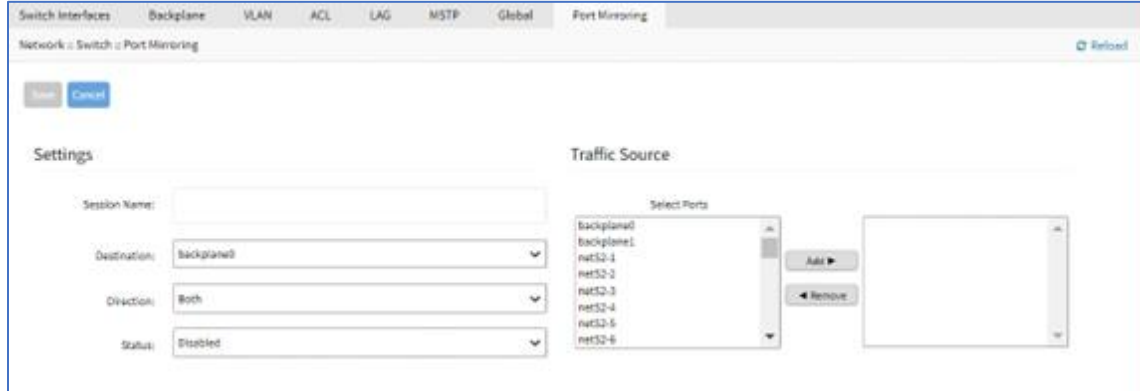

The dialog box is titled 'Add Port Mirroring' and contains two main sections: 'Settings' and 'Traffic Source'.

**Settings:**

- Session Name:
- Destination:
- Direction:
- Status:

**Traffic Source:**

Select Ports:

Buttons: Add, Remove

3. In *Settings* menu:

Enter **Session Name**.

On **Destination** drop-down, select one (**backplane0, backplane1, netS2-(1-16), netS3-(1-8), netS4-(1-16), sfp0, sfp1, slot1-0, slot1-1**).

On **Direction** drop-down, select one (**Both, Egress, Ingress**).

On **Status** drop-down, select one (**Enabled, Disabled**).

4. In *Traffic Source* menu:

On *Traffic Source*, select from left-side panel, click **Add** to move to right-side panel.

To remove from right-side panel, select, and click **Remove**.

5. Click **Save**.

## Edit Port Mirroring

### WebUI Procedure

1. Go to *Network :: Switch :: Port Mirroring*.
2. In *Session Name* column, select checkbox.
3. Click **Edit**.
4. Make changes, as needed.
5. Click **Save**.

## Delete Port Mirroring

### WebUI Procedure

1. Go to *Network :: Switch :: Port Mirroring*.
2. In *Session Name* column, select checkbox.
3. Click **Delete**.
4. On confirmation pop-up dialog, click **OK**.

## Rename Port Mirroring

### WebUI Procedure

1. Go to *Network :: Switch :: Port Mirroring*.
2. In *Session Name* column, select checkbox.
3. Click **Rename**.
4. On the dialog, enter **New Name**.
5. Click **Save**.

## Enable/Disable Port Mirroring

### WebUI Procedure

1. Go to *Network :: Switch :: Port Mirroring*.
2. In *Session Name* column, select checkbox.
3. Click **Enable** (enables port mirroring).
4. Click **Disable** (disables port mirroring).

## DHCP Snooping sub-tab (NSR only)

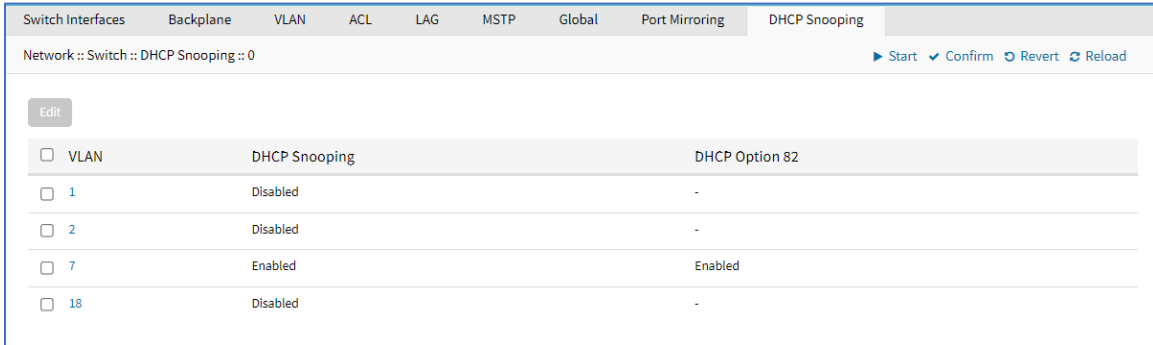

### Enable DHCP Snooping

1. Go to *Network :: Switch :: DHCP Snooping*.
2. Select a checkbox with a disabled VLAN.
3. Click **Edit** (displays dialog).

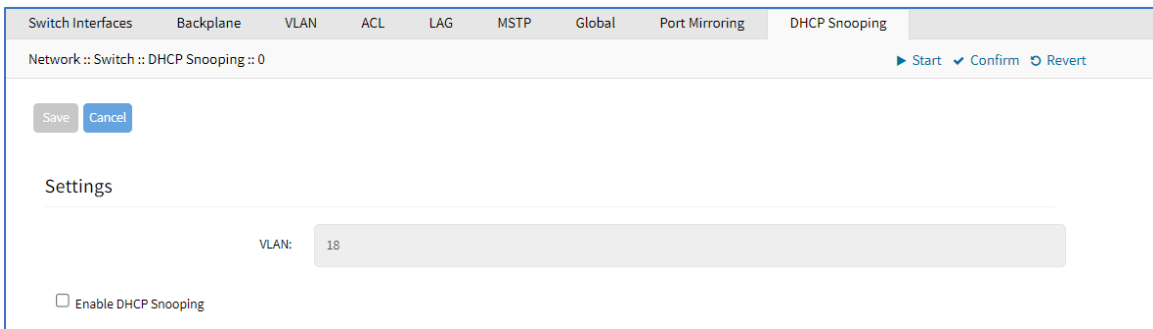

Select **Enable DHCP Snooping** (expands dialog).

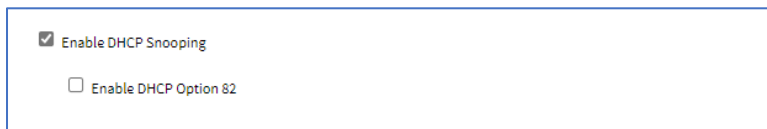

Select **Enable DHCP Option 82** (expands dialog).

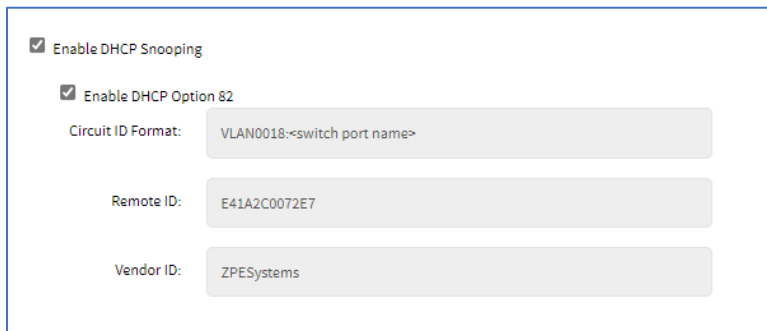

Review details.

4. If changes made, click **Save**.

## Disable DHCP Snooping

1. Go to *Network :: Switch :: DHCP Snooping*.
2. Select a checkbox with an enabled VLAN.
3. Click **Edit** (displays dialog).

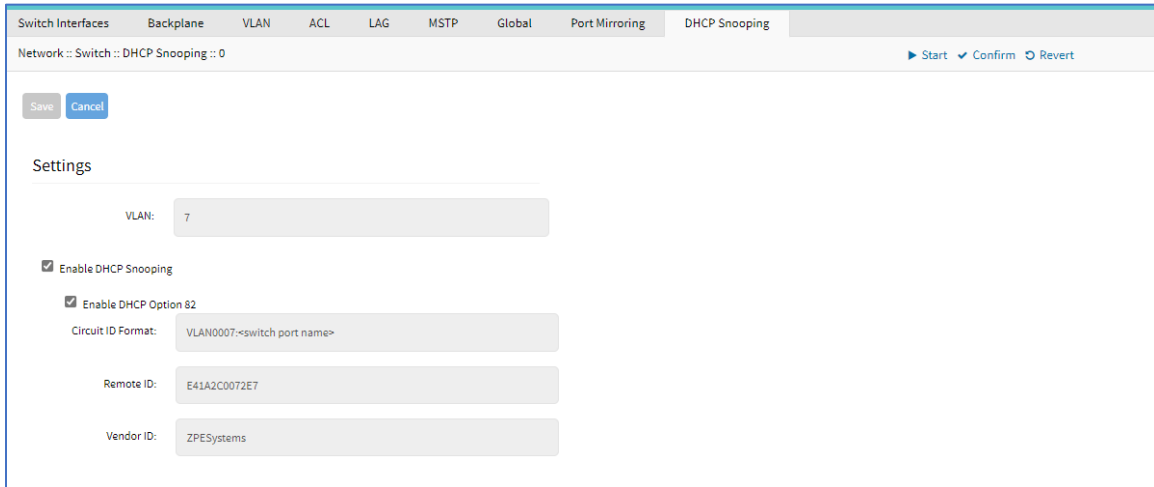

Unselect **Enable DHCP Snooping** (expands dialog).

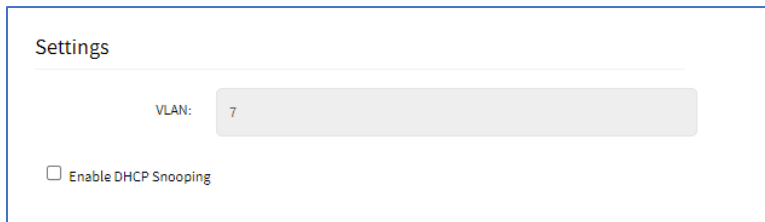

4. If changes made, click **Save**.

## Static Routes tab

Administrators can define and manage static routes. Routes can be created for IPv4 and IPv6, assigned to specific network interfaces.

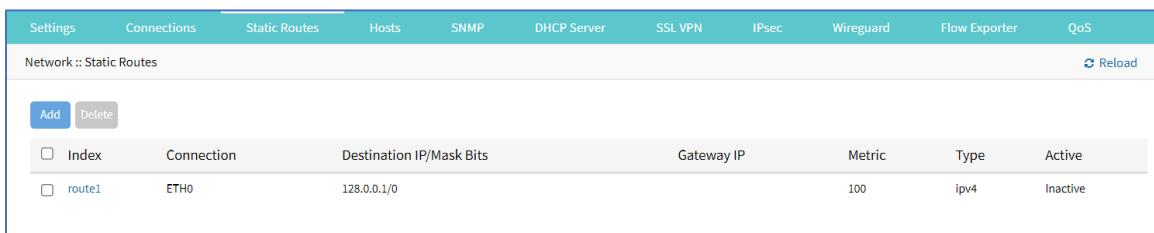

## Manage Static Routes

### Add Static Route

#### WebUI Procedure

1. Go to *Network :: Static Routes*.
2. Click **Add** (displays dialog).

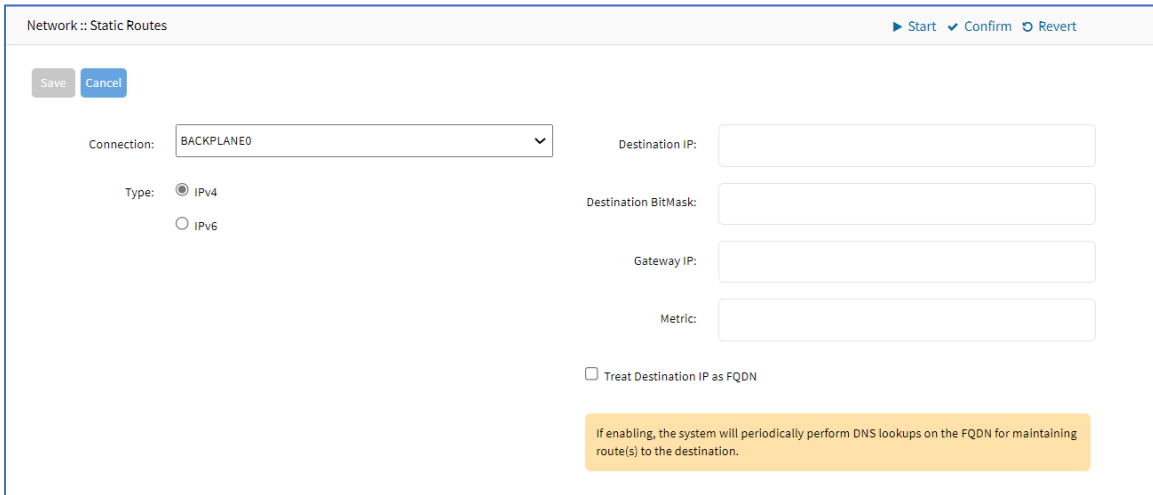

3. On **Connection** drop-down, select one (**ETH0, ETH1, hotspot**).
4. In *Type* menu, select one:
  - IPv4** radio button.
  - IPv6** radio button.
5. Enter **Destination IP**.
6. Enter **Destination BitMask**.
7. Enter **Gateway IP**.
8. Enter **Metric** (routing metric value – for normal routes, default = 100)
9. Select **Treat Destination IP as FQDN** checkbox (closes **Destination BitMask** field).
10. Click **Save**.

## Edit Static Route

### WebUI Procedure

1. Go to *Network :: Static Routes*.
2. In the *Index* column, click on the name (displays dialog).
3. Make changes as needed.
4. Click **Save**.

## Delete Static Route

### WebUI Procedure

1. Go to *Network :: Static Routes*.



2. In the list, select a checkbox.
3. Click **Delete**.

## Hosts tab

Administrators can configure and manage manual hostname definitions (equivalent to entries in the host's file).

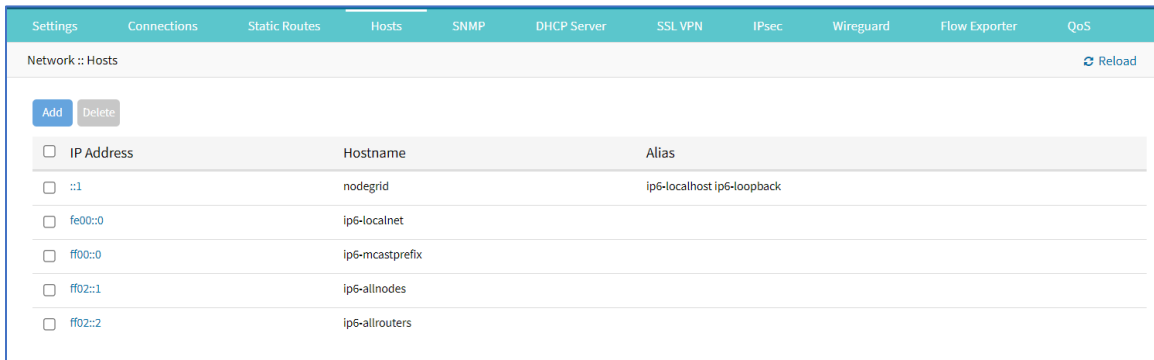

## Manage Hosts

### Add Host

#### WebUI Procedure

1. Go to *Network :: Hosts*.
2. Click **Add** (displays dialog).

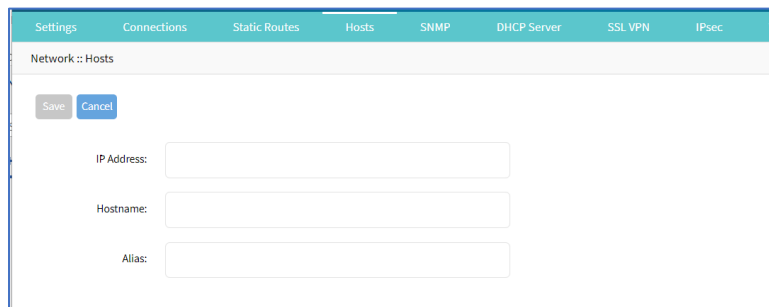

3. Enter **IP Address** (IPv4, IPv6 formats supported.)
4. Enter **Hostname**.
5. Enter **Alias**.
6. Click **Save**.

### Edit Host

#### WebUI Procedure

1. Go to *Network :: Hosts*.

2. In the *Index* column, click on the name (displays dialog).
3. Make changes as needed.
4. Click **Save**.

## Delete Host

### WebUI Procedure

1. Go to *Network :: Hosts*.
2. In the list, select a checkbox.
3. Click **Delete**.

## SNMP tab

Administrators can configure SNMP settings here.

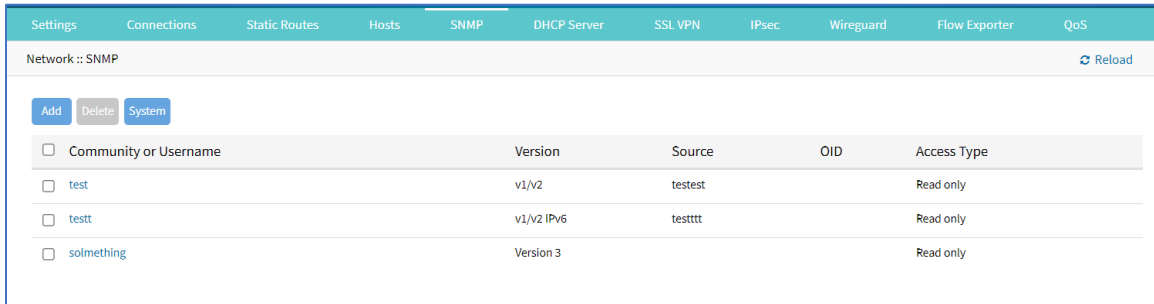

<input type="checkbox"/>	Community or Username	Version	Source	OID	Access Type
<input type="checkbox"/>	test	v1/v2	testest		Read only
<input type="checkbox"/>	testt	v1/v2 IPv6	testttt		Read only
<input type="checkbox"/>	solomething	Version 3			Read only

## Manage SNMP

### Review/edit System Information

#### WebUI Procedure

1. Go to *Network :: SNMP*.
2. Click **System** (displays dialog).

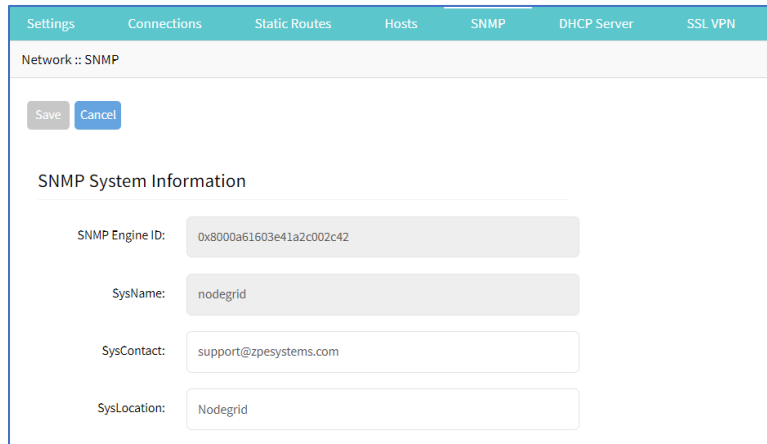

Network :: SNMP

Save Cancel

SNMP System Information

SNMP Engine ID: 0x8000a61603e41a2c002c42

SysName: nodegrid

SysContact: support@zpesystems.com

SysLocation: Nodegrid

3. Two fields can be edited:  
**SysContact** (email address)  
**SysLocation** (location name)
4. If changed, click **Save**.
5. If not, click **Cancel** to return to table.

## Add SNMP Community/Username Configuration

### WebUI Procedure

1. Go to *Network :: SNMP*.
2. Click **Add** (displays dialog).

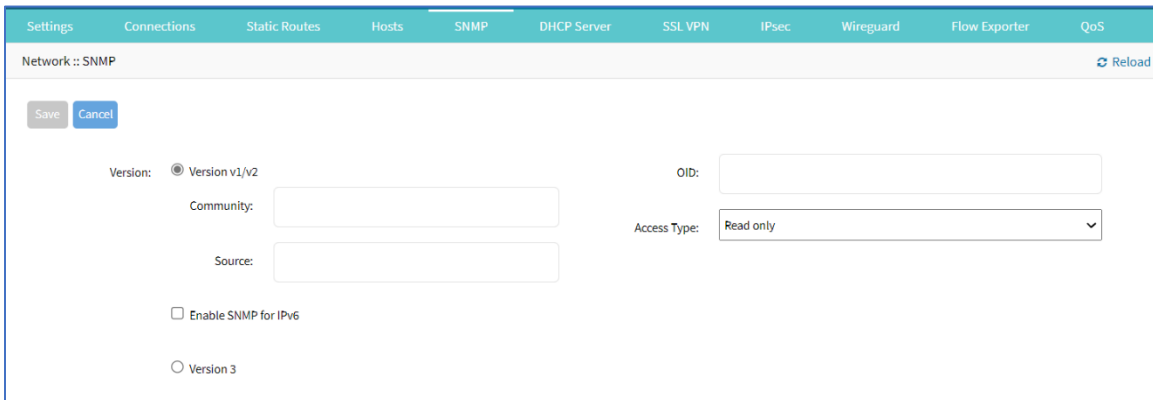

The screenshot shows the 'Network :: SNMP' configuration dialog. At the top, there are navigation tabs: Settings, Connections, Static Routes, Hosts, **SNMP**, DHCP Server, SSL VPN, IPsec, Wireguard, Flow Exporter, and QoS. Below the tabs, there are 'Save' and 'Cancel' buttons. The main configuration area includes:

- Version:** Radio buttons for 'Version v1/v2' (selected) and 'Version 3'.
- Community:** A text input field.
- Source:** A text input field.
- Enable SNMP for IPv6:** A checkbox.
- OID:** A text input field.
- Access Type:** A dropdown menu currently set to 'Read only'.

3. In *Version* menu (select one):  
**Version V1/V2** radio button.  
Enter **Community**.  
Enter **Source**.  
(if applicable) Select **Enable SNMP for IPv6** checkbox.

**Version 3** radio button (expands dialog).

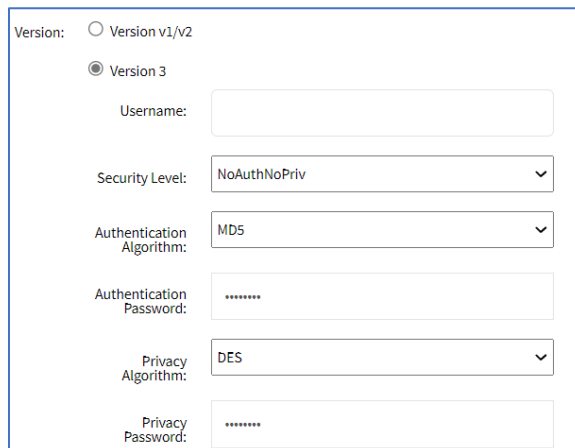

The expanded dialog for 'Version 3' includes the following fields:

- Version:** Radio buttons for 'Version v1/v2' and **'Version 3'** (selected).
- Username:** A text input field.
- Security Level:** A dropdown menu set to 'NoAuthNoPriv'.
- Authentication Algorithm:** A dropdown menu set to 'MD5'.
- Authentication Password:** A text input field with masked characters (dots).
- Privacy Algorithm:** A dropdown menu set to 'DES'.
- Privacy Password:** A text input field with masked characters (dots).

Enter **Username**.

On **Security** Level drop-down, select one (**NoAuthNoPriv**, **AuthNoPriv**, **AuthPriv**).

On **Authentication Algorithm** drop-down, select one (**MD5**, **SHA**, **SHA-224**, **SHA-256**, **SHA-384**, **SHA-512**).

Enter **Authentication Password**.

On **Privacy Algorithm** drop-down, select one (**DES**, **AES**, **AES-192**, **AES-256**).

Enter **Privacy Password**.

4. Enter **OID**.
5. On **Access Type** drop-down, select one (**Read and Write**, **Read Only**).
6. Click **Save**.

## Edit Community/Username

### WebUI Procedure

1. Go to *Network :: SNMP*.
2. On *Community or Username* column, click a name (displays dialog).
3. Make changes, as needed.
4. Click **Save**.

## Delete Community/Username

### WebUI Procedure

1. Go to *Network :: SNMP*.
2. Select checkbox to be deleted.
3. Click **Delete**.

## Wireless Modem tab

This provides details on the Wireless Modem (if installed).

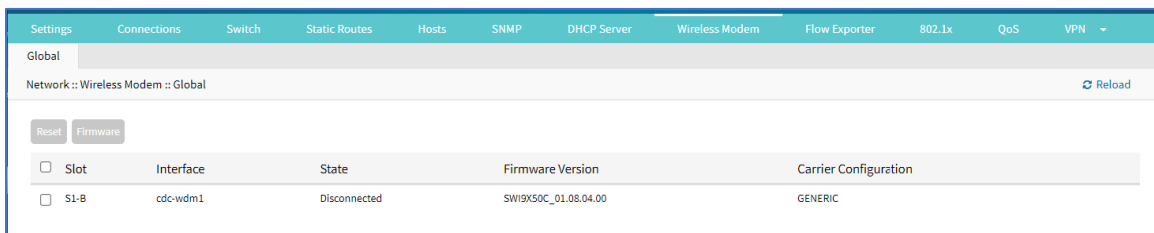

Slot	Interface	State	Firmware Version	Carrier Configuration
<input type="checkbox"/> S1-B	cdc-wdm1	Disconnected	SW19X50C_01.08.04.00	GENERIC

## Manage Wireless Modem

### Reset Wireless Model

#### WebUI Procedure

1. Go to *Network :: Wireless Modem*.
1. Select checkbox next to *Slot* name.
2. Click **Reset**.

## Manage Wireless Modem Firmware

### WebUI Procedure

1. Go to *Network :: Wireless Modem*.
2. Select checkbox next to *Slot* name.
3. Click **Firmware** (displays dialog).

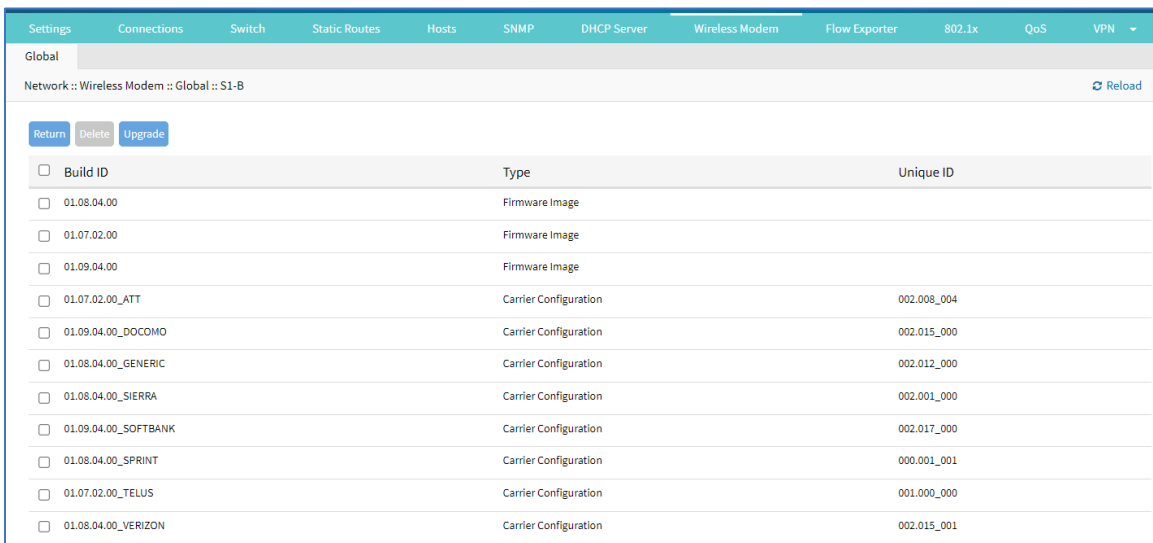

Build ID	Type	Unique ID
<input type="checkbox"/> 01.08.04.00	Firmware Image	
<input type="checkbox"/> 01.07.02.00	Firmware Image	
<input type="checkbox"/> 01.09.04.00	Firmware Image	
<input type="checkbox"/> 01.07.02.00_ATT	Carrier Configuration	002.008_004
<input type="checkbox"/> 01.09.04.00_DOCOMO	Carrier Configuration	002.015_000
<input type="checkbox"/> 01.08.04.00_GENERIC	Carrier Configuration	002.012_000
<input type="checkbox"/> 01.08.04.00_SIERRA	Carrier Configuration	002.001_000
<input type="checkbox"/> 01.09.04.00_SOFTBANK	Carrier Configuration	002.017_000
<input type="checkbox"/> 01.08.04.00_SPRINT	Carrier Configuration	000.001_001
<input type="checkbox"/> 01.07.02.00_TELUS	Carrier Configuration	001.000_000
<input type="checkbox"/> 01.08.04.00_VERIZON	Carrier Configuration	002.015_001

4. To delete firmware:
  - Select checkbox next to *Build ID*.
  - Click **Delete**.
5. To upgrade firmware.
  - Select checkbox next to *Build ID*.
  - Click **Upgrade** (displays dialog).

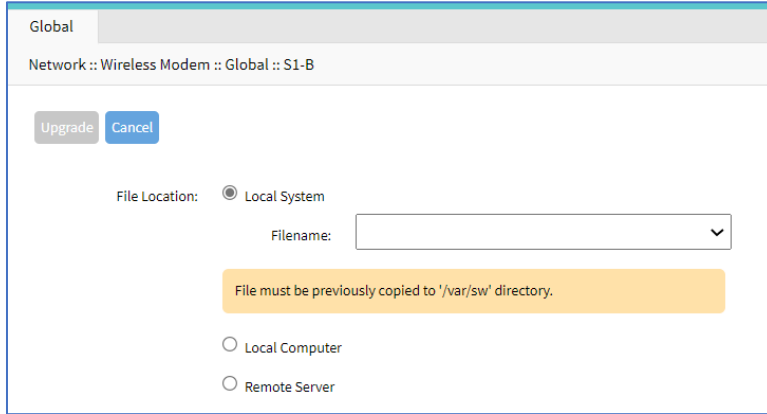

In *File Location* menu, select one:

Select **Local Computer** radio button (expands dialog).

Click **Choose File**. Locate and select the file.

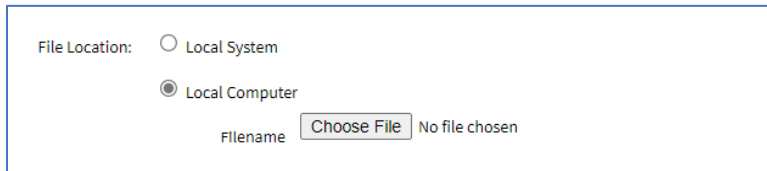

Select **Remote Server** radio button (expands dialog).

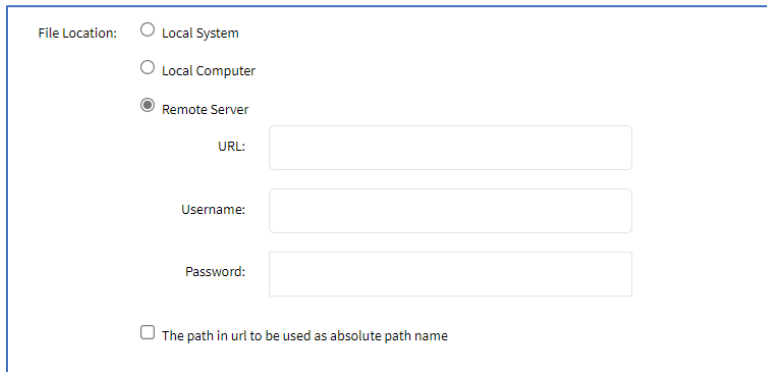

Enter **URL**.

Enter **Username**.

Enter **Password**.

(optional) Select **The path in url to be used as absolute path name** checkbox.

6. Click **Upgrade**.

## Flow Exporter tab

Netflow streaming telemetry data is supported for all network interfaces, including the switch interface.

Network :: Flow Exporter						
Name	Status	Collector	Sampling Rate	Interfaces	Aggregation Fields	
<input type="checkbox"/> Flow2	Error	192.168.56.2:2055	1/12	eth0,eth1	dst_host,dst_port,proto,src_host,src_mac,src_mask,src_port,tos	
<input type="checkbox"/> Flow3	Disabled	192.168.56.3:2055	1/1	eth0	dst_host,dst_port,proto,src_host,src_port,tos	
<input type="checkbox"/> MyFlow	Running	127.0.0.1:2055	1/1	eth0	dst_host,dst_port,proto,src_host,src_port,tos	

## Add a new Flow Export

### WebUI Procedure

1. Go to *Network :: Flow Exporter*.
2. Click **Add** (displays dialog).

Network :: Flow Exporter :: New ▶ Start ✓ Confirm ↺ Revert

#### Settings

Name:

Enabled

Interface:

Collector Address:

Collector Port:

Protocol:

Active Timeout (s):

Inactive Timeout (s):

Sampling Rate (1 out of N):

#### Aggregation Fields

Aggregation  
 Ethernet CoS, 802.1P  
 Ethernet Ethertype  
 Source MAC address  
 Destination MAC address  
 Ethernet VLAN, 802.1Q  
 Source network mask  
 Destination network mask  
 Source IPv4/IPv6 prefix

Source IPv4/IPv6 address  
 Destination IPv4/IPv6 address  
 IP protocol  
 IP ToS  
 Source TCP/UDP port  
 Destination TCP/UDP port

3. In *Settings* menu:
  - Enter **Name**.
  - Select **Enabled** checkbox.
  - On **Interface** drop-down, select one (**eth0**, **eth1**).
  - Enter **Collector Address**.
  - Enter **Collector Port** (default: 2055).
  - On **Protocol** drop-down, select one (**IPFIX**, **NetFlow v9**, **NetFlow v5**).
  - Enter **Active Timeouts (s)** in seconds (default: 60).
  - Enter **Inactive Timeout (s)** in seconds (default: 15).

Enter **Sampling Rate (1 out of N)** (default: 1).

4. In *Aggregation Fields* menu:

To add an item to the *Aggregation*:

Select item on left-side panel.

Click **Add▶** (item is moved).

To remove an item from the *Aggregation*:

Select item on right-side panel.

Click **◀Remove** (item is moved).

5. Click **Save**.

## 802.1x tab (Net SR only)

These functions are only available on Nodegrid Net SR device.

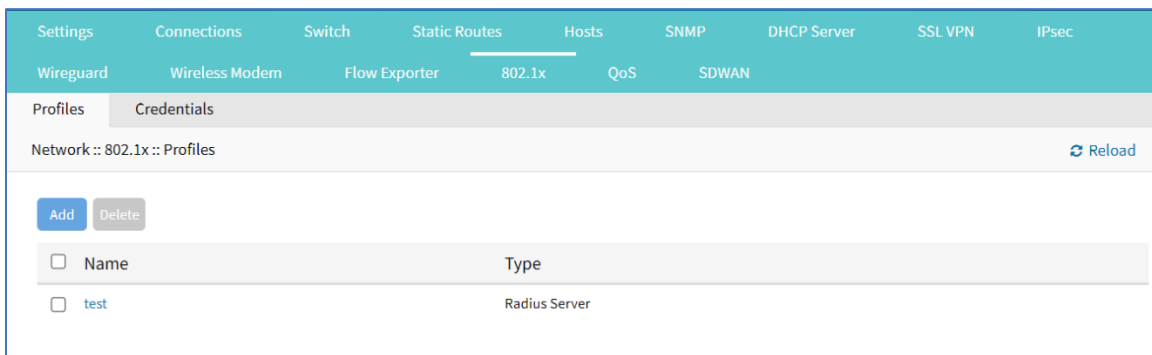

### Profiles sub-tab

#### Add Profile

1. Go to *Network :: 802.1x :: Profile*.
2. Click **Add** (displays dialog).



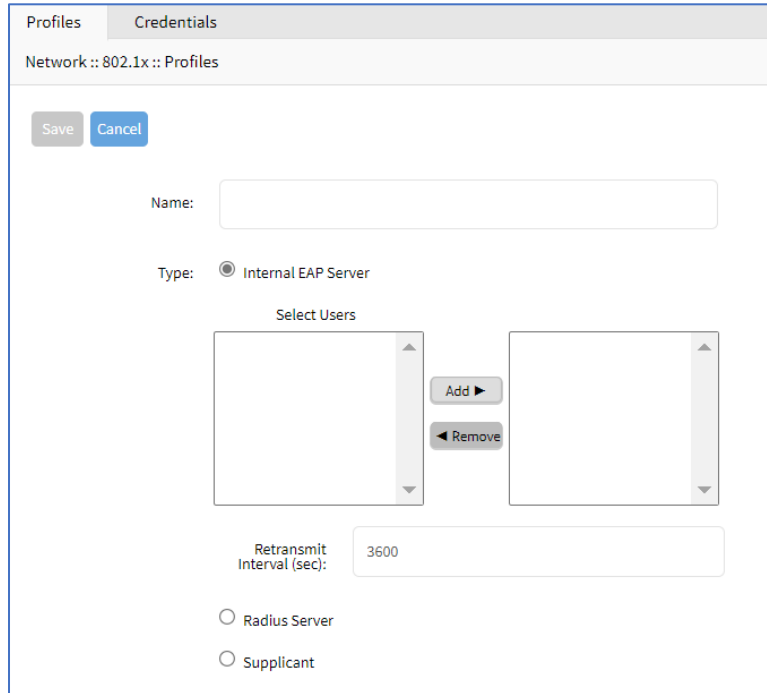

3. Enter **Name**.
4. On *Type* menu, select one:  
**Internal EAP Server** radio button (expands dialog).

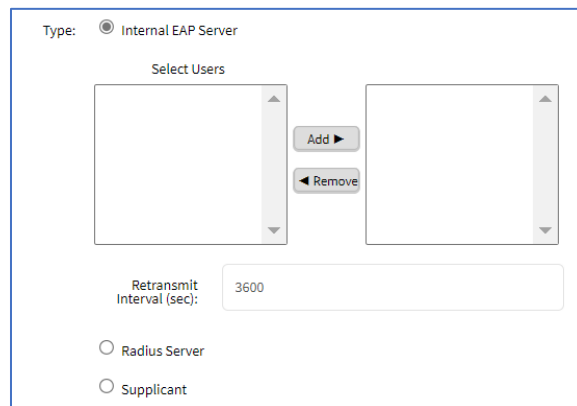

In *Select Users*:

To add, select item on left-side panel and click **Add ►** (item is moved).

To remove, select item on right-side panel and click **◀ Remove** (item is moved).

Enter **Retransmit Interval (sec)** (default: 3600).

**Radius Server** radio button (expands dialog).

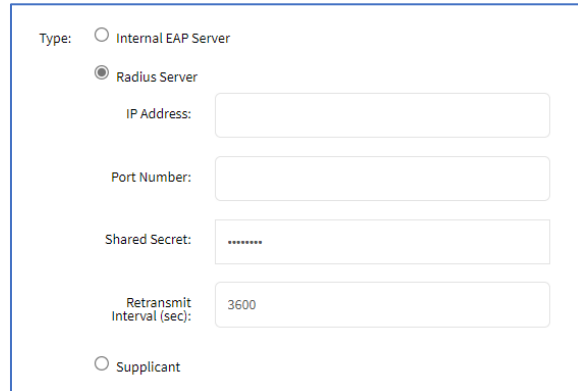

Enter **IP Address**.

Enter **Port Number**.

Enter **Shared Secret**.

Enter **Retransmit Interval (sec)**.

**Supplicant** radio button (expands dialog). On **User** drop-down, select one.

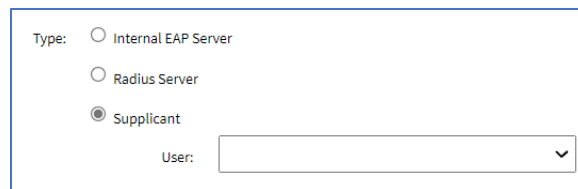

5. Click **Save**.

## Edit a Profile

### WebUI Procedure

1. Go to *Network :: 802.1x :: Profile*.
2. In the *Name* column, click on a name (opens dialog).
3. Make changes, as needed.
4. Click **Save**.

## Delete an Interface

### WebUI Procedure

1. Go to *Network :: 802.1x :: Profile*.
2. Select checkbox to be deleted.
3. Click **Delete**.
4. On confirmation pop-up dialog, click **OK**.

## Credentials sub-tab

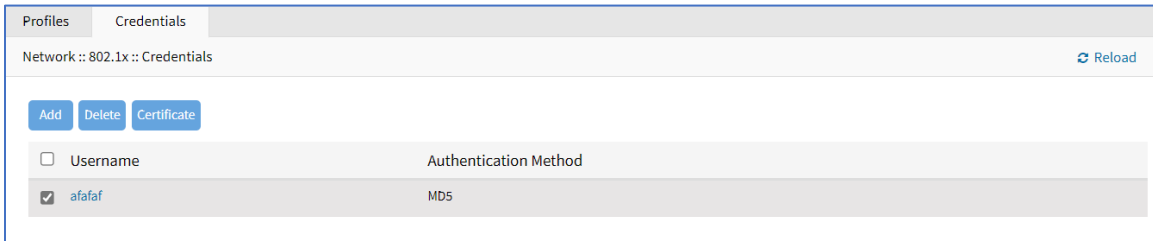

### Add Credential

#### WebUI Procedure

1. Go to *Network :: 802.1x :: Credentials*.
2. Click **Add** (displays dialog).

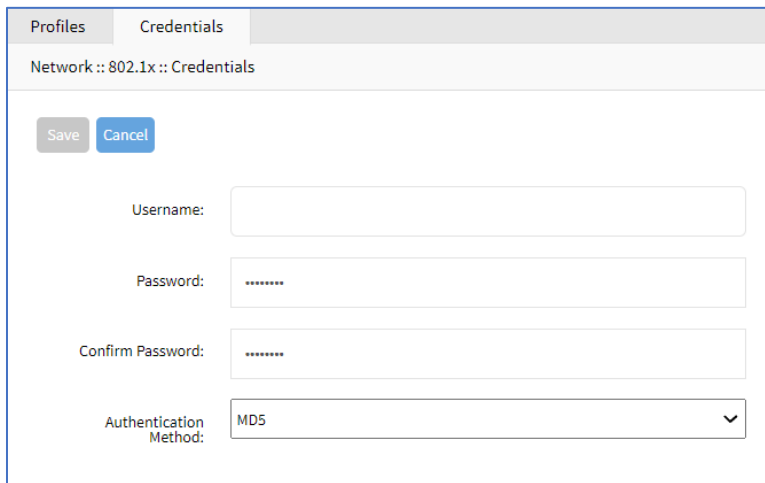

3. Enter **Username**.
4. Enter **Password** and **Confirm Password**.
5. On **Authentication** drop-down, select one (**MD5, TLS, PEAP, TTLS**).
6. Click **Save**.

### Edit Credential

#### WebUI Procedure

1. Go to *Network :: 802.1x :: Credentials*.
2. In *Username* column, click on name (opens dialog).
3. Make changes, as needed.
4. Click **Save**.

### Delete Credential

#### WebUI Procedure

1. Go to *Network :: 802.1x :: Credentials*.
2. Select checkbox.
3. Click **Delete**.
4. On confirmation pop-up dialog, click **OK**.

## Include Certificate

### WebUI Procedure

1. Go to *Network :: 802.1x :: Credentials*.
2. Select checkbox.
3. Click **Certificate** (displays dialog). User must have TLS authentication.

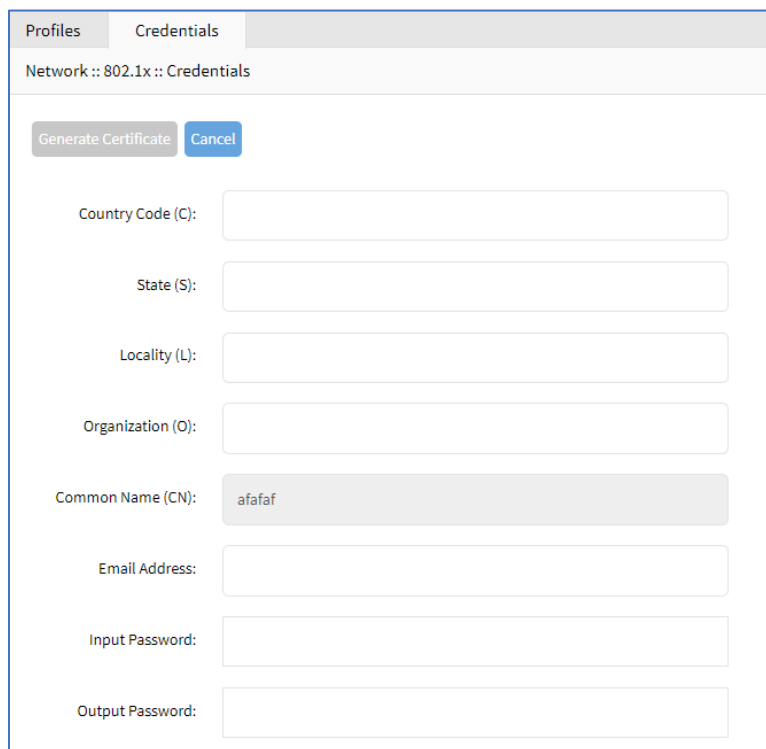

Profiles Credentials

Network :: 802.1x :: Credentials

Generate Certificate Cancel

Country Code (C):

State (S):

Locality (L):

Organization (O):

Common Name (CN): afafaf

Email Address:

Input Password:

Output Password:

4. Enter the following details:

**Country Code (C)**

**State (S)**

**Locality (L)**

**Organization (O)**

**Email Address**

**Input Password**

**Output Password**

5. Click **Generate Certificate** (displays dialog).

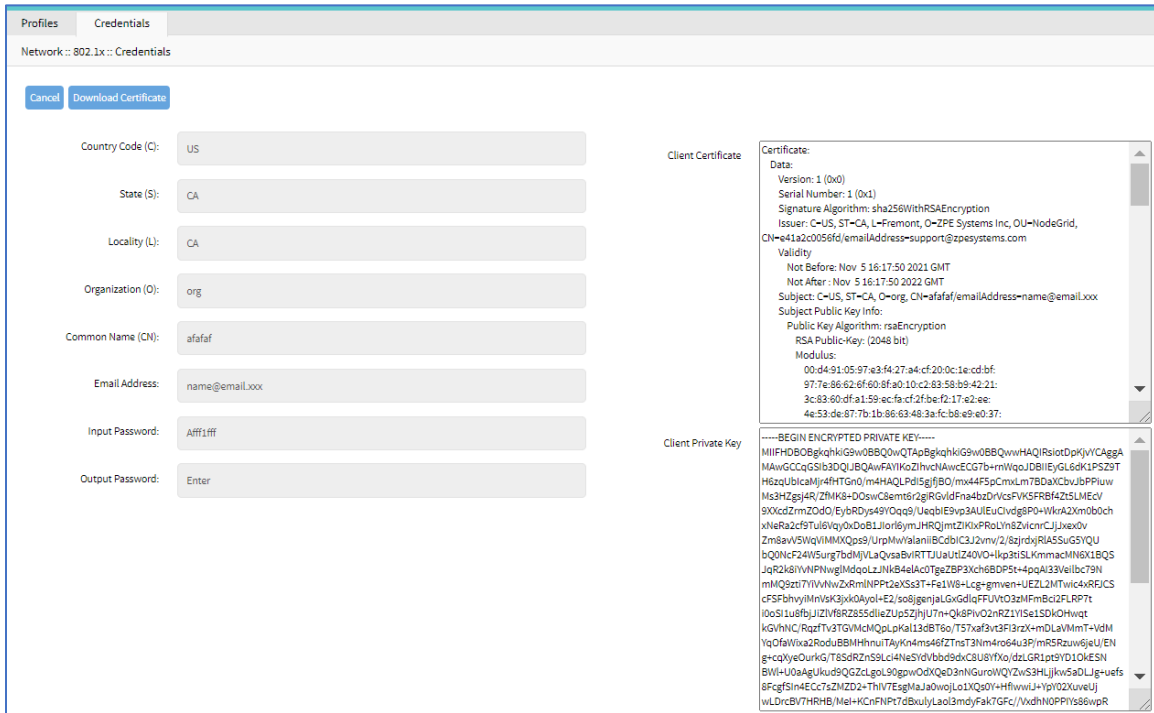

6. Click **Download Certificate**.

7. On pop-up dialog, click **Allow**.

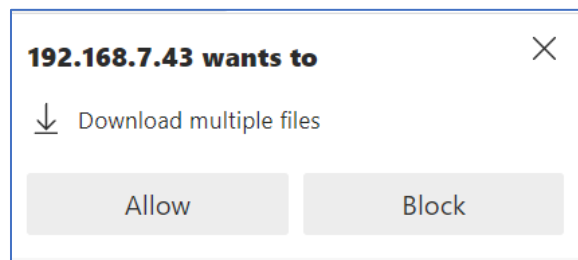

8. Certificate is saved to the local computer download location.

## QoS tab

QoS (Quality of Service) rules can be configured. Three configuration levels are available: Interface, Classes, Rules.

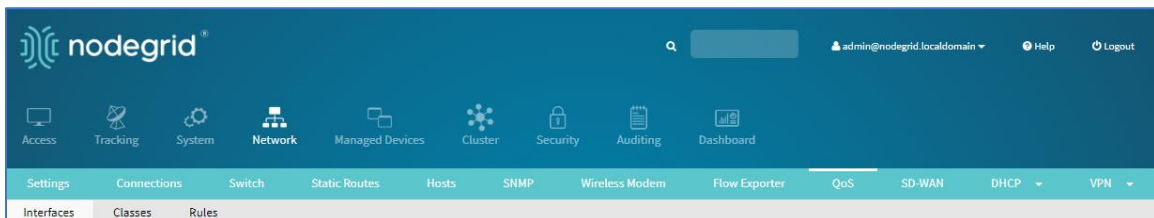

## Interfaces sub-tab

The Interface tab allows you to Add, Edit, Delete, and Enable/Disable QoS on each available interface. The main table displays information regarding the Name, Status, Direction, and Classes for each interface.

**NOTE:** Status can be Disabled, Running, or Error

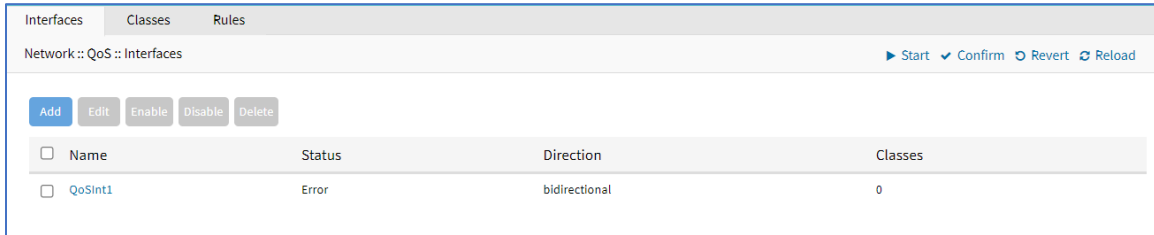

Name	Status	Direction	Classes
QoSInt1	Error	bidirectional	0

## Add an Interface

### WebUI Procedure

1. Go to *Network :: QoS :: Interfaces*.
2. Click **Add** (displays dialog).

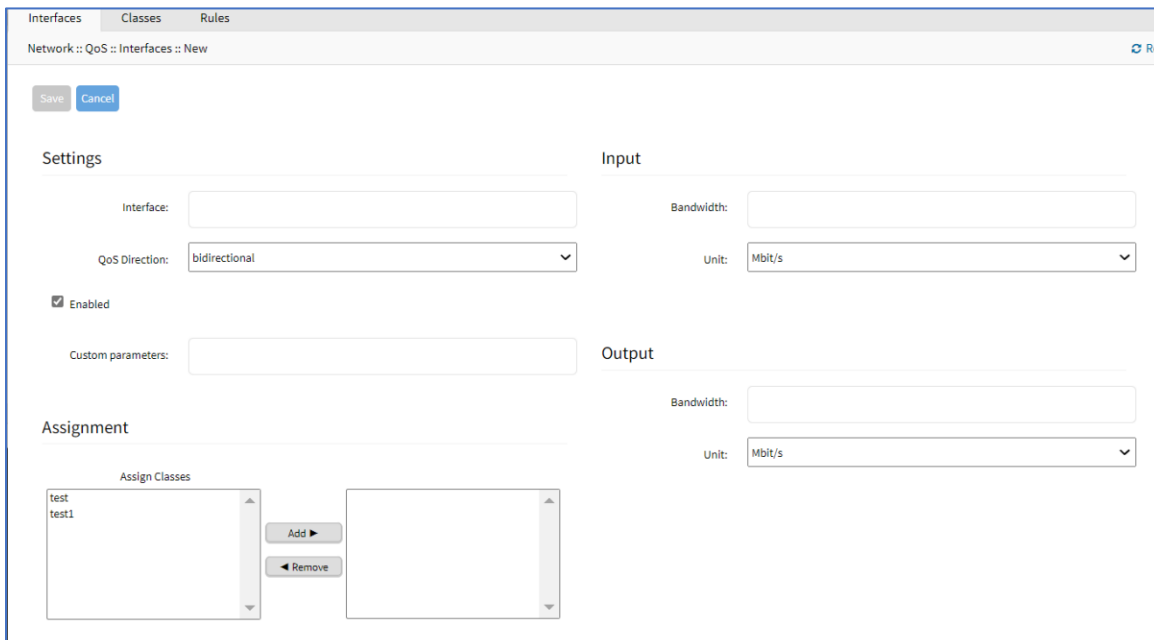

3. In *Settings* menu:
  - Enter **Interface** (must match existing interface name).
  - On **QoS Direction** drop-down, select one (**Input**, **Output**, **Bidirectional**).
  - Select **Enabled** checkbox.
4. Enter **Custom parameters** (advanced users only – enter FireQOS commands).
5. In *Assignment* menu:

To add a Class:

Select item on left-side panel.

Click **Add▶** (item is moved).

To remove a Class:

Select item on right-side panel.

Click **◀Remove** (item is moved).

6. In *Input* menu: (Input menu details must match Output menu details)

Enter **Bandwidth**.

On **Unit** drop-down, select one (**GB/s, MB/s, KB/s, B/s, Gbit/s, Mbit/s, Kbit/s, bit/s**).

7. In *Output* menu:

Enter **Bandwidth**.

On **Unit** drop-down, select one (**GB/s, MB/s, KB/s, B/s, Gbit/s, Mbit/s, Kbit/s, bit/s**).

8. Click **Save**.

## Edit an Interface

### WebUI Procedure

1. Go to *Network :: QoS :: Interfaces*.
2. In the *Name* column, locate and select checkbox,
3. Click **Edit** (opens dialog).
4. Make changes, as needed.
5. Click **Save**.

## Delete an Interface

### WebUI Procedure

1. Go to *Network :: QoS :: Interfaces*.
2. Select checkbox to be deleted.
3. Click **Delete**.
4. On confirmation pop-up dialog, click **OK**.

## Enable/Disable an Interface

### Enable Interface

1. Go to *Network :: QoS :: Interfaces*.
2. Select checkbox to be enabled.
3. Click **Enable**.

### Disable Interface

1. Go to *Network :: QoS :: Interfaces*.
2. Select checkbox to be disabled.
3. Click **Disable**.

### Classes sub-tab

This manages QoS classes.

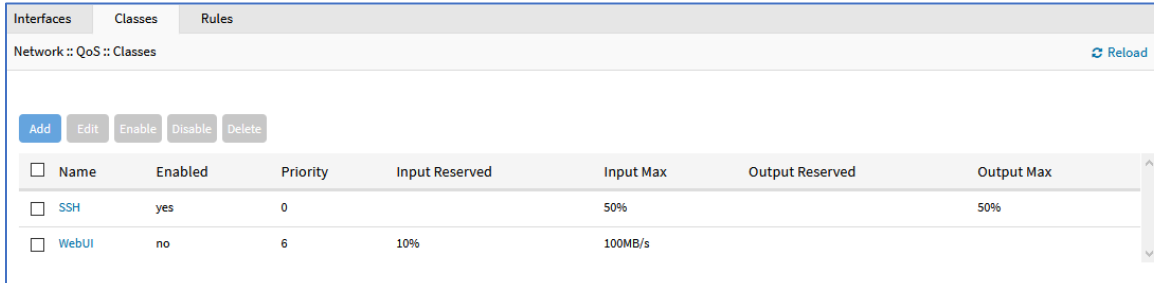

<input type="checkbox"/>	Name	Enabled	Priority	Input Reserved	Input Max	Output Reserved	Output Max
<input type="checkbox"/>	SSH	yes	0		50%		50%
<input type="checkbox"/>	WebUI	no	6	10%	100MB/s		

### Add a Class

#### WebUI Procedure

1. Go to *Network :: QoS :: Classes*.
2. Click **Add** (displays dialog).

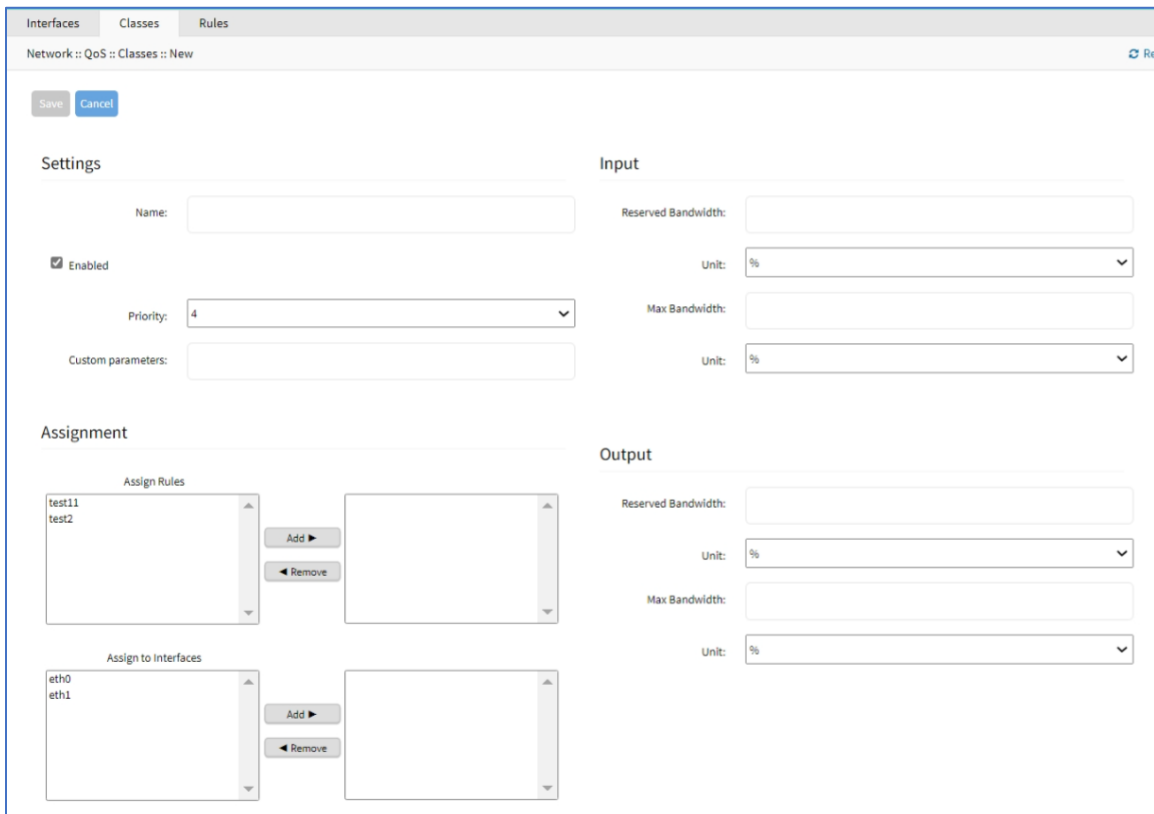



3. In *Settings* menu:

Enter **Name** (descriptive name for this class).

Select **Enabled** checkbox.

On **Priority** drop-down, select one (**0, 1, 2, 3, 4, 5, 6, 7**) (0=highest priority).

4. In *Assignment* menu:

In *Assign Rules*:

To add a Rule:

**NOTE:** If multiple rules are added, they are applied as OR (for example, if two rules are added, whichever rule applies is the rule used for the class).

Select item on left-side panel.

Click **Add▶** (item is moved).

To remove a Rule:

Select item on right-side panel.

Click **◀Remove** (item is moved).

To add an Interface:

Select item on left-side panel.

Click **Add▶** (item is moved).

To remove an Interface:

Select item on right-side panel.

Click **◀Remove** (item is moved).

5. In *Input* menu: (Input menu details must match Output menu details)

Enter **Reserved Bandwidth**.

On **Unit** drop-down, select one (**%, GB/s, MB/s, KB/s, B/s, Gbit/s, Mbit/s, Kbit/s, bit/s**).

Enter **Max Bandwidth**.

On **Unit** drop-down, select one (**%, GB/s, MB/s, KB/s, B/s, Gbit/s, Mbit/s, Kbit/s, bit/s**).

6. In *Output* menu:

Enter **Reserved Bandwidth**.

On **Unit** drop-down, select one (**%, GB/s, MB/s, KB/s, B/s, Gbit/s, Mbit/s, Kbit/s, bit/s**).

Enter **Max Bandwidth**.

On **Unit** drop-down, select one (**%, GB/s, MB/s, KB/s, B/s, Gbit/s, Mbit/s, Kbit/s, bit/s**).

7. Click **Save**.

**NOTE:** The “Input” and “Output” sections only apply to interfaces with that corresponding direction. For example, if a class has “Input” and “Output” limits but is assigned to an interface with “output”, only “Output” limits apply.

## Edit a Class

### WebUI Procedure

1. Go to *Network :: QoS :: Classes*.
2. In the *Name* column, locate and select checkbox,
3. Click **Edit** (opens dialog).
4. Make changes, as needed.
5. Click **Save**.

## Delete a Class

### WebUI Procedure

1. Go to *Network :: QoS :: Classes*.
2. Select checkbox to be deleted.
3. Click **Delete**.

## Enable/Disable a Class

### WebUI Procedure

1. Go to *Network :: QoS :: Classes*.
2. Select checkbox to be enabled/disabled.
3. Click **Enable** (to enable class).
4. Click **Disable** (to disable class).

## Rules sub-tab

Customer QoS rules are managed with these actions: Add, Edit, Enable/Disable, and Delete. The main table contains information on existing rules.



<input type="checkbox"/>	Name	Enabled
<input type="checkbox"/>	SSHdst	yes
<input type="checkbox"/>	SSHsrc	yes
<input type="checkbox"/>	WebUI_dst	yes

## Add a Rule

### WebUI Procedure

1. Go to *Network :: QoS :: Rules*.
2. Click **Add** (displays dialog).

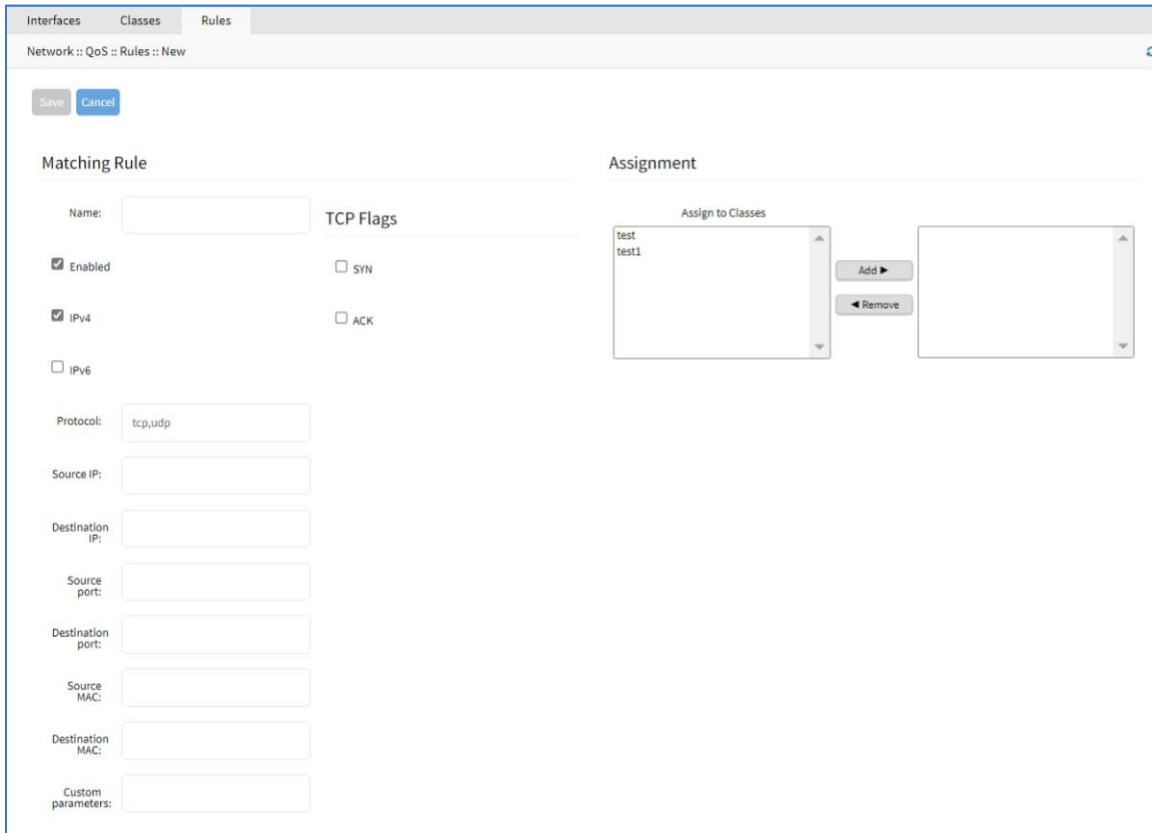

3. In *Matching Rule* menu:
4. Enter **Name** (descriptive name for this rule).

Select **Enabled** checkbox.

Select **IPv4** checkbox.

Select **IPv6** checkbox.

Enter **Protocol**.

**NOTE:** Options for "Protocol" include the majority of protocol types. Entry can be by protocol number or lower-case protocol keyword. Multiple protocols can be input using comma-separated entries. Official source is at [Internet Assigned Numbers Authority](#).

Enter **Source IP**.

Enter **Destination IP**.

Enter **Source Port**.

Enter **Destination Port**.

Enter **Source MAC**.

Enter **Destination MAC**.

Enter **Custom parameters** (advanced users only – enter FireQoS commands).

5. In *TCP Flags* menu:

Select **SYN** checkbox.

Select **ACK** checkbox.

6. In *Assignment* menu:

To add a Class:

Select item on left-side panel.

Click **Add▶** (item is moved).

To remove a Class:

Select item on right-side panel.

Click **◀Remove** (item is moved).

7. Click **Save**.

**NOTE:** All parameters in a rule will be applied as an “AND” operation.

For fields that support multiple values, enter comma separated values. Numeric fields support ranges, separated with a dash (i.e., 22-100).

## Edit a Rule

### WebUI Procedure

1. Go to *Network :: QoS :: Rules*.
2. In the *Name* column, locate and select checkbox,
3. Click **Edit** (opens dialog).
4. Make changes, as needed.
5. Click **Save**.

## Delete a Rule

### WebUI Procedure

1. Go to *Network :: QoS :: Rules*.
2. Select checkbox to be deleted.
3. Click **Delete**.
4. On confirmation pop-up dialog, click **OK**.

## Enable/Disable a Rule

### Enable Rule

1. Go to *Network :: QoS :: Rules*.
2. Select checkbox to be enabled.
3. Click **Enable**.

### Disable Rule

1. Go to *Network :: QoS :: Rules*.
2. Select checkbox to be disabled.
3. Click **Disable**.

## SD-WAN tab

ZPE recommends working with SD-WAN only with the ZPE Cloud application. Modifying directly on the Nodegrid device loses synchronization with ZPE Cloud.

### Application sub-tab

Go to *Network :: SD-WAN :: Application*.

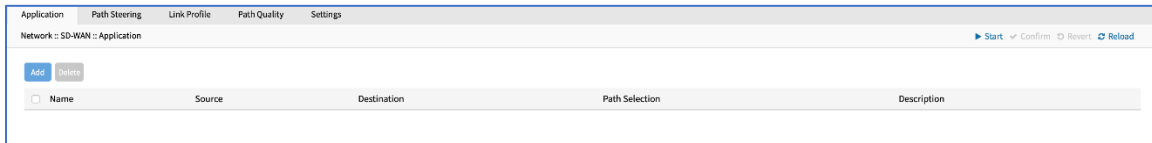

### Add Application

1. Go to *Network :: SD-WAN :: Application*.
2. Click **Add** (displays dialog).

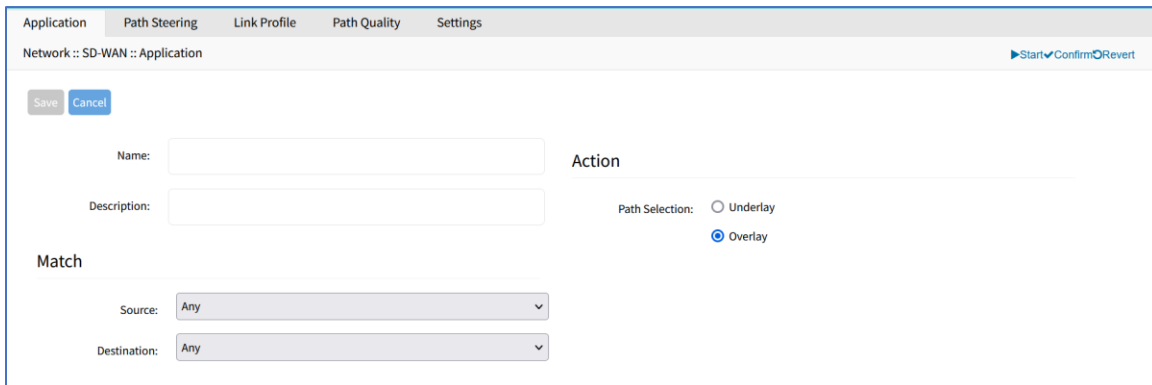

3. Enter **Name**.
4. Enter **Description**.
5. In *Match* menu:

On **Source** drop-down, select one (**Any, Custom**)

If **Custom** (expands dialog)

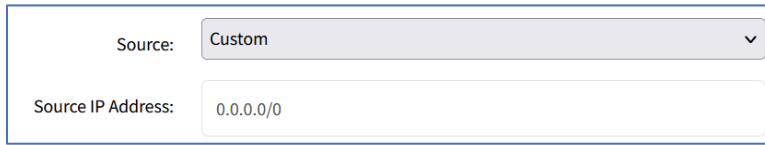

A screenshot of a configuration dialog box. At the top, there is a dropdown menu labeled 'Source:' with 'Custom' selected. Below it is a text input field labeled 'Source IP Address:' containing the value '0.0.0.0/0'.

Enter **Source IP Address**.

On **Destination** drop-down, select one (**Any, Custom**)

If **Custom** (expands dialog)

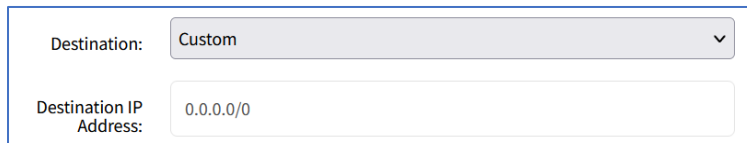

A screenshot of a configuration dialog box. At the top, there is a dropdown menu labeled 'Destination:' with 'Custom' selected. Below it is a text input field labeled 'Destination IP Address:' containing the value '0.0.0.0/0'.

Enter **Destination IP Address**.

6. In *Action* menu, select one:

**Underlay** radio button

**Overlay** radio button

7. Click **Save**.

### **Path Steering sub-tab**

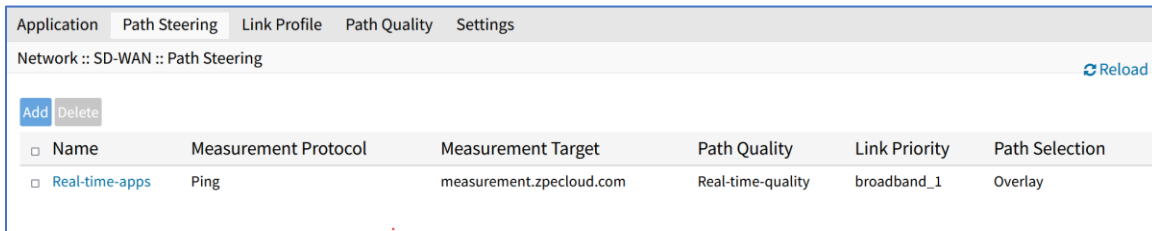

A screenshot of the Path Steering sub-tab interface. At the top, there are tabs for 'Application', 'Path Steering', 'Link Profile', 'Path Quality', and 'Settings'. Below the tabs, the text 'Network :: SD-WAN :: Path Steering' is displayed, followed by a 'Reload' button. There are 'Add' and 'Delete' buttons. Below these is a table with the following data:

Name	Measurement Protocol	Measurement Target	Path Quality	Link Priority	Path Selection
Real-time-apps	Ping	measurement.zpecloud.com	Real-time-quality	broadband_1	Overlay

### **Add Path Steering**

8. Go to *Network :: SD-WAN :: Path Steering*.

9. Click **Add** (displays dialog).

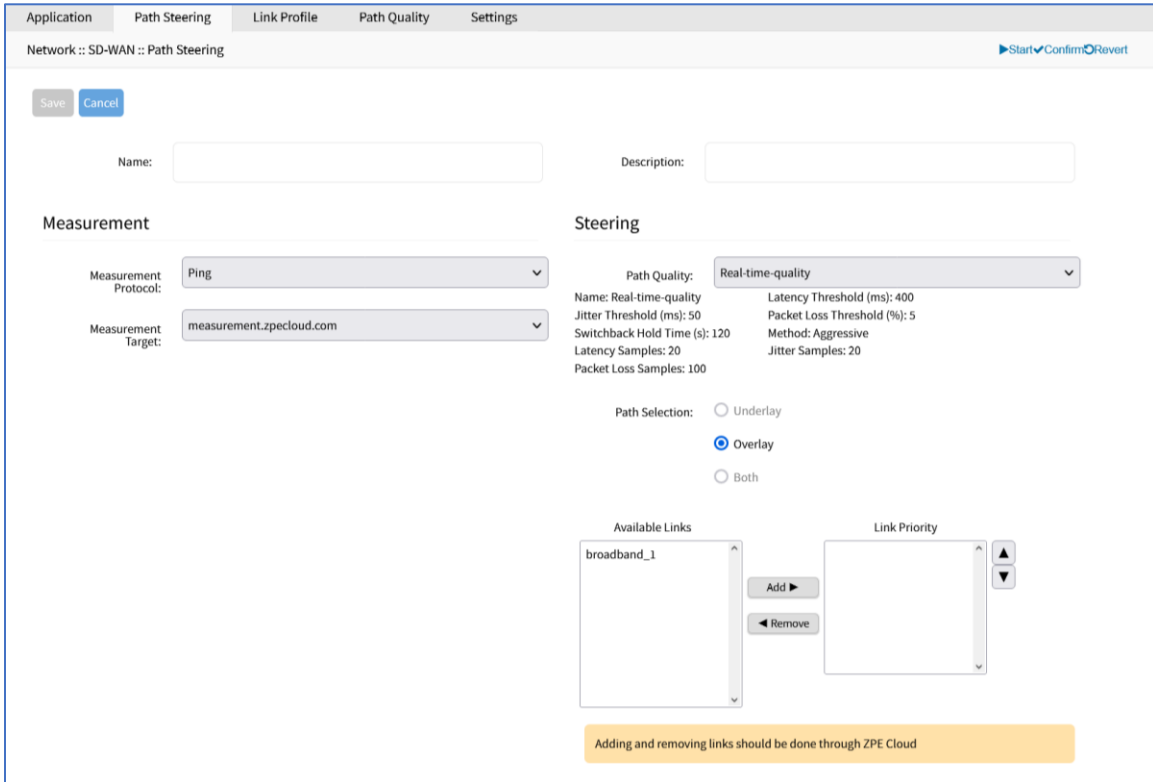

10. Enter **Name**.

11. Enter **Description**.

12. In *Measurement* menu:

On **Measurement Protocol** drop-down, select one (**Ping**);

On **Measurement Target** drop-down, select one.

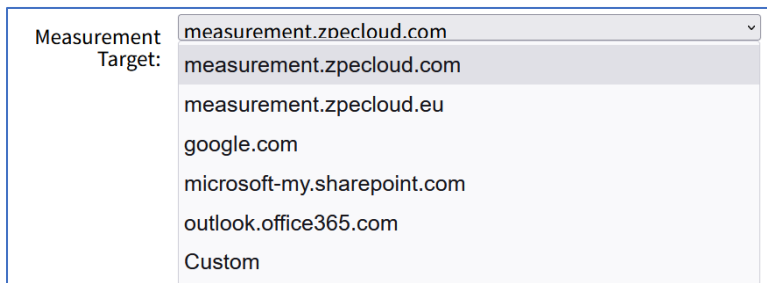

If **Custom** (expands dialog), enter **Measurement Target IP Address or FQDN**.

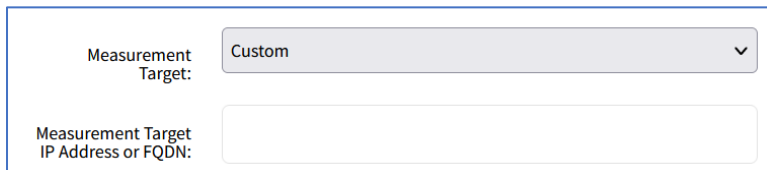

13. In *Steering* menu:

On **Path Quality** drop-down, select one.

On **Port Selection**, select one.

**Underlay** radio button

**Overlay** radio button

**Both** radio button

In *Available Links* section:

**NOTE:** If device is enrolled in ZPE Cloud, these links should be changed on the ZPE Cloud application.

Select from left-side panel, click **Add▶** to move to right-side panel.

To remove from right-side panel, select, and click **◀Remove**.

14. Click **Save**.

### Edit Path Steering

1. Go to *Network :: SD-WAN :: Path Steering*.
2. Click on **Name**.
3. Make changes, as needed.
4. Click **Save**.

### Delete Path Steering

1. Go to *Network :: SD-WAN :: Path Steering*.
2. Select checkbox next to **Name**.
3. Click **Delete**.
4. On confirmation dialog, click **OK**.

### Link Profile sub-tab

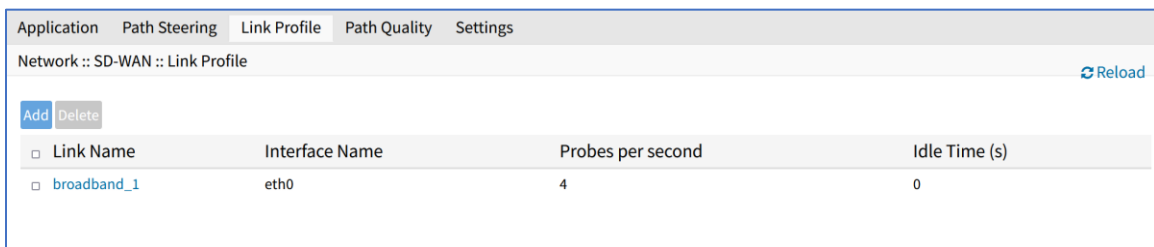

Link Name	Interface Name	Probes per second	Idle Time (s)
<input type="checkbox"/> broadband_1	eth0	4	0

### Add Link Profile

#### WebUI Procedure

1. Go to *Network :: SD-WAN :: Link Profile*.
1. Click **Add** (displays dialog).



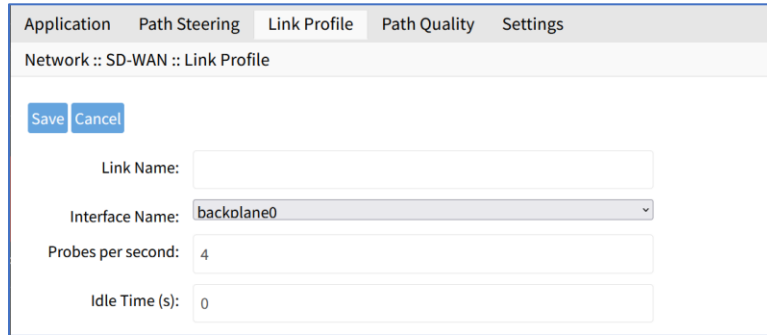

2. Enter **Link Name**.
3. On **Interface Name** drop-down, select one.
4. Enter **Probes per second** (default: 4).
5. Enter **Idle Time**. (seconds) (default: 0).
6. Click **Save**.

## Edit Link Profile

### WebUI Procedure

1. Go to *Network :: SD-WAN :: Link Profile*.
1. In **Name** column, click on name.
2. Make changes, as needed.
3. Click **Save**.

## Delete Link Profile

### WebUI Procedure

1. Go to *Network :: SD-WAN :: Link Profile*.
1. Select checkbox to be deleted.
2. Click **Delete**.
3. On confirmation pop-up dialog, click **OK**.

## Path Quality sub-tab

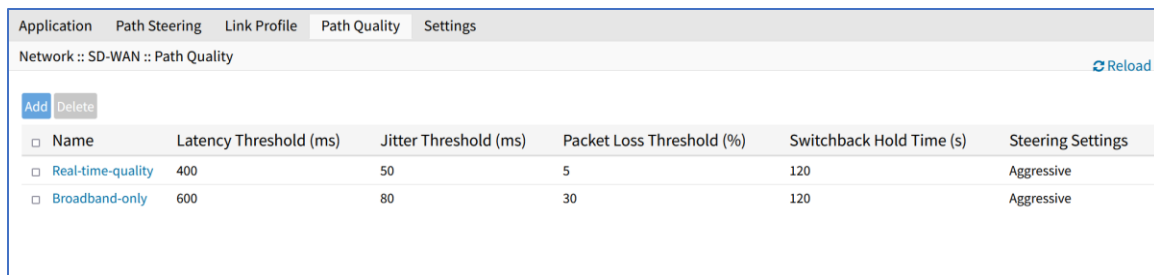

<input type="checkbox"/>	Name	Latency Threshold (ms)	Jitter Threshold (ms)	Packet Loss Threshold (%)	Switchback Hold Time (s)	Steering Settings
<input type="checkbox"/>	Real-time-quality	400	50	5	120	Aggressive
<input type="checkbox"/>	Broadband-only	600	80	30	120	Aggressive

## Add Path Quality

### WebUI Procedure

1. Go to *Network :: SD-WAN :: Link Profile*.
2. Click **Add** (displays dialog).

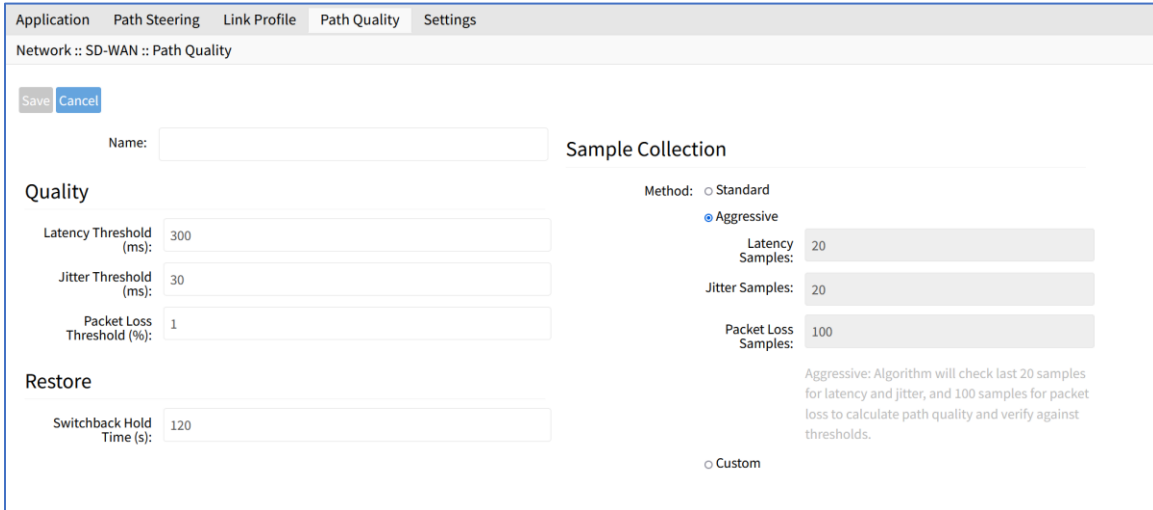

3. Enter **Name**.
4. In *Quality* menu:
  - Enter **Latency Threshold (ms)** (default: 300)
  - Enter **Jitter Threshold (ms)** (default: 30)
  - Enter **Packet Loss Threshold (%)** (default: 1)
5. In *Restore* menu:
  - Enter **Switchback Hold Time (s)** (default: 120)
6. In *Sample Collection* menu:
  - On **Method**, select one:
    - Standard** radio button (fields are read-only):
      - Latency Samples** (default: 50)
      - Jitter Samples** (default: 50)
      - Packet Loss Samples** (default: 100)
    - Aggressive** radio button (fields are read-only):
      - Latency Samples** (default: 50)
      - Jitter Samples** (default: 50)
      - Packet Loss Samples** (default: 100)
    - Custom** radio button: (fields are editable)

Enter **Latency Samples**

Enter **Jitter Samples**

Enter **Packet Loss Samples**

7. Click **Save**.

## Edit Path Quality

### WebUI Procedure

1. Go to *Network :: SD-WAN :: Path Quality*.
2. In **Name** column, click on name.
3. Make changes, as needed.
4. Click **Save**.

## Delete Path Quality

### WebUI Procedure

1. Go to *Network :: SD-WAN :: Path Quality*.
2. Select checkbox to be deleted.
3. Click **Delete**.
4. On confirmation pop-up dialog, click **OK**.

## Settings sub-tab

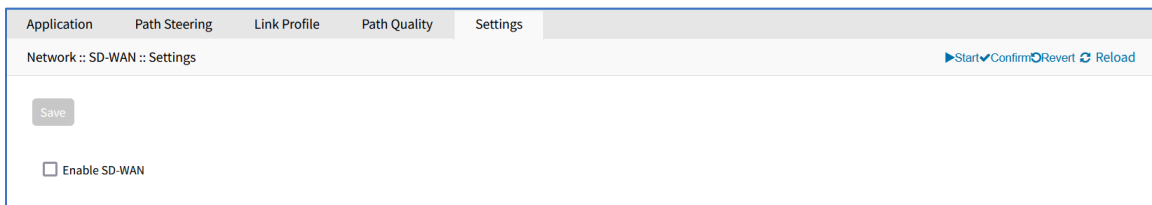

## Enable SD-WAN

The minimum Nodegrid supported version to enable SD-WAN is v5.4.6+.

### WebUI Procedure

1. Go to *Network :: SD-WAN :: Settings*.
2. Select **Enable SD-WAN**.
3. Click **Save**.

## DHCP drop-down > DHCP Server tab

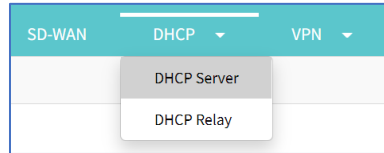

The DHCP server for devices can be configured and managed. By default, the DHCP server is not configured or active. When a DHCP scope is defined, the system serves IP addresses to all devices connected to the interface and which match the general DHCP scope.

Configuration is a two-step process. First, the general DHCP scope and configuration is configured and created. Then, IP address ranges (Network Range) are defined to be used as server IP addresses and as IP address reservations for specific hosts.

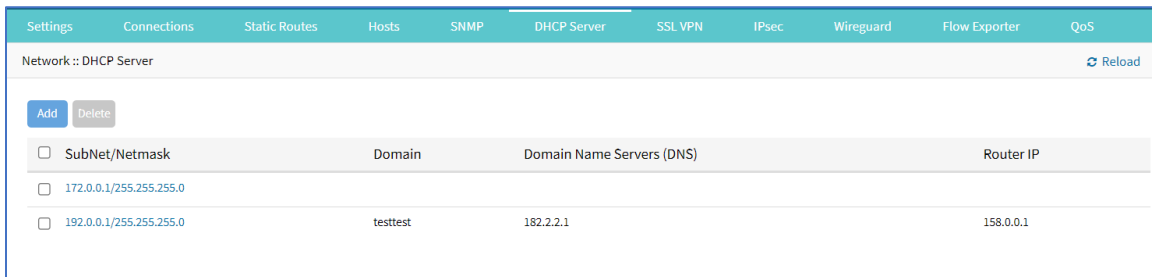

### Manage DHCP Server

#### Add DHCP Server

##### WebUI Procedure

1. Go to *Network :: DHCP drop-down :: DHCP Server*.
2. Click **Add** (displays dialog):

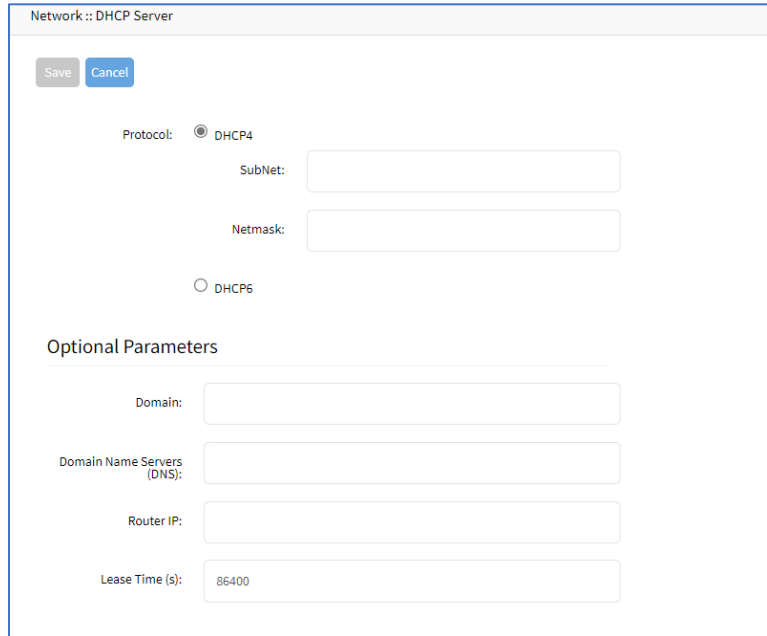

3. On *Protocol* menu, select one:

**DHCP4** radio button (expands dialog):

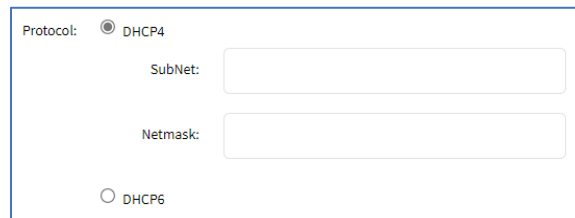

Enter **Subnet** (must match the settings of a configured interface)

Enter **Netmask** (defined subnet – format: xxx.xxx.xxx.xxx)

**DHCP6** radio button (expands dialog):

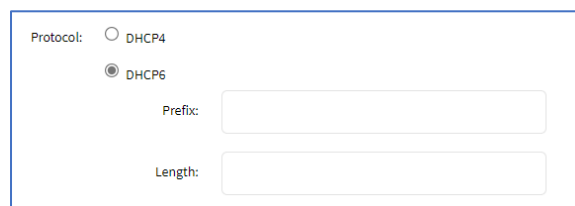

Enter **Prefix**

Enter **Length**

4. In *Optional Parameters* menu:

Enter **Domain**

Enter **Domain Name Services (DNS)**

Enter **Router IP** (DHCP4 only)

Enter **Lease Time (s)** (default: 86400).

5. Click **Save**.

## Edit DHCP Server Configuration

### WebUI Procedure

1. Go to *Network :: DHCP drop-down :: DHCP Server*.
2. On *Subnet/Netmask* column, click a name.
3. On **Settings** sub-tab.

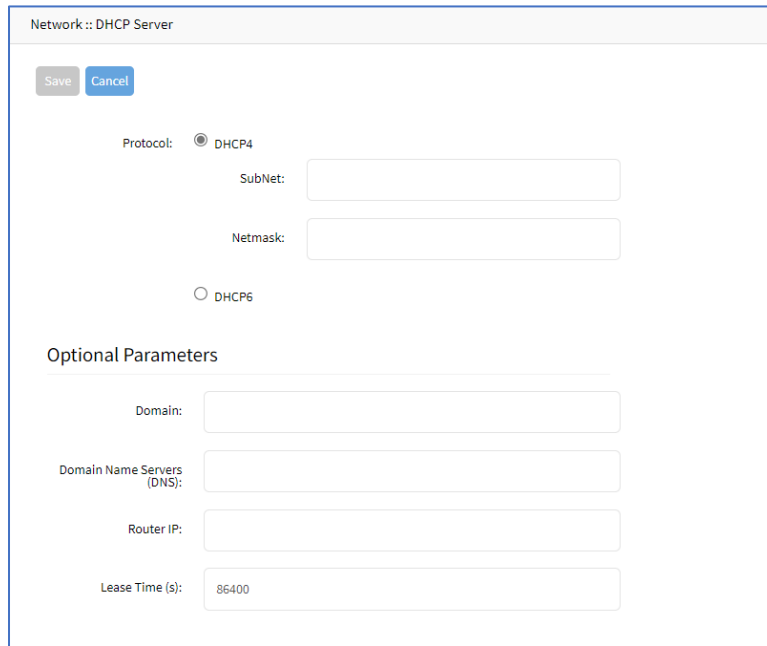

Make changes as needed.

Click **Save**.

4. On **Network Range** sub-tab:

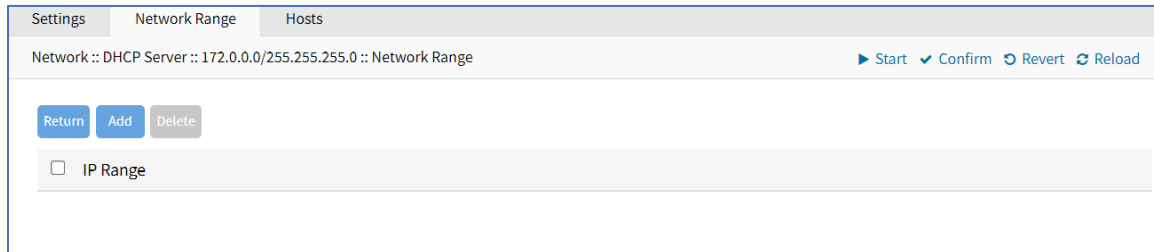

To add a network range, click **Add** (displays dialog).

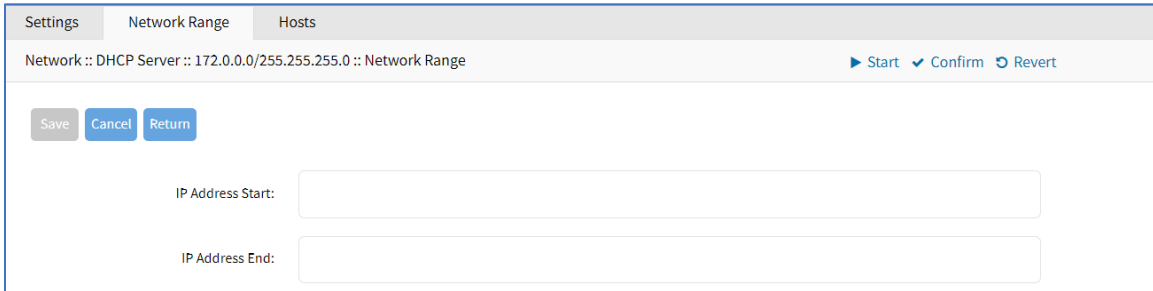

Enter **IP Address Start** (first IP address to be served).

Enter **IP Address End** (last IP address to be served).

Click **Save**.

To edit a network range, click on the **IP Range** (expands dialog).

Make changes, as needed.

Click **Save**.

To delete a network range, select the *IP Range* checkbox.

Click **Delete**.

5. On **Hosts** sub-tab:

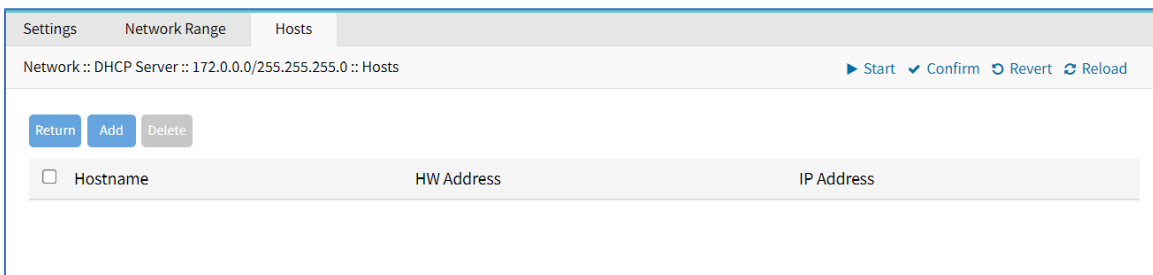

Hostname	HW Address	IP Address
<input type="checkbox"/>		

To add a host, click **Add** (displays dialog).

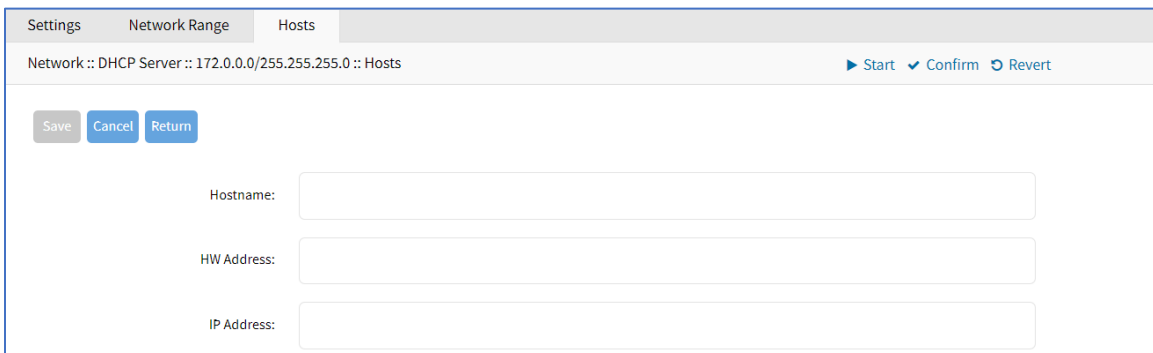

Enter **Hostname**.

Enter **HW Address**.

Enter **IP Address**.

Click **Save**.

To edit a host, click on the **Hostname** (expands dialog).

Make changes, as needed.

Click **Save**.

To delete a host, select the Hostname checkbox.

Click **Delete**.

6. Click **Save**.

## Delete DHCP Server

### WebUI Procedure

1. Go to *Network :: DHCP drop-down :: DHCP Server*.
2. Select checkbox to be deleted.
3. Click **Delete** (displays confirmation dialog).
4. Click **OK**.

## Edit DHCP Server Settings, IP Range, and Hosts

### WebUI Procedure

1. Go to *Network :: DHCP drop-down :: DHCP Server*.
2. In the *Subnet/Netmask* column, click name (displays dialog).

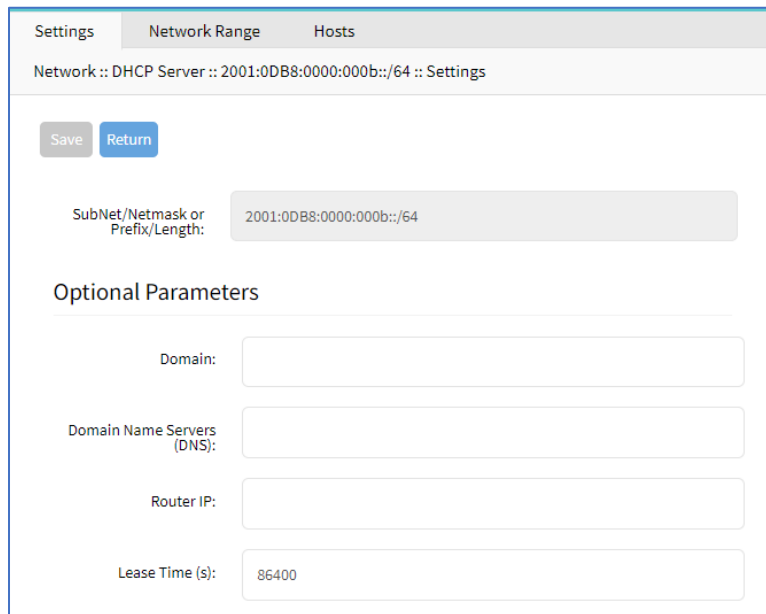

3. On **Settings** sub-tab, review details.

Make changes, as needed.



4. Click on **Network Range** sub-tab (displays dialog).

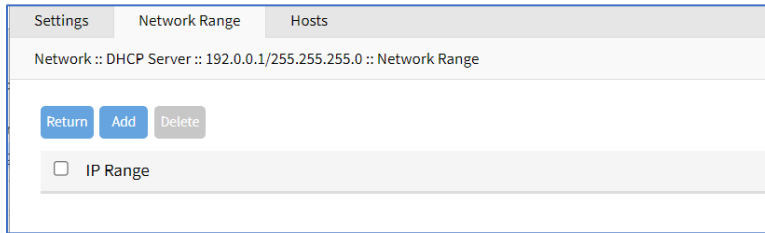

To add IP Range:

Click **Add** (displays dialog).

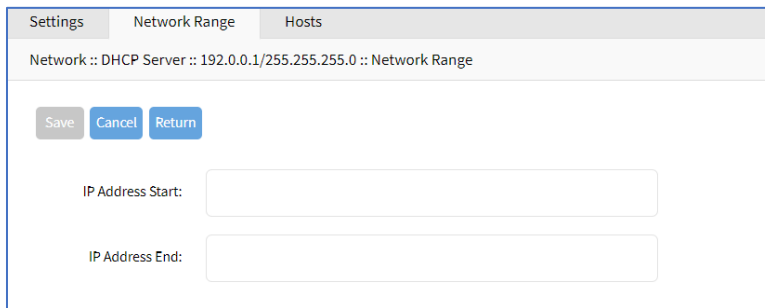

Enter **IP Address Start** (first IP address to be served).

Enter **IP Address End** (last IP address to be served).

Click **Save**.

To edit IP Range

In column, click on *IP Range* name.

Make changes, as needed.

Click **Save**.

To delete IP Range

Select checkbox next to name.

Click **Delete**.

5. Click on **Hosts** sub-tab (displays dialog)

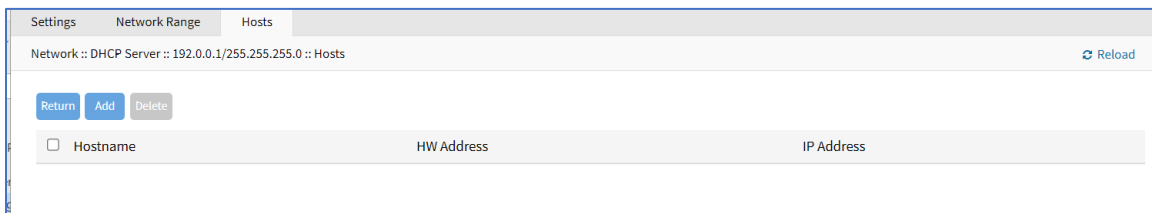

To add a host:

Click **Add** (opens dialog)

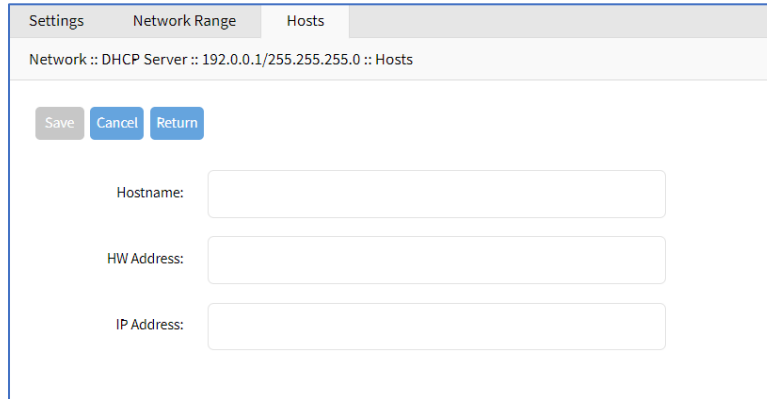

Enter **Hostname**

Enter **HW Address**. (MAC address to which an IP address reservation applies)

Enter **IP Address** (IP address assigned to specific host matching the MAC address)

Click **Save**

To edit host:

In *Host* column, click on name

Make changes, as needed.

Click **Save**

To delete host:

In Host column, select checkbox

Click **Delete**

## DHCP drop-down > DHCP Relay tab

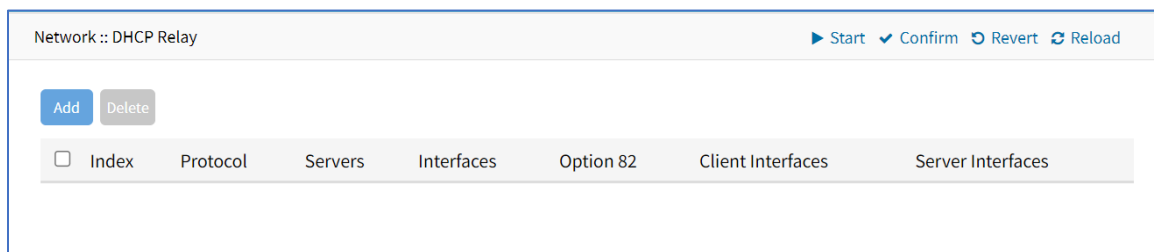

### Manage DHCP Relay

#### Add DHCP Relay

1. Go to *Network :: DHCP drop-down :: DHCP Relay*.
2. Click **Add** (displays dialog).

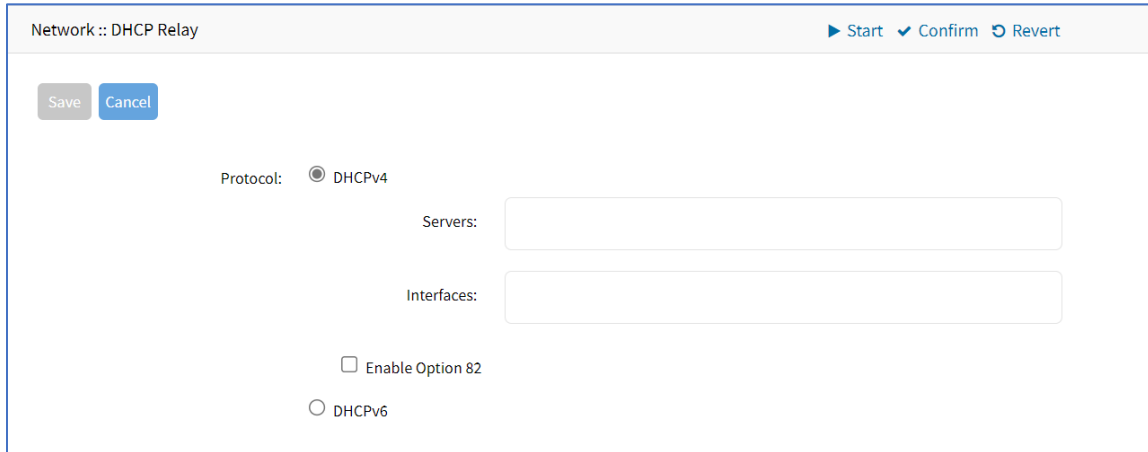

3. In *Protocol* menu, select one:

**DHCPv4** radio button.

Enter **Servers**.

(optional) Enter **Interfaces**.

Select **Enable Option** (expands dialog).

On **Incoming Option 82 Policy** drop-down, select one (**Replace Option 82, Append Option 82, Forward Packet, Discard Packet**).

**DHCPv6** radio button.

Enter **Server Interfaces**.

Enter **Client Interfaces**.

4. Click **Save**.

### Edit DHCP Relay

1. Go to *Network :: DHCP drop-down :: DHCP Relay*.

2. Click on the name (displays dialog).

3. Make changes as needed.

4. Click **Save**.

### Delete DHCP Relay

1. Go to *Network :: DHCP drop-down :: DHCP Relay*.

2. Select checkbox of Index to delete.

3. Click **Delete**.

## VPN drop-down > SSL VPN tab

**NOTE:** Access on VPN tab drop-down.

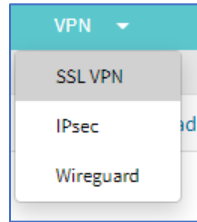

Nodegrid supports a wide variety of SSL configuration options. The System can act as either SSL client or SSL server, as needed by the customer configuration and security requirements.

### Client sub-tab

The VPN client configuration settings are generally used for failover scenarios. This is when a main secure connection fails over to a less secure connection type. The VPN tunnel is used to secure traffic. When the Nodegrid device is configured as an VPN client, it is bound to a network interface (optional) and the VPN tunnel is automatically established when the bounded interface starts. Multiple client configurations can be added that support different connection and interface details.

**NOTE:** Depending on the configuration, multiple files are required and must be available in the /etc/openvpn/CA folder.

Settings						
VPN						
Client						
Network :: SSL VPN :: Client						
<input type="button" value="Add"/> <input type="button" value="Delete"/> <input type="button" value="Start VPN"/> <input type="button" value="Stop VPN"/> <input type="button" value="Import OVPN"/>						
<input type="checkbox"/>	Name	Connection	Status	VPN Gateway	IPv4 Tunnel Net	IPv6 Tunnel Net
<input checked="" type="checkbox"/>	test	NONE	Unknown	121.0.0.1:1194:udp		

### Add Client

#### WebUI Procedure

1. Go to *Network :: VPN drop-down :: SSL VPN :: Client*.
2. Click **Add** (displays dialog).

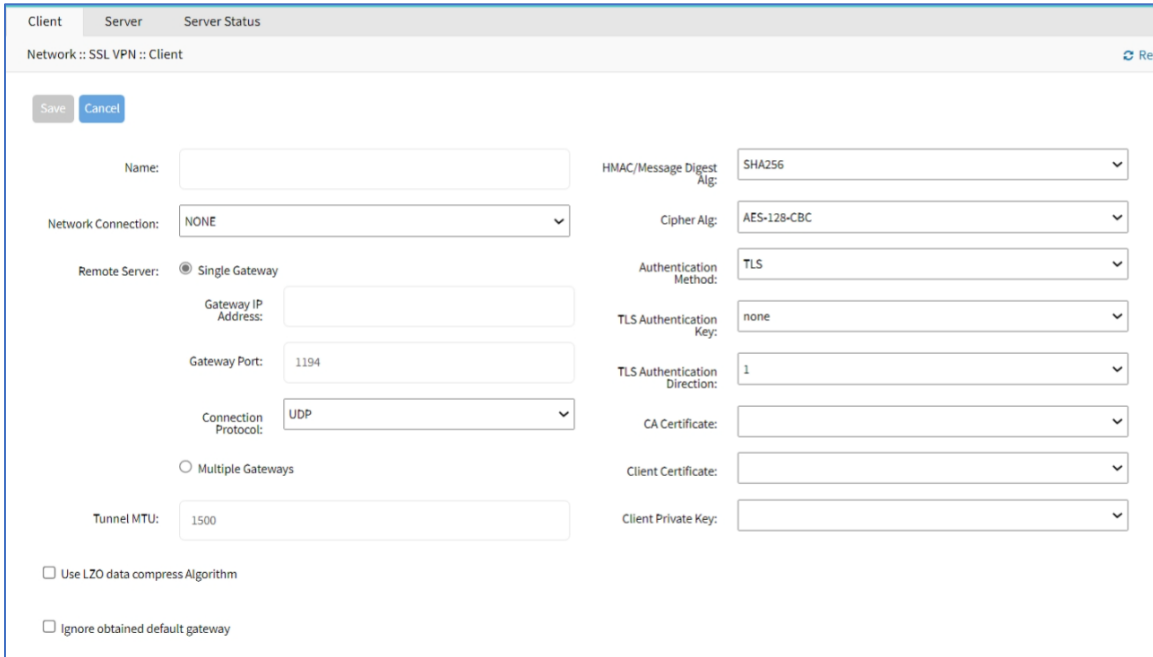

3. Enter **Name**.
4. On **Network Connection** drop-down, select one (**None, ETH0, ETH1, hotspot**).
5. In *Remote Server* menu, select:  
**Single Gateway** radio button:  
 Enter **Gateway IP Address**.  
 Enter **Gateway Port** (default: 1194).  
 On **Connection Protocol** drop-down, select one (**UDP, TCP**).

**Multiple Gateway** radio button:

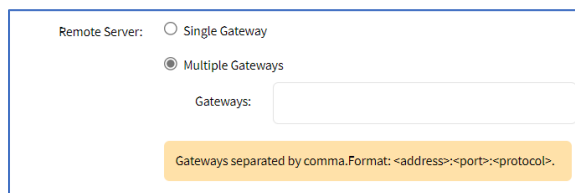

Enter **Gateways** (comma separated).

6. Enter **Tunnel MTU** (MTU size for the tunnel interface. Default: 1500).
7. Select **Use LZO data compress Algorithm** checkbox.
8. Select **Ignore obtained default gateway** checkbox.
9. On **HMAC/Message Digest Alg** drop-down, select one.
10. On **Cipher Alg** drop-down, select one.
11. On *Authentication Method* drop-down, select one.

On **TLS** selection:

For **TLS Authentication Key** drop-down, select one.

For **TLS Authentication Direction** drop-down, select one.

For **CA Certificate** drop-down, select one.

For **Client Certificate** drop-down, select one.

For **Client Private Key** drop-down, select one.

On **Static Key** selection:

For **Secret** drop-down, select one.

Enter **Local Endpoint (Local IP)**.

Enter **Remote Endpoint (Remote IP)**.

On **Password** selection:

Enter **Username**.

Enter **Password**.

For **CA Certificate** drop-down, select one.

On **Password plus TLS** selection:

Enter **Username**.

Enter **Password**.

For **TLS Authentication Key** drop-down, select one.

For **TLS Authentication Direction** drop-down, select one.

For **CA Certificate** drop-down, select one.

For **Client Certificate** drop-down, select one.

For **Client Private Key** drop-down, select one.

12. Click **Save**.

## Edit Client

### WebUI Procedure

1. Go to *Network :: VPN drop-down :: SSL VPN :: Client*.
2. On *Subnet/Netmask* column, click a name.
3. Make changes, as needed.
4. Click **Save**.

## Delete Client

### WebUI Procedure

1. Go to *Network :: VPN drop-down :: SSL VPN :: Client*.
2. Select checkbox to be deleted.
3. Click **Delete**.

## Start Client VPN

### WebUI Procedure

1. Go to *Network :: VPN drop-down :: SSL VPN :: Client*.
2. Select checkbox next to client to be started.
3. Click **Start VPN**.

## Stop Client VPN

### WebUI Procedure

1. Go to *Network :: VPN drop-down :: SSL VPN :: Client*.
2. Select checkbox next to client to be stopped.
3. Click **Stop VPN**.

## Import OVPN

### WebUI Procedure

1. Go to *Network :: VPN drop-down :: SSL VPN :: Client*.
2. Click **Import OVPN** (displays dialog).

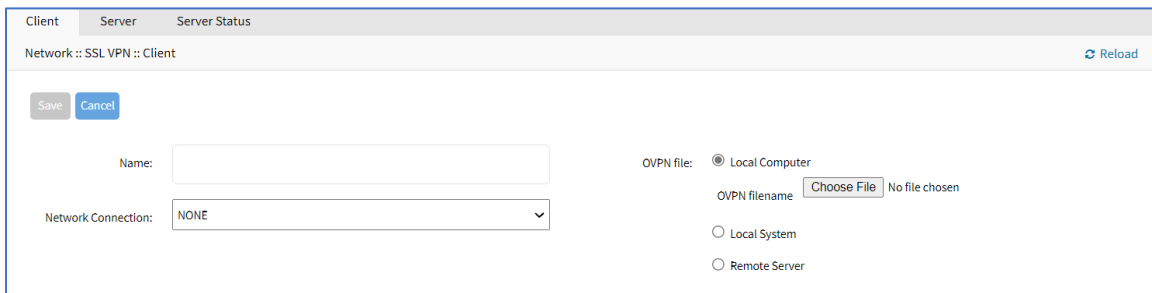

The screenshot shows a web interface dialog for importing an OVPN file. At the top, there are tabs for 'Client', 'Server', and 'Server Status', with 'Client' selected. Below the tabs, the breadcrumb path is 'Network :: SSL VPN :: Client' and there is a 'Reload' button. The dialog contains the following fields and options:

- 'Save' and 'Cancel' buttons at the top left.
- 'Name:' text label followed by an empty text input field.
- 'Network Connection:' text label followed by a dropdown menu currently showing 'NONE'.
- 'OVPN file:' text label followed by three radio button options: 'Local Computer' (which is selected), 'Local System', and 'Remote Server'.
- Below the radio buttons, there is an 'OVPN filename' text label followed by a 'Choose File' button and the text 'No file chosen'.

3. Enter **Name**.
4. On **Network Connection** drop-down, select one (**NONE, ETH0, ETH1, hotspot**).
5. In *OVPN File* menu:
  - Select **Local Computer** radio button:
    - Click **Choose File**. Locate and select the file.
  - Select **Local System** radio button:

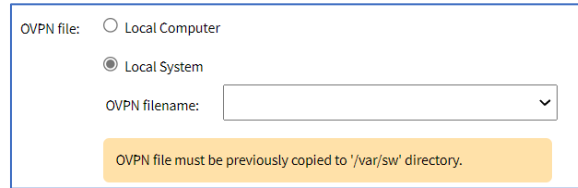

On **OVPN filename** drop-down, select one.

Select **Remote Server** radio button:

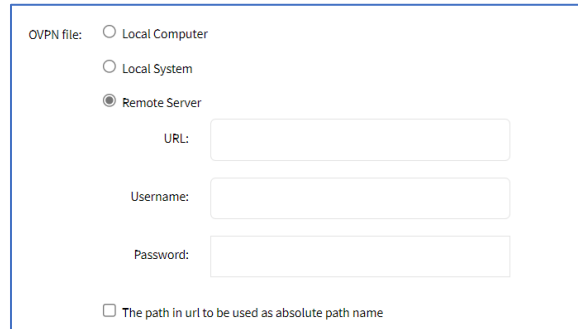

Enter **URL**.

Enter **Username**.

Enter **Password**.

(optional) Select **The path in url to be used as absolute path name** checkbox.

6. Click **Save**.

### **Server sub-tab**

Nodegrid can be configured as a VPN server. By default, this is disabled. Depending on the configuration, multiple files are required and must be available in the /etc/openvpn/CA folder.



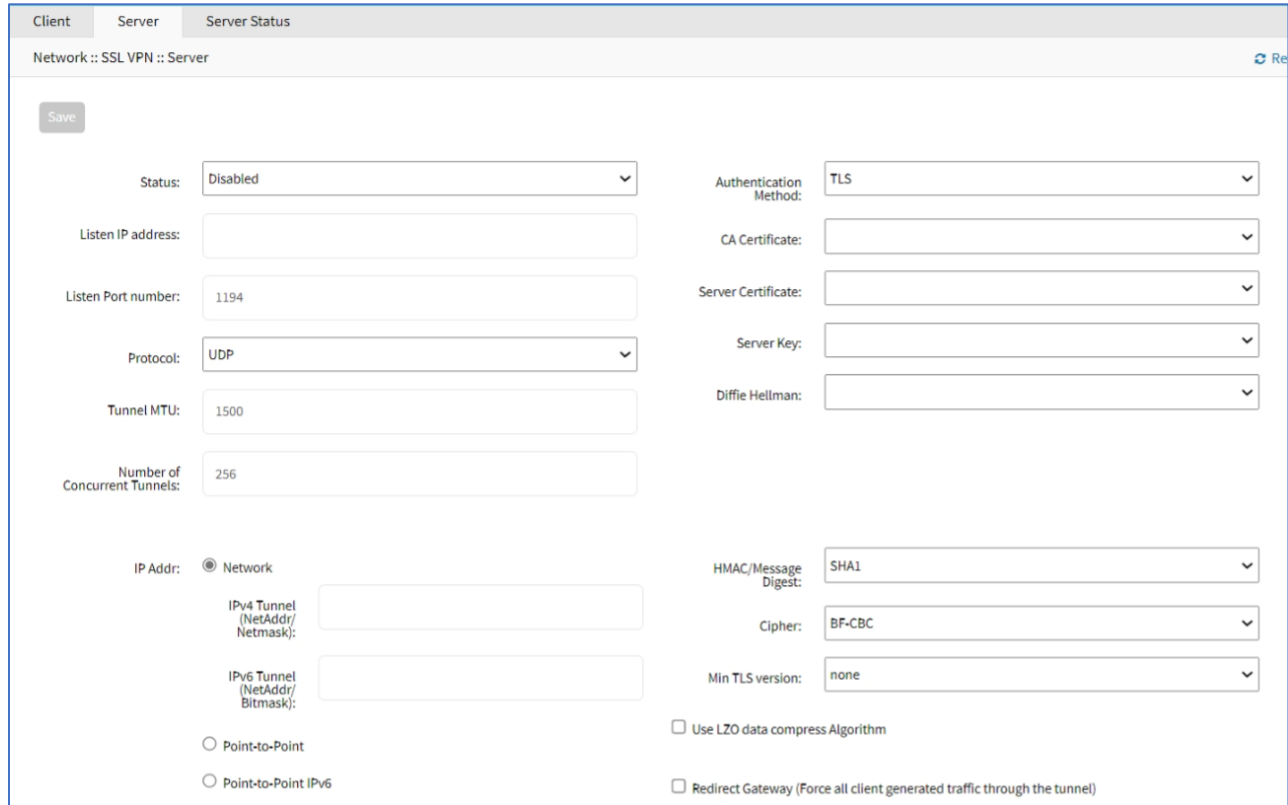

The screenshot shows the 'Server Status' configuration page for an SSL VPN server. The 'Status' is set to 'Disabled'. The 'Listen IP address' is empty, and the 'Listen Port number' is 1194. The 'Protocol' is set to 'UDP', and the 'Tunnel MTU' is 1500. The 'Number of Concurrent Tunnels' is 256. Under 'IP Addr:', the 'Network' radio button is selected. There are input fields for 'IPv4 Tunnel (NetAddr/Netmask):' and 'IPv6 Tunnel (NetAddr/Bitmask):'. The 'Authentication Method' is set to 'TLS'. Other settings include 'CA Certificate', 'Server Certificate', 'Server Key', and 'Diffie Hellman', all with empty input fields. The 'HMAC/Message Digest' is set to 'SHA1', and the 'Cipher' is 'BF-CBC'. The 'Min TLS version' is set to 'none'. There are two checkboxes at the bottom: 'Use LZ0 data compress Algorithm' and 'Redirect Gateway (Force all client generated traffic through the tunnel)', both of which are unchecked.

## Configure SSL VPN Server Details

### WebUI Procedure

1. Go to *Network :: VPN drop-down :: VPN :: Server*.
2. On **Status** drop-down, select one (after configuration as a VPN server, must be enabled)
  - Enabled**
  - Disabled** (default)
3. Enter **Listen IP address** (if defined, server only responds to client requests coming in this interface)  
Enter **Listen Port number** (listening port for incoming connections - default: 1194).
4. On **Protocol** drop-down, select one (**UDP, TCP, UDP IPv6, TCP IPv6**).  
Enter **Tunnel MTU** (default: 1500).  
Enter **Number of Concurrent Tunnels** (default: 256).
5. *Authentication Method* menu – enter details (different fields are displayed according to selection)
  - On **TLS** selection:
    - For **CA Certificate** drop-down, select one.
    - For **Server Certificate** drop-down, select one.
    - For **Server Key** drop-down, select one.

For **Diffie Hellman** drop-down, select one.

On **Static Key** selection:

For **Secret** drop-down, select one.

For **Diffie Hellman** drop-down, select one.

On **Password** selection:

For **CA Certificate** drop-down, select one.

For **Server Certificate** drop-down, select one.

For **Server Key** drop-down, select one.

For **Diffie Hellman** drop-down, select one.

On **Password plus TLS** selection:

For **CA Certificate** drop-down, select one.

For **Server Certificate** drop-down, select one.

For **Server Key** drop-down, select one.

For **Diffie Hellman** drop-down, select one.

6. *IP Address* menu (display changes based on selection) IP address settings for the tunnel:

Select **Network** radio button:

Enter **IPv4 Tunnel** (NetAddr/Netmask).

Enter **IPv6 Tunnel** (NetAddr/Netmask):.

Select **Point to Point** radio button:

Enter **Local Endpoint** (Local IP).

Enter **Remote Endpoint** (Remote IP).

Select **Point To Point IPv6** radio button:

Enter **Local Endpoint** (Local IPv6).

Enter **Remote Endpoint** (Remote IPv6).

On **HMAC/Message Digest** drop-down (select HMAC connection algorithm).

On **Cipher** drop-down (select connection cipher algorithm).

On **Min TLS version** drop-down, select one (**None, TLS 1.0, TLS 1.1, TLS 1.2, TLS 1.3**)..

Select **Use LZO data compress Algorithm** checkbox (all tunnel traffic is compressed).

Select **Redirect Gateway (Force all client generated traffic through the tunnel)** checkbox (all traffic from a client is forced through the tunnel).

7. Click **Save**.

## Edit VPN Server Details

### WebUI Procedure

1. Go to *Network :: VPN drop-down :: VPN :: Server*.
2. Make modifications, as needed.
3. Click **Save**.

### Server Status sub-tab

When the device is configured and started as a VPN server , this page provides an overview of the general server status and connected clients.

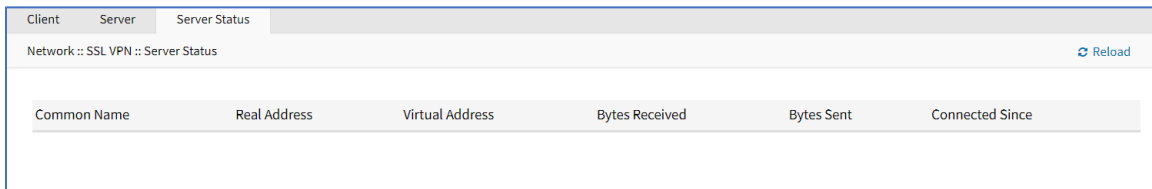

Client	Server	Server Status			
Network :: SSL VPN :: Server Status <span style="float: right;">Reload</span>					
Common Name	Real Address	Virtual Address	Bytes Received	Bytes Sent	Connected Since

## VPN drop-down > IPsec tab

**NOTE:** Access on VPN tab drop-down.

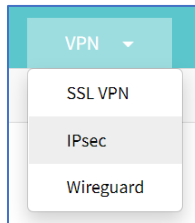

The Nodegrid solution supports the IPsec tunnel configuration with a variety of options for host-to-host, host-to-site, site-to-site and road warrior settings. The Nodegrid node is directly exposed to the Internet. It is strongly recommended the device be secured. Built-in features include:

- Firewall configuration
- Enable Fail-2-Ban
- Change all default passwords with strong passwords
- Disable services not required

## Overview

### Authentication Methods

Multiple authentication methods are available. Some are simple (Pre-Shared keys and RSA keys) but with limited flexibility. Others require more initial configuration and setup which offers flexibility and consistency.

### Pre-shared Keys

Pre-shared Keys provide the simplest and least secure method to secure an IPsec connection. This is a combination of characters that represent a secret. Both nodes must share the same secret. Nodegrid supports pre-shared keys with a minimum length of 32 characters. The maximum length is much higher. Due to compatibility reasons with other vendors, Nodegrid uses a 64-bit length for the examples. The longer the pre-shared key is, the more secure it is.

### RSA Keys

RSA Keys or Raw RSA keys are commonly used for static configurations between single or a few hosts. The nodes are manually configured with each other's RSA keys.

### X.509 Certificates

Typically, X.509 Certificate authentications are used for larger deployments with a few to many nodes. The RSA keys of the individual nodes are signed by a central Certificate Authority (CA). The Certificate Authority maintains the trust relationship between the nodes. As needed, specific nodes can include revocation of trust. Nodegrid supports both public and private CA's. As needed, the Nodegrid Platform can host and manage its own Certificate Authority for IPsec communication.

## Connection Scenarios

IPsec supports many connection scenarios, from the basic one-to-one nodes and the more complex one-to-many nodes. Communication can be limited to the directly involved nodes. If needed, communication can be expanded to the networks access table behind the nodes. Examples are provided for some of the most common scenarios.

### Host-to-Host

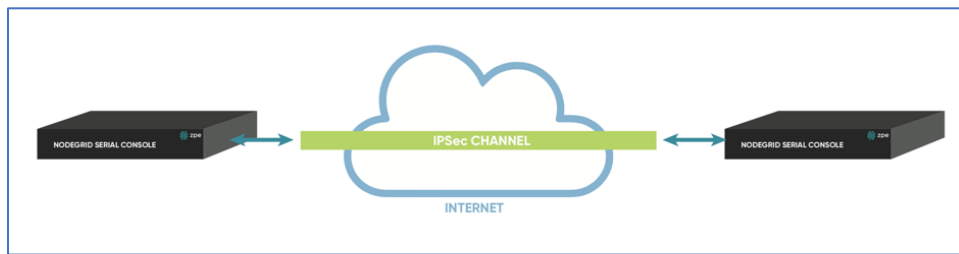

Host-to-Host communication is two nodes directly connected with a VPN tunnel. The communication is limited to direct communication between them. None of the packages are routed or forwarded. This is a point-to-point communication tunnel between two nodes.

### Host-to-Site

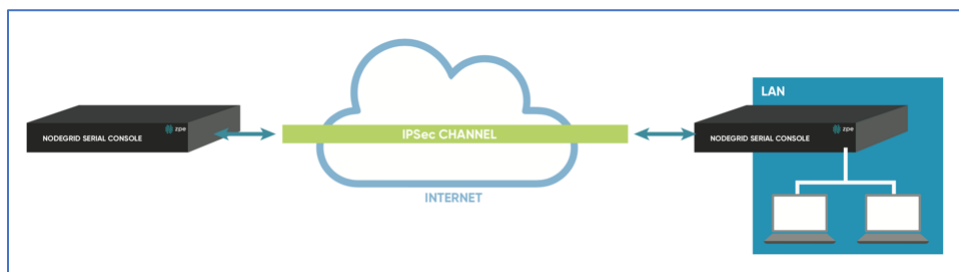

With host-to-Site, one node establishes a VPN tunnel to a second node. Communication is limited on one site to the specific node; and on the other side, limited to all devices in a range of subnet accessible by the second node.

### Site-to-Site

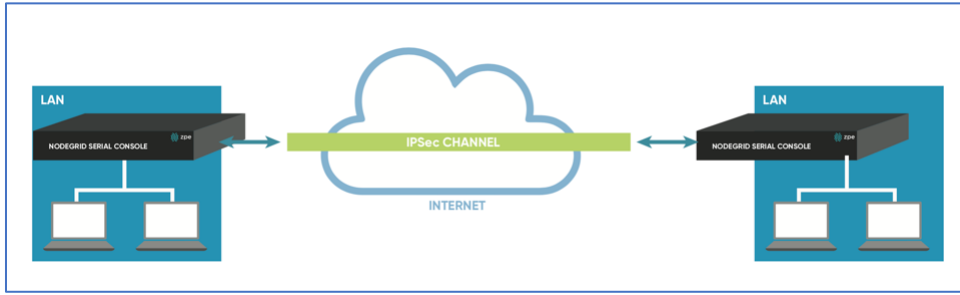

In site-to-site, the tunnel is established between two nodes. Communication can specify the subnet on both sides. This allows communication between devices on either side of the connection.

### Host-to-Multi-Site

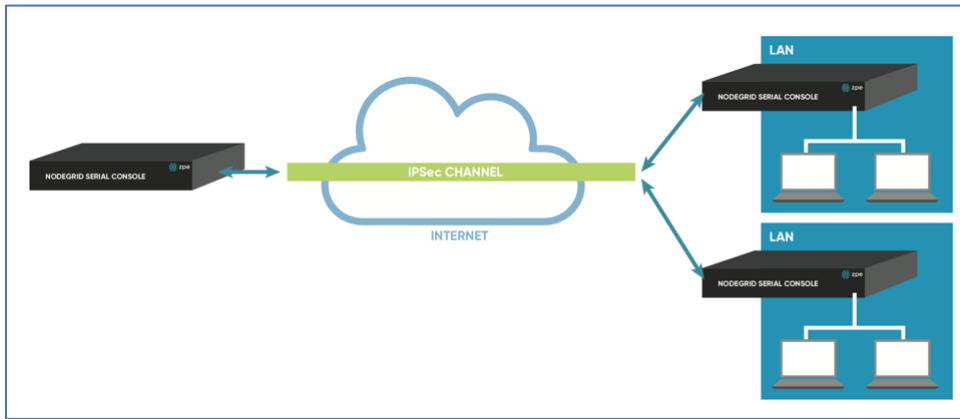

Host-to-multi-site communication is created with individual VPN connections. This is done between hosts or with specific multi-site configurations (which greatly improves scalability). Multiple nodes can connect to the same node. A typical use would be remote offices with a VPN connection to the main office. This would limit communications to the one node and devices on specified subnets in the remote locations.

### Site-to-Multi-Site

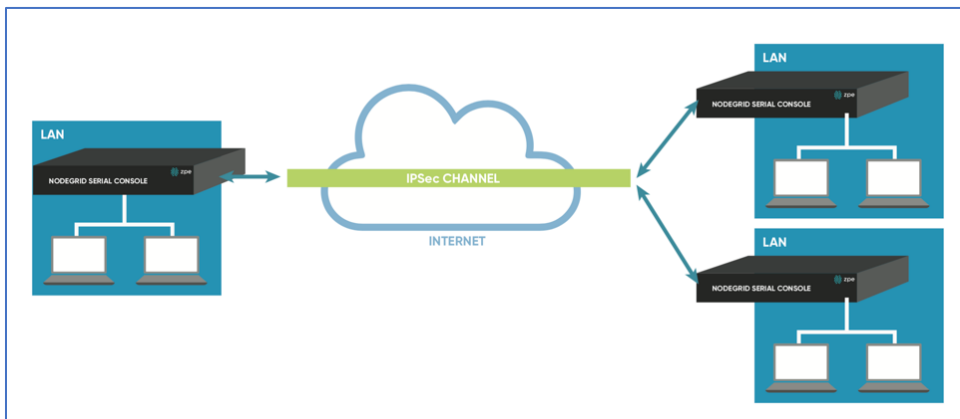

Site-to-multi-site is most common for enterprise VPN setups. Similar to host-to-multi-site, communication is allowed to the specific subnet on either side. The West node would have access

to all specified subnet on any of the sites. The remote sites only can access the subnet exposed by the West node.

## Keys and Certificates

### Keys and Certificates

	Host to Host	Host to Site	Site to Site	Host to Multi-Site	Site to Multi-Host
Pre-shared Keys	Possible	Possible	Possible	Possible	Possible
RSA Key	Recommended	Recommended	Recommended	Possible	Possible
X.509 Certificates	Recommended	Recommended	Recommended	Recommended	Recommended

## IPsec Configuration Process

These are the general configuration steps to configure the desired connection.

1. To prepare the Nodegrid, see [How to Prepare a Nodegrid Node for IPsec](#)
2. Ensure that one of the authentication methods is prepared:

[How to create Pre-shared Keys for IPsec](#)

[How to create RSA Keys for IPsec](#)

[How to Create Certificates for IPsec](#)

**NOTE:** For Production environments, it is recommended to use RSA Keys or Certificate Authentication. For a test environment, Pre-Shared Keys are easy to set up.

3. Create an IPsec configuration file. Configuration examples can be found here:

### Pre-Shared Keys

[How to Configure IPsec Host to Host Tunnel with Pre-Shared Key](#)

[How to configure IPsec Host to Site tunnel with Pre-Shared Key](#)

[How to Configure IPsec Site to Site Tunnel with Pre-Shared Key](#)

### RSA Keys

[How to Configure IPsec Host to Host Tunnel with RSA Keys](#)

[How to Configure IPsec Host to Site tunnel with RSA Keys](#)

[How to Configure IPsec Site to Site Tunnel with RSA Keys](#)

### Certificates

[How to Configure IPsec Host to Host Tunnel with Certificate](#)

[How to Configure IPsec Host to Site Tunnel with Certificate](#)

[How to Configure IPsec Site to Site Tunnel with Certificate](#)

4. As required, distribute and exchange configuration files and keys to all nodes
5. Test the connection.

For more detailed guides on how to use IPsec with the Nodegrid Platform, visit the [Knowledge Base](#).

**Tunnel sub-tab**

The main table displays available tunnels.

Tunnel		IKE Profile	Global			
Network :: IPsec :: Tunnel <span style="float: right;">↻ Reload</span>						
<input type="button" value="Add"/> <input type="button" value="Delete"/> <input type="button" value="Start Tunnel"/> <input type="button" value="Stop Tunnel"/>						
<input type="checkbox"/>	Name	Authentication Method	Left ID	Right ID	IKE Profile	Status
<input type="checkbox"/>	test	Pre-Shared Key			nodegrid	Down

**Add a New Tunnel**

**WebUI Procedure**

1. Go to *Network :: VPN drop-down :: IPsec :: Tunnel*.
2. Click **Add** (displays dialog).

Tunnel IKE Profile Global

Network :: IPsec :: Tunnel :: test ↻ Reload

Name:

Initiate Tunnel:

IKE Profile:

Authentication Method:  Pre-Shared Key

Secret:

RSA Key

**Local**

Left ID:

Left Address:

Left Source IP Address:

Left Subnet:

**Remote**

Right ID:

Right Address:

Right Source IP Address:

Right Subnet:

Monitoring  Enable Monitoring

Virtual Tunnel Interface  Enable Virtual Tunnel Interface

3. Enter **Name**.
4. On **Initiate Tunnel** drop-down, select one (**Start, Ignore, On-Demand**),
5. On **IKE Profile** drop-down, select one (**Cisco\_ASA, PaloAlto, nodegrid**).

6. (optional) On **Custom Up/Down Script** drop-down, select one (this customized script can set configuration changes and activities, when the tunnel is up or down).

7. In *Authentication Method* menu, select one:

Select **Pre-Shared Key** radio button (expands dialog).

Enter **Secret**.

Select **RSA Key** radio button (expands dialog):

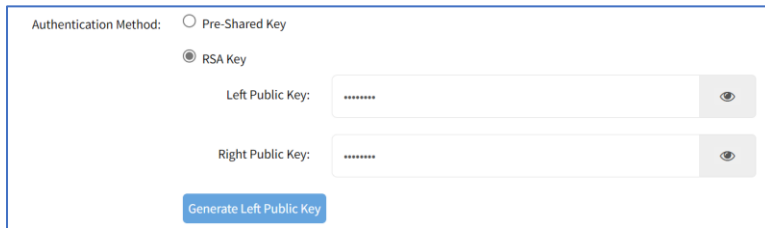

Enter **Left Public Key**.

Enter **Right Public Key**.

Click **Generate Left Public Key**.

8. In *Local* menu:

Enter **Left ID**.

On **Left Address** drop-down, select one (selection depends on the system configuration).

Enter **Left Source IP Address**.

Enter **Left Subnet**.

9. In *Remote* menu:

Enter **Right ID**.

Enter **Right Address**.

Enter **Right Source IP Address**.

Enter **Right Subnet**.

10. (optional) In *Monitoring* menu, select **Enable Monitoring** checkbox (expands dialog).



### Monitoring

---

**Enable Monitoring**

Source IP Address:

Destination IP Address:

Number of Retries:

Interval (sec):

Action:

Enter **Source IP Address** (ping from).

Enter **Destination IP Address** (ping to).

Enter **Number of Retries** (pings before triggering Action).

Enter **Interval (seconds)** (time between retries).

On **Action** drop-down, select one (if tunnel does not respond):

**Restart IPsec** (to resolve issues with key negotiation).

**Restart Tunnel** (to resolve issues with key negotiation).

**Failover** (fails over to another IPsec tunnel).

**NOTE:** The number of retries and interval should be greater than that of the dead peer detection configuration within the IKE profile.

11. (optional) In *Virtual Tunnel Interface* menu, select **Enable Virtual Tunnel Interface** checkbox (expands dialog).

### Virtual Tunnel Interface

---

**Enable Virtual Tunnel Interface**

Mark:

Address:

Interface:

**Automatically create VTI routes**

**Share VTI with other connections**

Enter **Mark**.

Enter **Address**.

Enter **Interface**.

Select **Automatically create VTI routes**.

Select **Share VTI with other connections**.

12. Click **Save**.

## Edit a Tunnel

### WebUI Procedure

1. Go to *Network :: VPN drop-down :: IPsec :: Tunnel*.
2. In the *Name* column, click a name (displays dialog).
3. Make changes, as needed.
4. Click **Save**.

## Delete a Tunnel

### WebUI Procedure

1. Go to *Network :: VPN drop-down :: IPsec :: Tunnel*.
2. In the table, select checkbox of tunnel to delete.
3. Click **Delete**.

## Start a Tunnel

### WebUI Procedure

1. Go to *Network :: VPN drop-down :: IPsec :: Tunnel*.
2. In the table, select checkbox of tunnel to start.
3. Click **Start Tunnel**.

## Stop a Tunnel

### WebUI Procedure

1. Go to *Network :: VPN drop-down :: IPsec :: Tunnel*.
2. In the table, select checkbox of tunnel to stop.
3. Click **Stop Tunnel**.

## IKE Profile sub-tab

IKE Profiles are managed on this page.

Tunnel IKE Profile Global				
Network :: IPsec :: IKE Profile <span style="float: right;">Reload</span>				
Add Delete				
<input type="checkbox"/>	Profile Name	IKE Version	Mode	Authentication Protocol
<input type="checkbox"/>	Cisco_ASA	IKEv2	Not Applicable	ESP
<input type="checkbox"/>	PaloAlto	IKEv1	Main	ESP
<input type="checkbox"/>	nodegrid	IKEv2	Not Applicable	ESP

## Add a New Profile

### WebUI Procedure

1. Go to *Network :: VPN drop-down :: IPsec :: IKE Profile*.
2. Click **Add** (displays dialog).

3. Enter **Profile Name**.
4. On **IKE Version** drop-down, select one (**IKEv1**, **IKEv2**) (modifies *Phase 1* selection).

(IKEv1 selection)

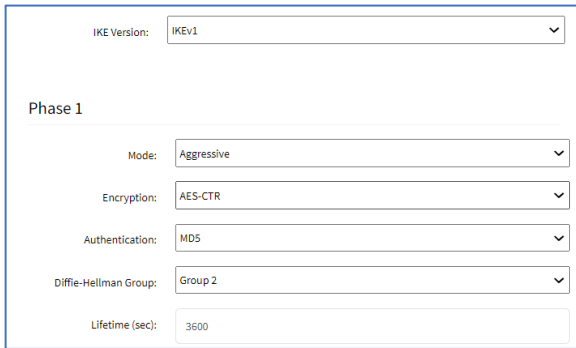

The screenshot shows the IKEv1 configuration interface. At the top, 'IKE Version' is set to 'IKEv1'. Under the 'Phase 1' section, the following settings are visible: 'Mode' is set to 'Aggressive', 'Encryption' is 'AES-CTR', 'Authentication' is 'MD5', 'Diffie-Hellman Group' is 'Group 2', and 'Lifetime (sec)' is '3600'.

(IKEv2 selection)

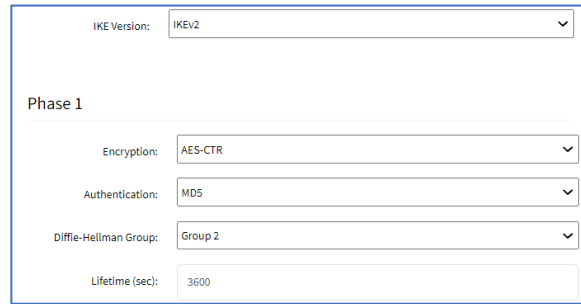

The screenshot shows the IKEv2 configuration interface. At the top, 'IKE Version' is set to 'IKEv2'. Under the 'Phase 1' section, the following settings are visible: 'Encryption' is 'AES-CTR', 'Authentication' is 'MD5', 'Diffie-Hellman Group' is 'Group 2', and 'Lifetime (sec)' is '3600'.

(if IKEv1) On **Mode** drop-down, select one (**Aggressive, Main**).

On **Encryption** drop-down, select one (**3DES, AES, AES192, AES256, AES-CBC, AES-CBC192, AES-CBC256, AES-CTR, AES-CTR192, AES-CTR256, AES-GCM, AES-GCM192, AES-GCM256**).

On **Authentication** drop-down, select one (**SHA1, SHA256, SHA384, SHA512, MD5**).

On **Diffie-Hellman Group** drop-down, select one (**Group 2, 5, 14, 15, 16, 17, 18, 19, 20, 21, 31**).

Enter **Lifetime (sec)** value.

- In **Phase 2** menu, **Authentication Protocol** drop-down, select one (**ESP, AH**).

(ESP selection)



The screenshot shows the Phase 2 configuration for ESP selection. 'Authentication Protocol' is set to 'ESP'. There are two panels for 'Encryption' and 'Authentication'. The left panel of 'Encryption' lists: 3DES, AES, AES192, AES256, AES-CBC, AES-CBC192, AES-CBC256, AES-CTR. The right panel is empty. Below, the 'Authentication' left panel lists: SHA1, SHA256, SHA384, SHA512, MD5, Null. The right panel is empty. At the bottom, 'PFS Group' is 'None' and 'Lifetime (sec)' is '28800'.

(AH selection)

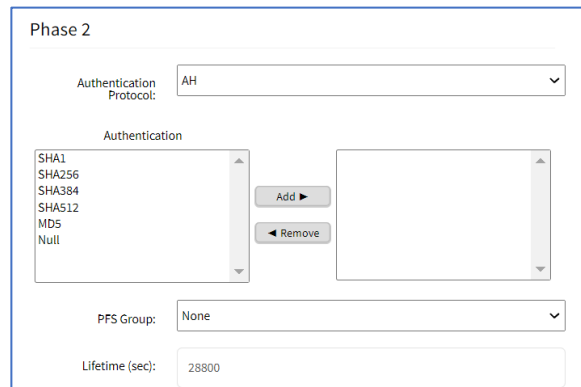

The screenshot shows the Phase 2 configuration for AH selection. 'Authentication Protocol' is set to 'AH'. There are two panels for 'Authentication'. The left panel lists: SHA1, SHA256, SHA384, SHA512, MD5, Null. The right panel is empty. At the bottom, 'PFS Group' is 'None' and 'Lifetime (sec)' is '28800'.

(ESP selection only) On **Encryption**, select from left-side panel, click **Add ►** to move to right-side panel.

To remove from right-side panel, select, and click **◀ Remove**.

On **Authentication**, select from left-side panel, click **Add ►** to move to right-side panel.

To remove from right-side panel, select, and click **◀ Remove**.

- In **Advanced Settings** menu, dialog expands if **Enable Dead Peer Detection** checkbox is selected.

(unselected)



(selected)

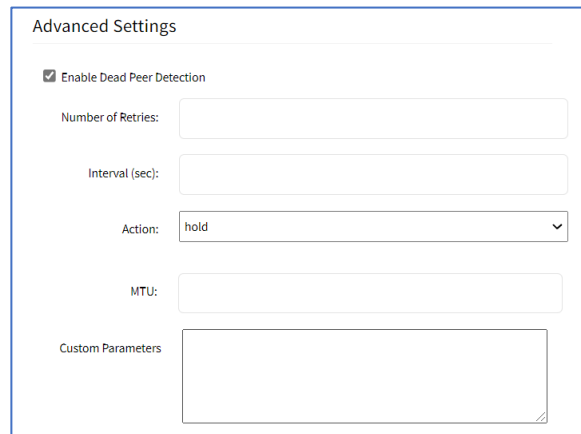

(if selected) Enter value on **Enter number of retries**.

Enter **Interval (sec)**.

On **Action** drop-down, select one (**hold, clear, restart**).

Enter **MTU**.

Enter **Custom Parameters** (comma separated).

7. Click **Save**.

## Edit a Profile

### WebUI Procedure

1. Go to *Network :: VPN drop-down :: IPsec :: IKE Profile*.
2. Locate and click on the **Profile Name**.
3. Modify details, as needed.
4. Click **Save**.

## Delete a Profile

### WebUI Procedure

1. Go to *Network :: VPN drop-down :: IPsec :: IKE Profile*.
2. Click the checkbox next to the profile to delete.
3. Click **Delete**.

## Global sub-tab

### Edit Global Options

#### WebUI Procedure

1. Go to *Network :: VPN drop-down :: IPsec :: Global*.

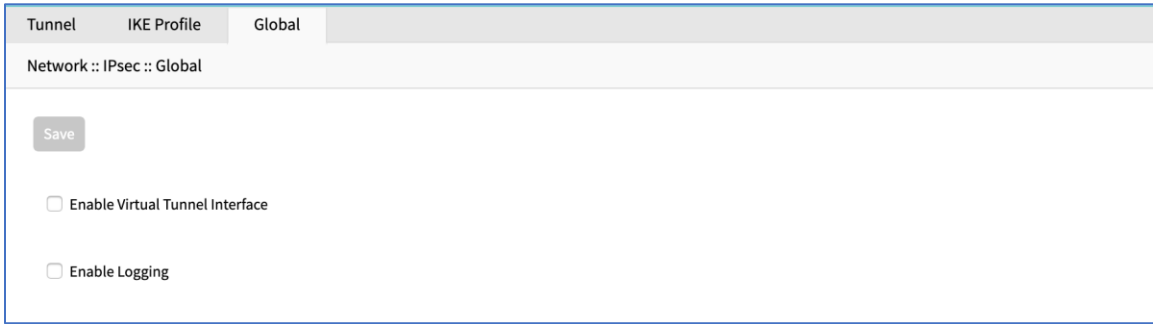

2. Select/unselect **Enable Virtual Tunnel Interface** checkbox.
3. Select/unselect **Enable Logging** checkbox.
4. Click **Save**.

## VPN drop-down > Wireguard tab

**NOTE:** Access on VPN tab drop-down.

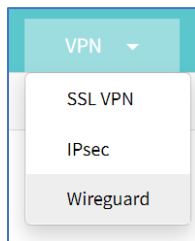

Wireguard is a simple to use VPN protocol. Wireguard establishes a site to site tunnel. Wireguard is supported in the admin CLI, GUI, and API on Nodegrid devices v5.2+.

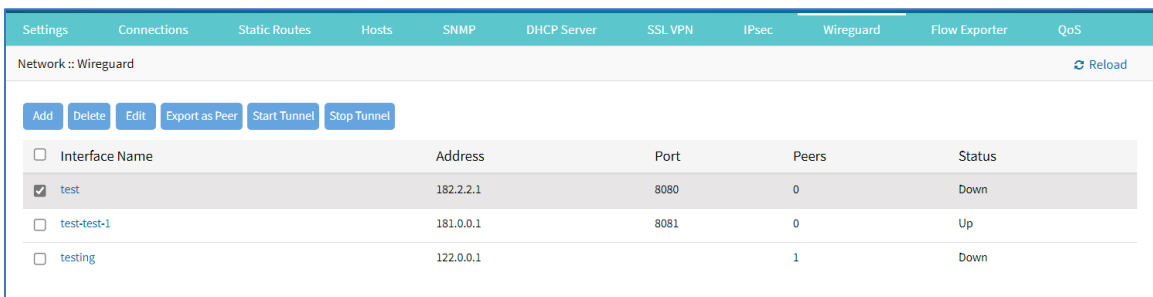

### Advantages

- Uses a current elliptic curve algorithm for the encryption
- Uses RSA keys and optional PSK's for authentication
- Roaming of End Points is an integrated part of the solution
- Good Client support, with native support for Windows, MacOS, Linux, iOS and Android
- Native support for tunnel interfaces to allow for Multicast traffic
- Support for IPv6 and IPv4 over the same interface

- Part of the Linux kernel ensures long term support

## Manage Wireguard Configurations

### Step 1 – Add a Wireguard Configuration

#### WebUI Procedure

1. Go to *Network :: VPN drop-down :: Wireguard*.
2. Click **Add** (opens dialog).

Enter **Interface Name**.

On **Interface Type** drop-down, select one (display modifies, based on selection).

**Server** interface type:

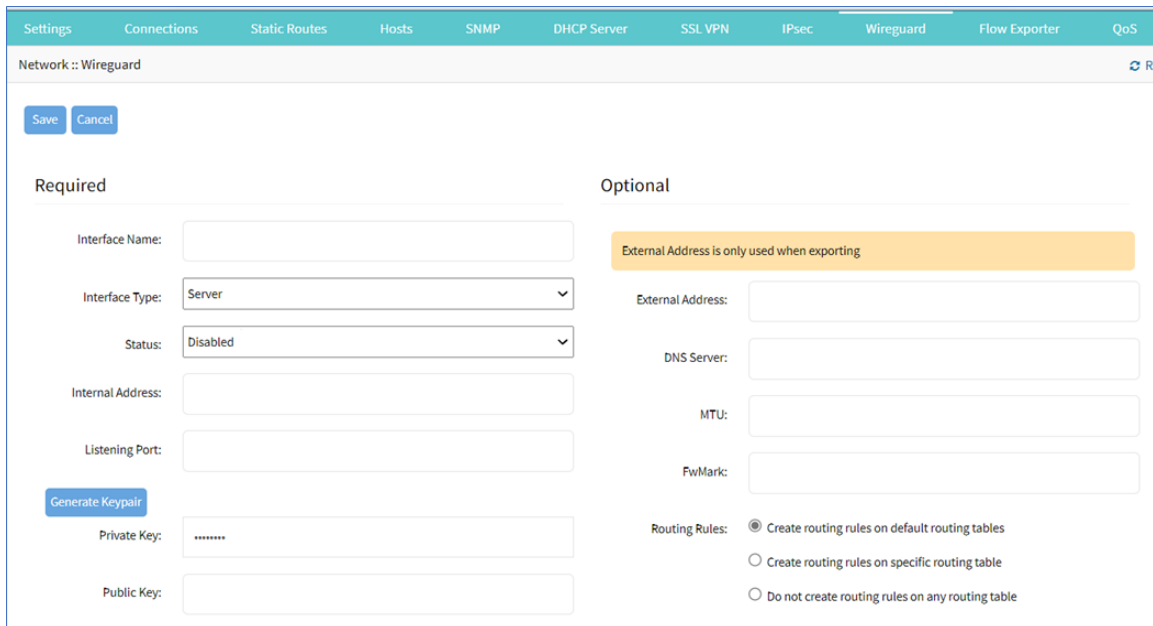

On **Status** drop-down, select one (**Enabled, Disabled**).

Enter **Internal Address**.

Enter **Listening Port**.

Click **Generate Keypair**.

In *Optional* menu, enter **External Address**.

**Client interface type:**

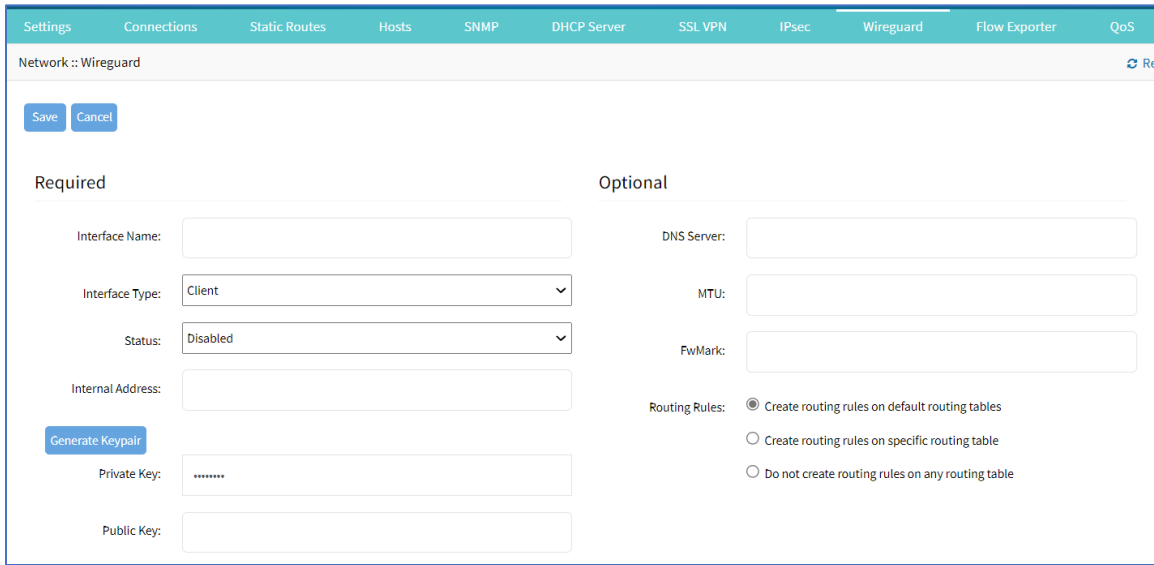

On **Status** drop-down, select one (**Enabled, Disabled**).

Enter **Internal Address**.

Click **Generate Keypair**.

**Mesh interface type:**

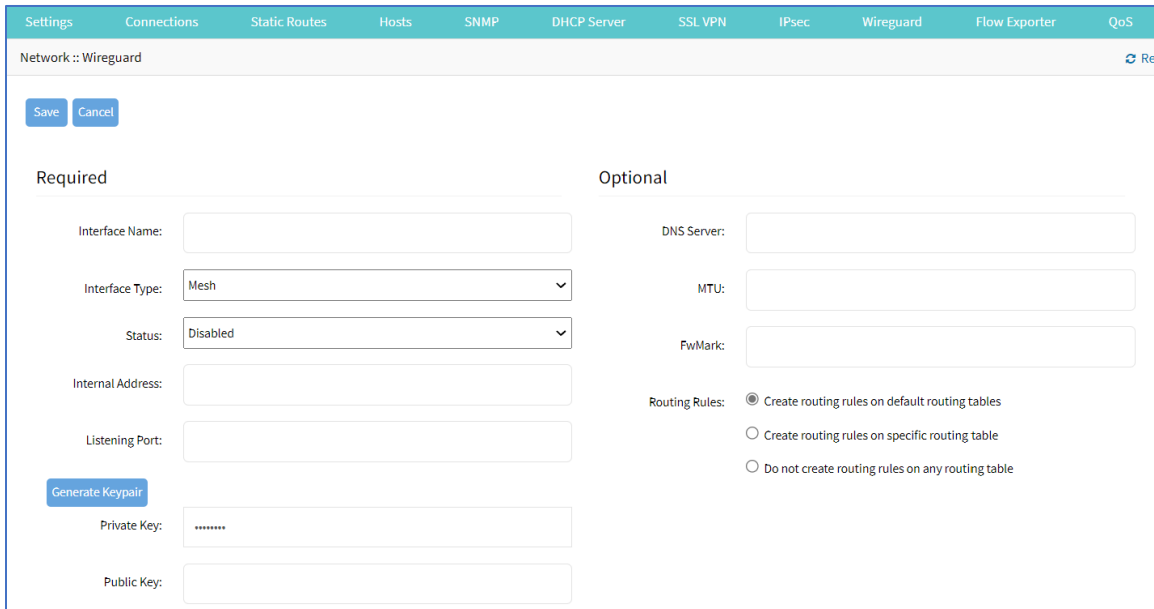

On **Status** drop-down, select one (**Enabled, Disabled**).

Enter **Internal Address**.

Enter **Listening Port**.

Click **Generate Keypair**.



3. In *Optional* menu:  
 Enter **DNS Server**.  
 Enter **MTU**.  
 Enter **FwMark**.
4. In *Routing Rules* menu, select one.  
**Create routing rules on default routing tables** radio button.  
**Create routing rules on specific routing table** radio button.  
**Do not create routing rules on any routing table** radio button.
5. Click **Save**.

## Step 2 – Configure the Peer.

1. On the table, click the **Name** of the new configuration (displays dialog).

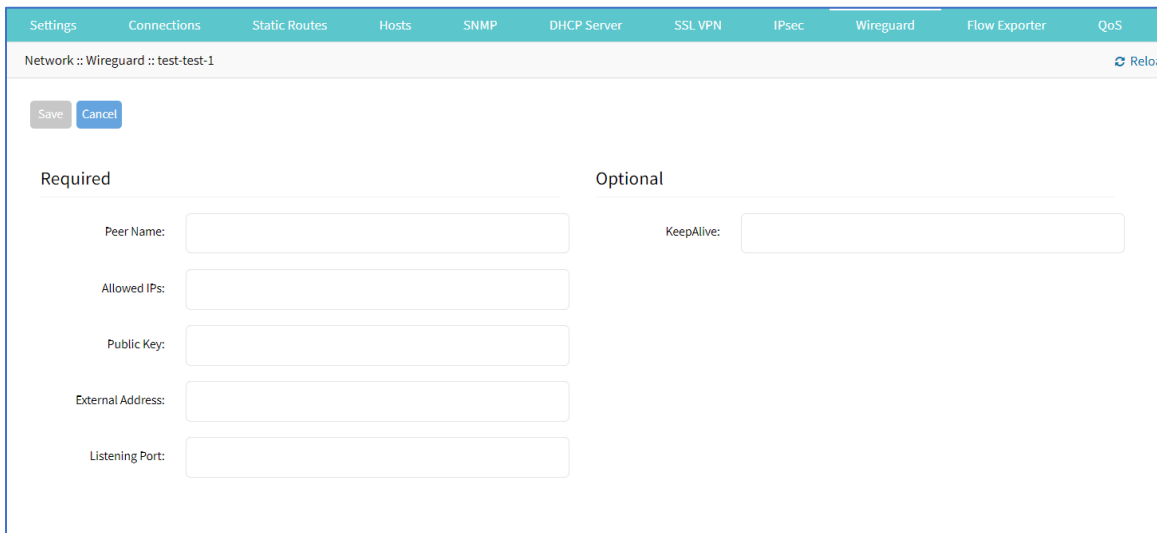

Settings Connections Static Routes Hosts SNMP DHCP Server SSL VPN IPsec Wireguard Flow Exporter QoS

Network :: Wireguard :: test-test-1 Relo

Save Cancel

Required

Peer Name:

Allowed IPs:

Public Key:

External Address:

Listening Port:

Optional

KeepAlive:

2. In the *Required* menu:  
 Enter **Peer Name**.  
 Enter **Allowed IPs** (comma-separated).  
 Enter **Public Key**.  
 Enter **External Address**.  
 Enter **Listening Port**.
3. In the *Optional* menu, enter **Keepalive** value.
4. Click **Save**.

### CLI Procedure

1. Add the Wireguard configuration details:

Configure these commands:

```
[admin@nodegrid /]# cd /settings/wireguard/
[admin@nodegrid {wireguard}]# set <to configure these parameters>
  dns_server=<value>
  interface_name=<value>
  listening_port=<value>
  public_key=<value>
  external_address=<value>
  interface_type=<value>
  mtu=<value>
  routing_rules=<value>
  fwmark=<value>
  internal_address=<value>
  private_key=<value>
  status=<value>
[admin@nodegrid {wireguard}]# commit
```

## 2. Configure peers:

```
[admin@nodegrid wireguard]# cd Interface_Name/
[admin@nodegrid Server_Interface]# cd peers/
[admin@nodegrid peers]# add
[admin@nodegrid {peers}]# set <to configure these parameters>
  allowed_ips=<value>
  keepalive=<value>
  peer_name=<value>
  external_address=<value>
  listening_port=<value>
  public_key=<value>
[admin@nodegrid {peers}]# commit
```

## Delete a Wireguard Configuration

### WebUI Procedure

1. Go to *Network :: VPN drop-down :: Wireguard*.
2. On the table, select checkbox of configuration to delete.
3. Click **Delete**.

## Edit a Wireguard Configuration

### WebUI Procedure

1. Go to *Network :: VPN drop-down :: Wireguard*.
2. On the table, select checkbox of configuration to edit.
3. Click **Edit** (displays dialog).
4. Make changes as needed.

5. Click **Save**.

## Export Peer

### WebUI Procedure

1. Go to *Network :: VPN drop-down :: Wireguard*.

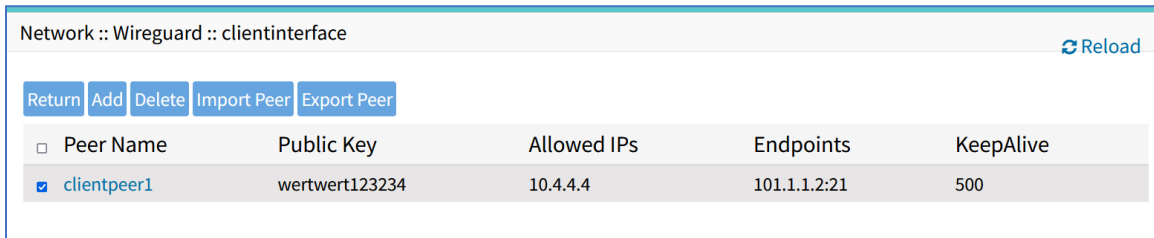

Network :: Wireguard :: clientinterface <span style="float: right;">Reload</span>					
<span>Return</span> <span>Add</span> <span>Delete</span> <span>Import Peer</span> <span>Export Peer</span>					
<input type="checkbox"/>	Peer Name	Public Key	Allowed IPs	Endpoints	KeepAlive
<input checked="" type="checkbox"/>	clientpeer1	wertwert123234	10.4.4.4	101.1.1.2:21	500

2. On the table, select checkbox of configuration to export.

3. Click **Export Peer**.

The file is downloaded to the local download location.

## Import Peer

### WebUI Procedure

1. Go to *Network :: VPN drop-down :: Wireguard*.

2. Click **Import Peer** (displays dialog).

3. Enter **Name**.

4. Select one:

**Local Computer** radio button (expands dialog):

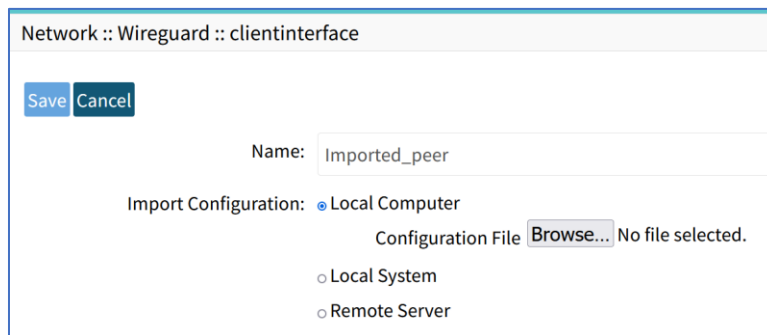

Network :: Wireguard :: clientinterface

Save Cancel

Name:

Import Configuration:  Local Computer

Configuration File  No file selected.

Local System

Remote Server

Enter **Name**.

Click **Browse** to locate and select the file.

**Local System** radio button (expands dialog):

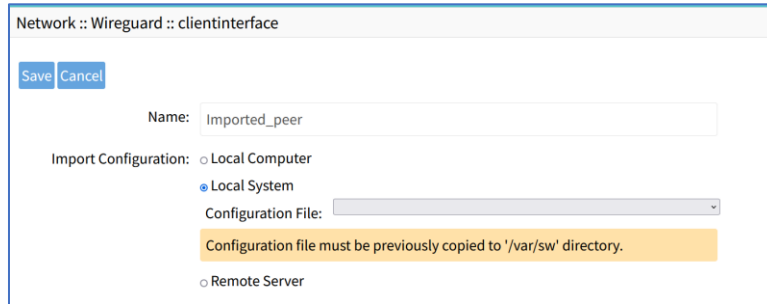

On the **Configuration File** drop-down, select one.

**Remote Server** radio button (expands dialog):

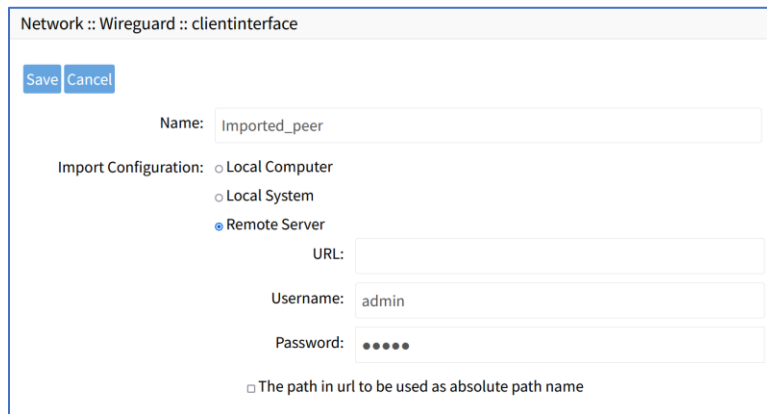

Enter **URL**

Enter **Username**

Enter **Password**

(optional) Select **The path in url to be used as absolute path name** checkbox.

5. Click **Save**.

## Start Tunnel

### WebUI Procedure

1. Go to *Network :: VPN drop-down :: Wireguard*.
2. On the table, select checkbox to start configuration.
3. Click **Start Tunnel**.

## Stop Tunnel

### WebUI Procedure

1. Go to *Network :: VPN drop-down :: Wireguard*.
2. On the table, select checkbox to stop configuration.
3. Click **Stop Tunnel**.

# Managed Devices Section

In this section, users can configure, create, and delete devices. The Nodegrid Platform supports devices connected through a serial, USB, or network connection.

## General Information

### *Supported Protocols*

These protocols are currently supported for network-based devices:

- Telnet
- SSH
- HTTP/S
- IPMI variations
- SNMP

Devices are managed with multiple options (enable, create, add). These can be done manually or automatically with Discovery.

When a managed device is added in the System, one license is pulled from the License Pool. Each unit is shipped with enough perpetual licenses for all physical ports. Additional licenses can be added to a unit to manage additional devices.

If licenses expire or are deleted from the system, the status of any device that exceeds the total licenses is changed to “Unlicensed”. The System maintains information on unlicensed devices but are only shown on the *Access* page. Licensed devices are listed and available for access and management. On the *Managed Devices* page (upper right), total licenses, total in-use licenses, and total available licenses are shown.

### *Device Types*

These managed device types are supported:

- Console connections that utilize RS-232 protocol.
  - Nodegrid Console Servers
  - Nodegrid Net Services Routers
- Service Processor Devices that use:
  - IPMI 1.5
  - IPMI 2.0
  - HP iLO
  - Oracle/SUN iLOM

IBM IMM

Dell DRAC

Dell iDRAC

Intel BMC

- Console Server connections that utilize SSH protocol

- Console Server connections that utilize:

Vertiv ACS Classic family

Vertiv ACS6000 family

Lantronix Console Server family

Opengear Console Server family

Digi Console Server family

Nodegrid Console Server family

- KVM (Keyboard, Video, Mouse) Switches that utilize:

Vertiv DSR family

Vertiv MPU family

Atem Enterprise KVM family

Raritan KVM family

ZPE Systems KVM module

- Rack PDUs from:

APC

CPI

Cyberpower

Baytech

Eaton

Enconnex

Vertiv (PM3000 and MPH2)

Raritan

Ritttal

Servertech

- Cisco UCS

- Netapp

- Infrabox
- Virtual Machine sessions from:
  - VMWare
  - KVM
- Sensors:
  - ZPE Systems Temperature and Humidity Sensor
- EdgeCore Access Points

## Devices tab

These are all actions that can be performed on this page.

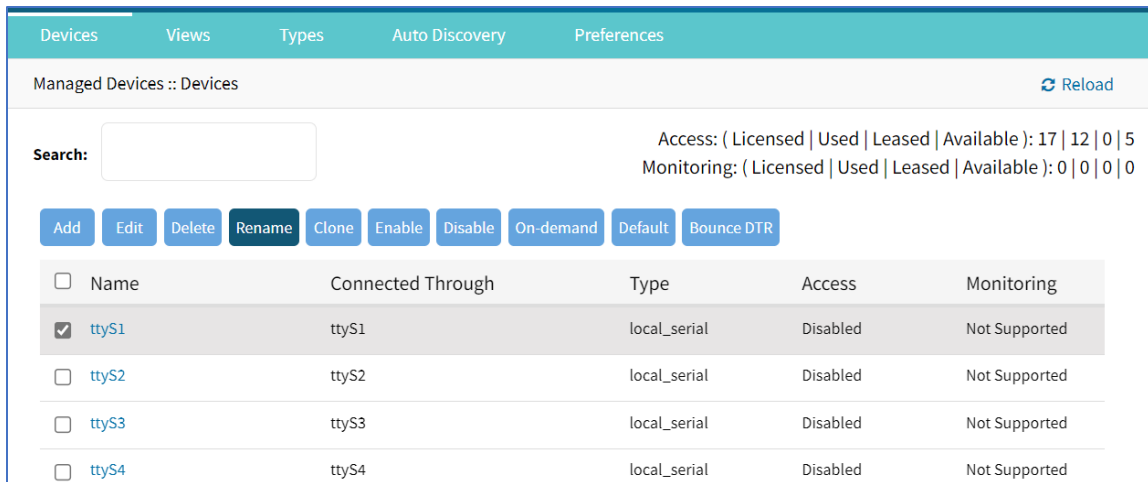

Name	Connected Through	Type	Access	Monitoring
<input checked="" type="checkbox"/> ttyS1	ttyS1	local_serial	Disabled	Not Supported
<input type="checkbox"/> ttyS2	ttyS2	local_serial	Disabled	Not Supported
<input type="checkbox"/> ttyS3	ttyS3	local_serial	Disabled	Not Supported
<input type="checkbox"/> ttyS4	ttyS4	local_serial	Disabled	Not Supported

**Page Quantity** button (right side) – on the drop-down (100, 250, 500, 750, 1000) to select the number of items to display on the page.

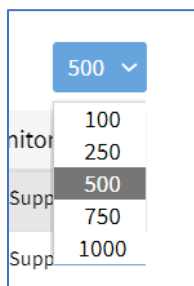

**Add** – add a device configuration.

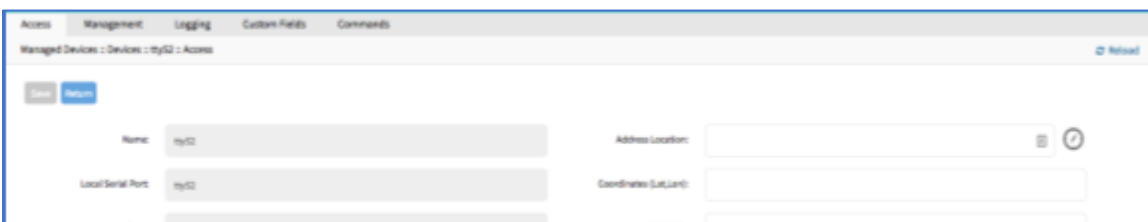

**Edit** – edit settings on the selected device

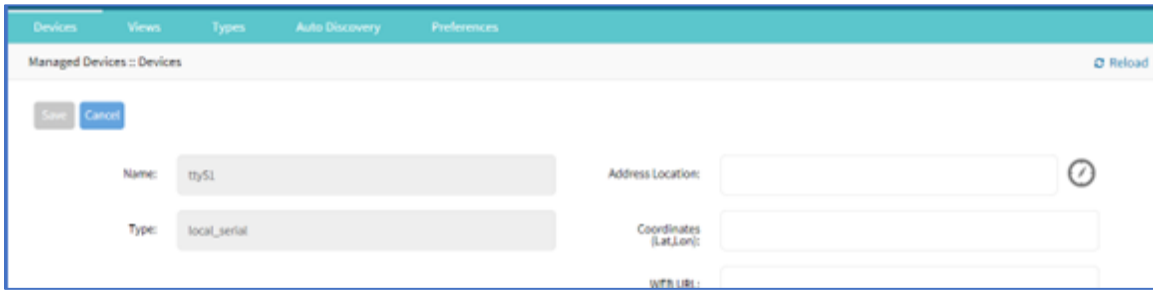

**Delete** – displays a pop-up delete confirmation dialog for the selected device

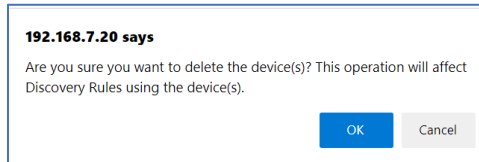

**Rename** – change name of selected device

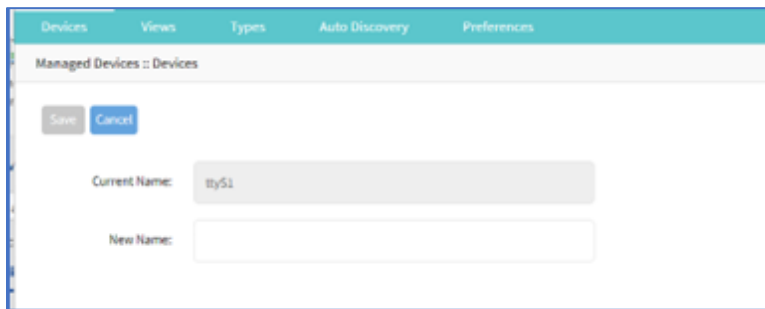

**Clone** – clone the selected device

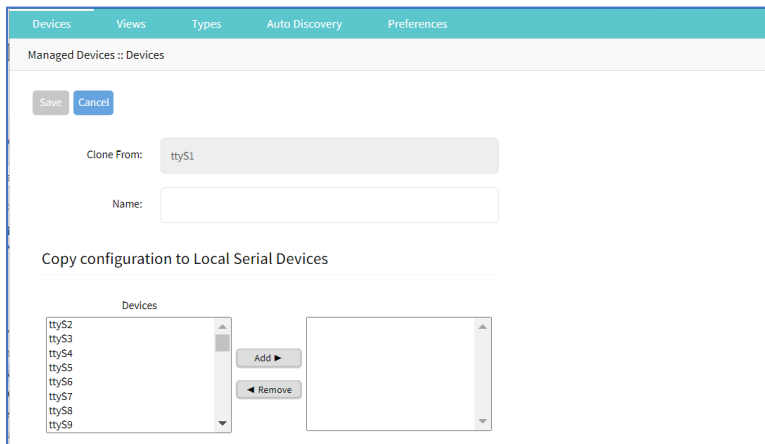

**Enable** – enables the selected device



<input type="checkbox"/>	Name	Connected Through	Type	Access	Monitoring
<input type="checkbox"/>	ttyS1	ttyS1	local_serial	Enabled	Not Supported
<input checked="" type="checkbox"/>	ttyS2	ttyS2	local_serial	Disabled	Not Supported

**Disable** – disables the selected device

<input type="checkbox"/>	Name	Connected Through	Type	Access	Monitoring
<input type="checkbox"/>	ttyS1	ttyS1	local_serial	Disabled	Not Supported
<input type="checkbox"/>	ttyS2	ttyS2	local_serial	Disabled	Not Supported

**On-demand** – changes selected device availability to On-Demand

<input type="checkbox"/>	Name	Connected Through	Type	Access	Monitoring
<input type="checkbox"/>	ttyS1	ttyS1	local_serial	On-demand	Not Supported
<input type="checkbox"/>	ttyS2	ttyS2	local_serial	Disabled	Not Supported

**Default** – make the selected device the default device

**Bounce DTR** – puts the DTR and RTS pins DOWN – waits 500ms, then put those pins UP.

## Device Types

When a device is added, the *Add* dialog is modified by the **Type** selection.

### Service Processor Devices

The Nodegrid Platform supports multiple IPMI-based Service Processors (IPMI 1.5, IMPI 2.0, Hewlett Packard ILO's, Oracle/SUN iLOM's, IBM IMM's, Dell DRAC and iDRAC).

To manage these devices, Nodegrid requires a valid network connection to each device. This can be without dedicated network interface on Nodegrid, or through an existing network connection.

These features are available:

- Serial Over LAN (SOL)
- Web Interface

- KVM sessions
- Virtual Media
- Data Logging
- Event Logging
- Power Control (through Rack PDU)

Some features might not be available, depending on the Service Processor capabilities.

For console access via SOL, on the server make sure to enable BIOS console redirect and OS console redirect (typically for Linux OS).

### Infrabox

Smart Access Control is supported for Rack's solution appliances (Infrabox) from InfraSolution. Communication requires SNMP to be configured.

These features are available:

- Door Control
- Web Session
- Power Control through Rack PDU

### Netapp

Netapp appliances are supported through their management interfaces. These features are available:

- Console Session
- Data Logging
- Event Logging
- Power Control through Netapp appliance
- Web Session
- Custom Commands
- Power Control through Rack PDU

### Cisco UCS

Management of Cisco UCS is supported through Console Ports, as well as management interfaces. These features are available:

- Console Session
- Data Logging
- Event Logging
- Power Control through Cisco UCS appliance
- Web Session

- Custom Commands

## Devices with SSH

Management of devices through SSH is supported:

These features are available:

- Console Session
- Data Logging
- Custom Commands
- Web Sessions
- Power Control through Rack PDU

## Third-Party Console Servers

Multiple third-party Console Servers from different vendors are supported (including consoles from Avocent and Servertech). These can be added to allow connected targets to be directly connected to a Nodegrid device.

This is a two-step process, First, the third party unit is added to the Nodegrid Platform. Then all enabled ports are added to the Nodegrid Platform.

These features are available:

- Console Session
- Data Logging
- Custom Commands
- Web Sessions
- Power Control through Rack PDU

## Rack PDUs

Multiple third-party Rack PDUs from different vendors are supported. (including products from APC, Avocent, Baytech, CPI, Cyberpower, Eaton, Enconnex, Geist, Liebert, Raritan, Rittal, and Servertech). When these devices are added to the Nodegrid Platform, users can connect to the Rack PDU and control the power outlets (only if supported by the Rack PDU). Outlets can be associated to specific devices, allowing direct control of specific power outlets for this device.

These features are available:

- Console Sessions
- Data Logging
- Custom Commands
- Web Sessions
- Power Control of outlets

The Power Control feature needs to be supported by the Rack PDU. Check the Rack PDU manual to determine if this feature is available on a specific model.

**NOTE:** By default, Nodegrid communicates with the Rack PDU with SSH/telnet. The reaction time is typically very slow. If possible, use SNMP to communicate with the Rack PDU.

Rack PDUs include (other PDUs may be available on the list):

pdu\_apc

pdu\_baytech

pdu\_digital\_loggers

pdu\_eaton

pdu\_mph2

pdu\_pm3000

pdu\_cpi\_serial (must be physically connected via serial port or USB)

pdu\_raritan

pdu\_geist

pdu\_servertech

pdu\_enconnex

pdu\_cyberpower

pdu\_rittal

pdu\_tripplite

## KVM Switches

Multiple third party KVM switches are supported (including those from Avocent and Raritan). When added, the switches act as if directly connected.

This is a two-step process, First, the third-party KVM switch is added to the Nodegrid Platform. Then all enabled ports are added.

These features are available:

- KVM Session
- Web Sessions
- Power Control through Rack PDU

On the **Add** dialog, make sure these two settings are set:

For **End Point**, select **Appliance** radio button.

On **End Point**, select **KVM Port** radio button.

## ***Device Procedures***

### **Add Device**

**NOTE:** *Add* dialog changes based on **Type** drop-down selection.

#### ***WebUI Procedure***

1. Go to *Managed Devices :: Devices*,
2. Click **Add** (displays dialog).

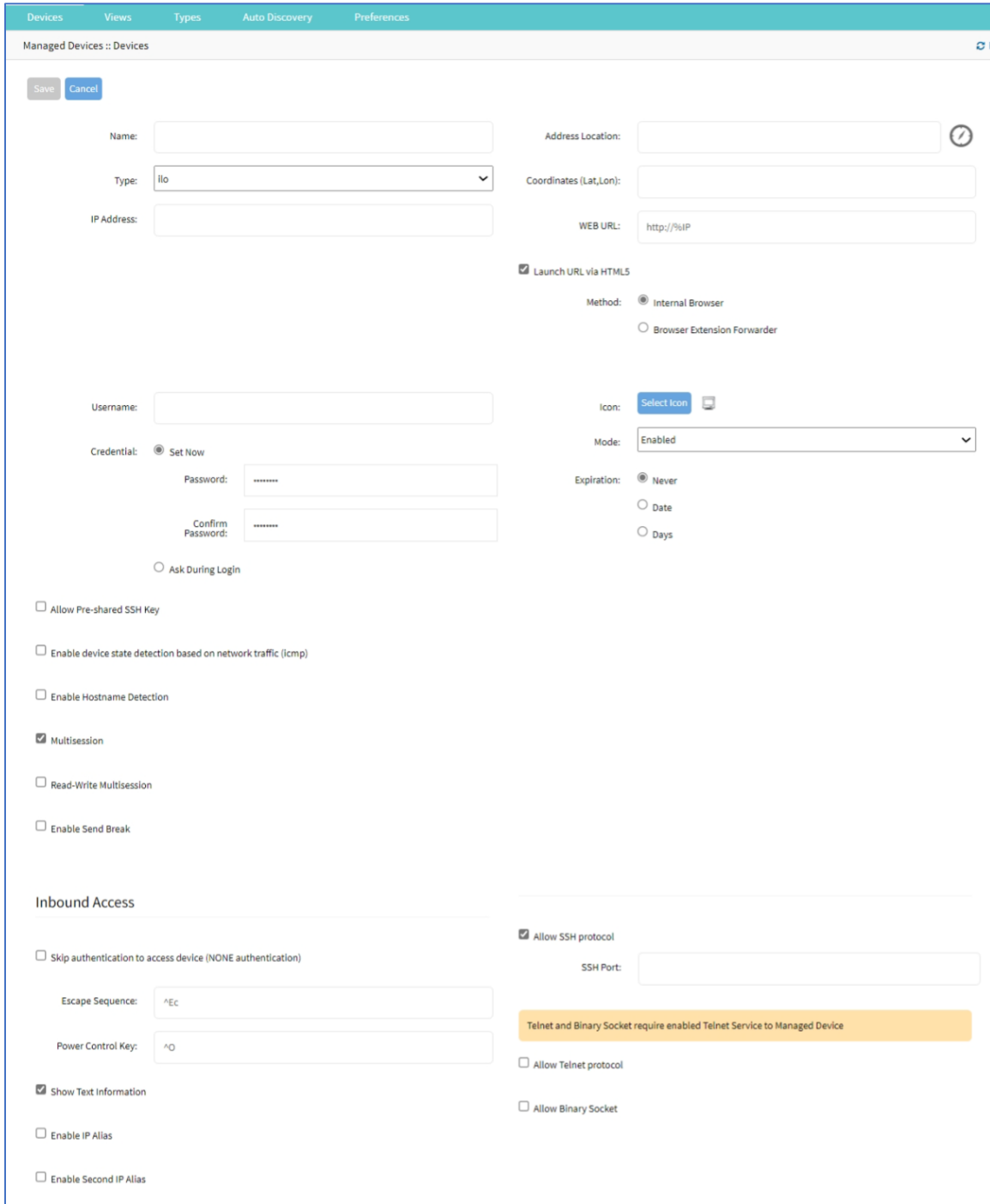

3. Enter the **Name** (of the server).
4. In the **Type** drop-down, select one (see options, based on selection).

+++++

Service Processor devices (ilo, imm, drac, drac6, idrac7, ilom, ipmi\_1.5, ipmi\_2.0, intel\_bmc)

Enter **IP Address** (reachable by the Nodegrid Platform).

+++++

Infrabox devices (infrabox)

Enter **IP Address** (reachable by the Nodegrid Platform).

+++++

Netapp devices (netapp)

Enter **IP Address** (reachable by the Nodegrid Platform).

+++++

Cisco UCS Blade devices (cimc\_ucs)

Enter **IP Address** (reachable by the Nodegrid Platform).

Enter the **Chassis ID**.

Enter the **Blade ID**.

+++++

Virtual Console KVM devices (virtual\_console\_kvm)

Enter **IP Address** (reachable by the Nodegrid Platform).

Enter **Port**.

+++++

Console Server devices (console\_server\_nodegrid, console\_server\_acs, console\_server\_acs6000, console\_server\_lantronix, console\_server\_opengear, console\_server\_digicp, console\_server\_raritan, console\_server\_perle)

Enter **IP Address** (reachable by the Nodegrid Platform).

Enter **Port**.

+++++

PDU devices (pdu\_apc, pdu\_baytech, pdu\_digital\_logger, pdu\_eaton, pdu\_mph2, pdu\_pm3000, pdu\_cpi, pdu\_raritan, pdu\_geist, pdu\_servertech, pdu\_enconnex, pdu\_cyberpower, pdu\_rittal)

Enter **IP Address** (reachable by the Nodegrid Platform).

+++++

KVM Virtual Machine devices (virtual\_console\_kvm)

**Name** must match the hypervisor name.

Enter **IP Address** (reachable by the Nodegrid Platform).

+++++

KVM devices (kvm\_dsr, kvm\_mpu, kvm\_aten, kvm\_raritan)

Enter **IP Address** (reachable by the Nodegrid Platform).

+++++

5. Enter **Address Location** (a valid address for the device location).

Enter **Coordinates (Lat, Lon)** (if GPS is available, click **Compass** icon – or manually enter GPS coordinates).

6. Enter **Web URL**.

7. Select **Launch URL via HTML5** checkbox (expands options).

In *Method* menu, select one:

**Internet Browser** radio button

**Browser Extension Forwarder** radio button (apply note instructions).

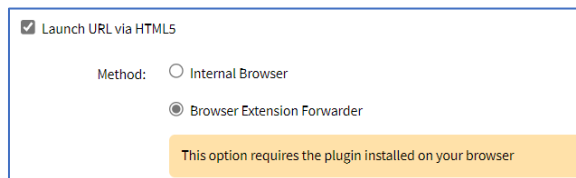

8. Enter **Username**

In *Credential* menu, select one:

**Set Now** radio button

Enter **Password** and **Confirm Password**.

**Ask During Login** radio button (user credentials are entered during login).

9. Select checkboxes, as needed:

**Allow Pre-shared SSH Key** checkbox.

**Enable device state detection based on network traffic (icmp)** checkbox.

**Enable Hostname Detection** checkbox.

**Multisession** checkbox.

**Read-Write Multisession** checkbox.

**Enable Send Break** checkbox.

10. Click **Select Icon** .On the pop-up dialog, select an icon.



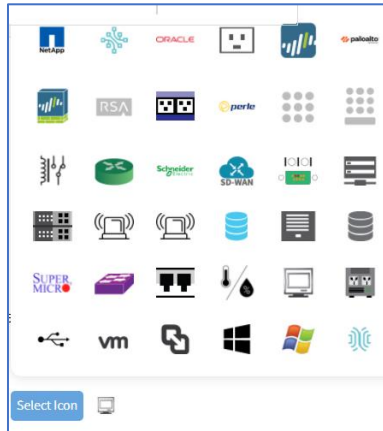

11. On **Mode** drop-down, select one (**Enabled, On-demand, Disabled**).

12. In *Expiration* menu, select one:

**Never** radio button

**Date** radio button

Enter **Date (YYYY-MM-DD)**.

**Days** radio button

Enter **Duration**.

13. In *End Point* menu, select one (*not available for service processors, virtual consoles*);

**Appliance** radio button

**Serial Port** radio button

Enter **Port Number**.

**KVM Port** radio button

Enter **Port Number**.

14. In *Inbound Access* menu:

Select **Skip Authentication to access device (NONE authentication)** checkbox (if unselected, enter the following details).

Enter **Escape Sequence**.

Enter **Power Control Key**.

Select **Show Text Information** checkbox.

Select **Enable IP Alias**.



Enter **IP Address**.

On **Interface** drop-down, select one (**eth0, eth1, loopback, loopback1**).

On **Browser Action** drop-down, select one (**console, web**).

Select **Allow Telnet Protocol**.

Enter **TCP Socket Port**.

Select **Allow Binary Socket**.

Enter **TCP Socket Port**.

(optional) Select **Enable Second IP Alias** checkbox.

Enter **IP Address**.

On **Interface** drop-down, select one (**eth0, eth1, loopback, loopback1**).

On **Browser Action** drop-down, select one (**console, web**).

Select **Allow Telnet Protocol**.

Enter **TCP Socket Port**.

Select **Allow Binary Socket**.

Enter **TCP Socket Port**.

Select **Allow SSH protocol**.

Enter **SSH Port**.

At this location:

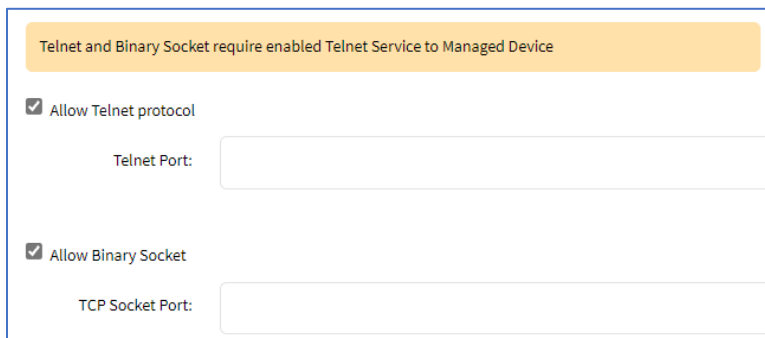

Select **Allow Telnet Protocol**.

Enter **TCP Socket Port**.

Select **Allow Binary Socket**.

Enter **TCP Socket Port**.

15. Click **Save**.

#### CLI Procedure

1. Go to /settings/devices.
2. Use the add command to create a new device.
3. Use the set command to define the following settings:

name

type

ip\_address

username and password (of service processor)  
or set credential ask\_during\_login

4. Save the changes with commit.

```
[admin@nodegrid /]# cd /settings/devices
[admin@nodegrid devices]# add
[admin@nodegrid {devices}]# set name=IPMI
[admin@nodegrid {devices}]# set type=ipmi_2.0
[admin@nodegrid {devices}]# set ip_address=192.168.10.11
[admin@nodegrid {devices}]# set credential=ask_during_login

or

[admin@nodegrid {devices}]# set credential=set_now
[admin@nodegrid {devices}]# set username=admin password=admin

[admin@nodegrid {devices}]# commit
```

## Configure Rack PDU

This requires two steps.

1. Add the PDU device. See *Add Device*.
2. Configure the PDU with the procedure below.

#### WebUI Procedure

1. Go to *Managed Devices :: Devices*.
2. Locate and click the **Name** of the newly added Rack PDU.
3. On the **Commands** tab, *Command* column, click **Outlets**.

Command	Command Status	Protocol	Protocol Status
<input type="checkbox"/> Console	Enabled	SSH	Enabled
<input type="checkbox"/> Data Logging	Disabled	None	Not Applicable
<input type="checkbox"/> Outlet	Enabled	SSH	Enabled
<input type="checkbox"/> Web	Enabled	HTTP/S	Enabled

4. On the **Protocol** drop-down, select **SNMP**.

5. Click **Save**.

Managed Devices :: Devices :: Rack\_PDU :: Commands

Save Return

Command: Outlet

Enabled

Protocol: SNMP

The command will only be available if the protocol it uses is enabled under management.

6. On the **Management** tab:

In the *SNMP* menu, update values to match the Rack PDU settings (see manufacturer’s manual).

7. Click **Save**.

**NOTE:** Use SNMP settings to provide read and write access. Read-Only credentials can not control power outlets.

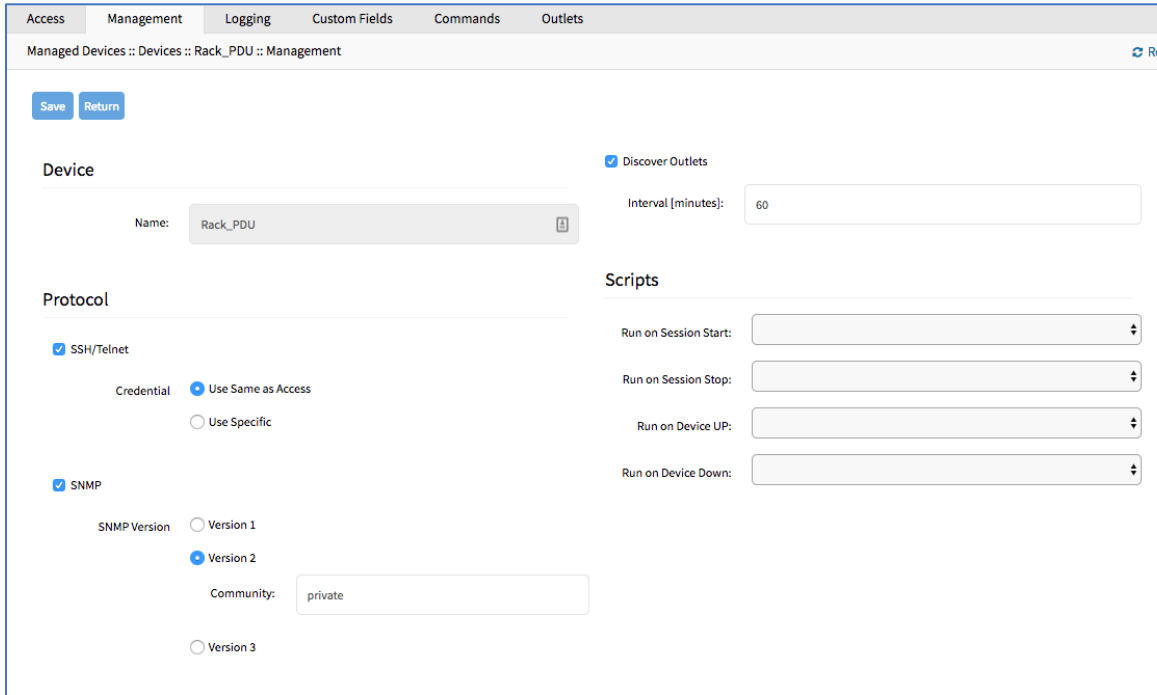

8. The Rack PDU Outlets are automatically discovered (may need a few minutes, depending on the Rack PDU).

### CLI Procedure

1. Go to `/settings/devices/<device name>/commands/outlet`.
2. Change the protocol to SNMP.
3. Go to `/settings/devices/<device name>/management`.
4. Enable SNMP and select the desired SNMP version and details.
5. Save the changes with commit.

**NOTE:** Use SNMP settings to provide read and write access. Read-Only credentials can not control power outlets.

6. The Rack PDU Outlets are automatically discovered (may need a few minutes, depending on the Rack PDU).

```
[admin@nodegrid /]# cd /settings/devices
[admin@nodegrid devices]# add
[admin@nodegrid {devices}]# set name=Rack_PDU
[admin@nodegrid {devices}]# set type=pdu_servertech
[admin@nodegrid {devices}]# set ip_address=192.168.2.39
[admin@nodegrid {devices}]# set credential=ask_during_login
```

or

```
[admin@nodegrid {devices}]# set credential=set_now
```

```
[admin@nodegrid {devices}]# set username=admin password=admin

[admin@nodegrid {devices}]# commit
[admin@nodegrid /]# cd /settings/devices/Rack_PDU/commands/outlet
[admin@nodegrid outlet]# set protocol=snmp
[admin@nodegrid outlet]# cd /settings/devices/Rack_PDU/management/
[admin@nodegrid management]# set snmp=yes
[+admin@nodegrid management]# snmp_version = v2
[+admin@nodegrid management]# snmp_community = private
[+admin@nodegrid management]# commit
```

## Edit Device

### WebUI Procedure

1. Go to *Managed Devices :: Devices*.
2. In the *Name* column, locate device and select checkbox.
3. Click **Edit** (displays dialog).
4. Make changes, as needed.
5. Click **Save**.

## Delete Device

### WebUI Procedure

1. Go to *Managed Devices :: Devices*.
2. In the *Name* column, locate device and select checkbox.
3. Click **Delete**.
4. On confirmation pop-up dialog, click **OK**.

## Rename Device

### WebUI Procedure

1. Go to *Managed Devices :: Devices*.
2. In the *Name* column, locate device and select checkbox.
3. Click **Rename** (displays dialog).

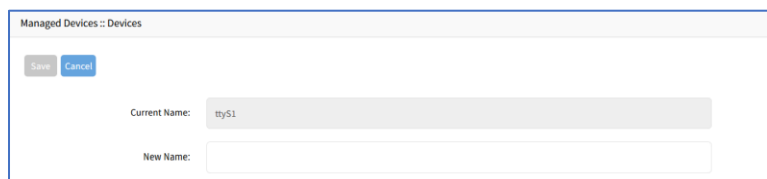

4. Enter **New Name**.
5. Click **Save**.

## Clone Device

### WebUI Procedure

1. Go to *Managed Devices :: Devices*.
2. In the *Name* column, locate device and select checkbox.
3. Click **Clone** (displays dialog).

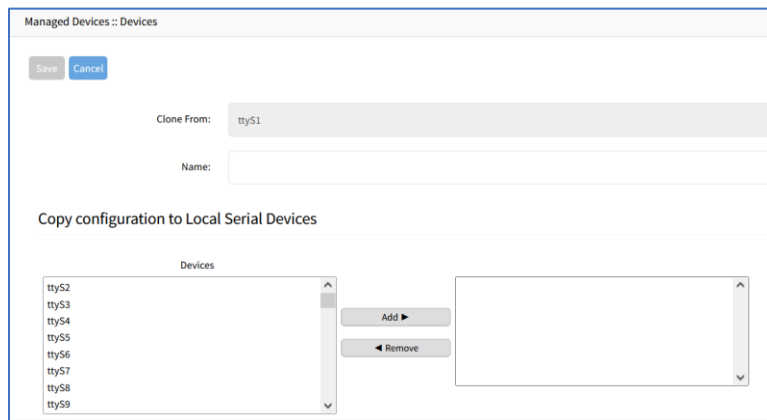

4. Enter **Name**.
5. In *Copy configuration to Local Serial Devices* section:  
 Select from left-side panel, click **Add ►** to move to right-side panel.  
 To remove from right-side panel, select, and click **◀ Remove**.
6. Click **Save**.

## Enable/Disable Device

### WebUI Procedure

1. Go to *Managed Devices :: Devices*.
2. In the *Name* column, locate device and select checkbox.
3. Click **Enable**. (to enable device).
4. Click **Disable** (to disable device).

## Set Device to On-Demand

### WebUI Procedure

1. Go to *Managed Devices :: Devices*.
2. In the *Name* column, locate device and select checkbox.
3. Click **On-Demand**.

## Set Device as Default

**WARNING:** This restores the selected device back to it's original factory settings.

**WebUI Procedure**

1. Go to *Managed Devices :: Devices*.
2. In the *Name* column, locate device and select checkbox.
3. Click **Default**.

**Run Bounce DTR**

This puts the DTR and RTS pins DOWN – waits 500ms, then put those pins UP.

**WebUI Procedure**

1. Go to *Managed Devices :: Devices*.
2. In the *Name* column, locate device and select checkbox.
3. Click **Bounce DTR**.

**Configure Chatsworth (CPI) eConnect PDU**

This unit must be physically connected to a serial port or USB port of a Nodegrid device. This PDU can merge IT devices to PDU outlets for more intuitive power control. Console access is included. Activities are recorded on the serial data log. Features include Outlet Auto Discovery and Outlet Control (Power On, Off, Cycle, Status).

**NOTE:** Console + CLI should be available on the PDU device - find your model in the [CPI Quick Reference](#).

**WebUI Procedure**

1. Go to *Managed Devices :: Devices*.
2. Click on the serial device the PDU is connected.

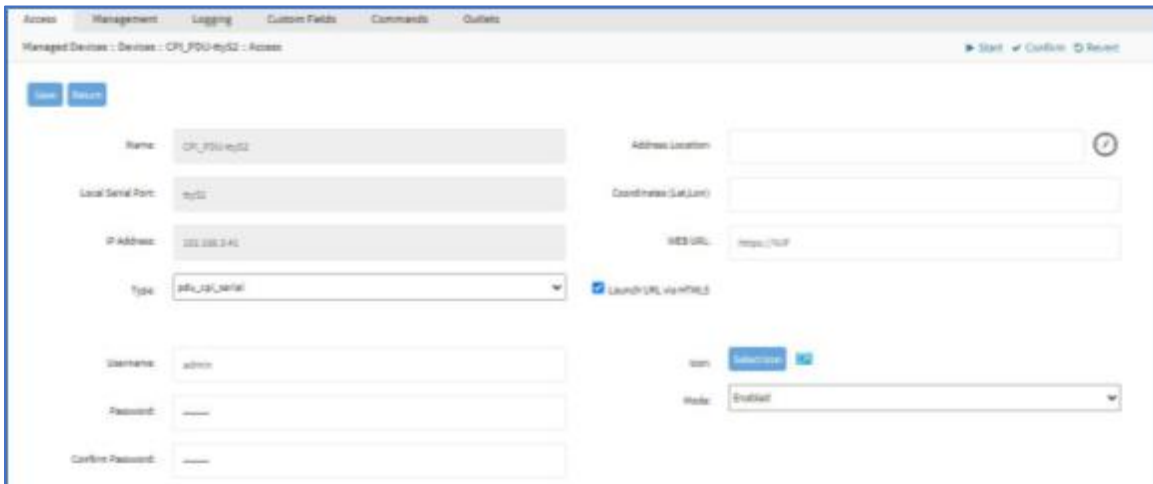

3. On **Type** drop-down, select **pdu\_cpi\_serial**.
4. Enter **Username**.
5. Enter **Password** and **Confirm Password**.



6. (as needed) Review and adjust serial configuration details (**Baud Rate, Parity, etc.**)
7. Click **Save**.

### Auto Discovery

Auto-Discovery automatically detects the CPI PDU. The CPI PDU details are available in device's **Outlets** sub-tab.

If not automatically discovered

1. Go to *Auto-Discovery :: Discover Now*.
2. Select **PDU serial device name** checkbox.
3. Click **Discover Now**.
4. To confirm, go to *Access :: Table*.
5. Click on the **PDU serial device name** and check the *Discovered Outlets* in the table.

### Merged Outlets

To see merged outlets.

1. Go to *Managed Devices :: Devices :: <device name> :: Commands*.
2. Review *Merged* panel details (this example shows eConnect PDU attached with two devices).

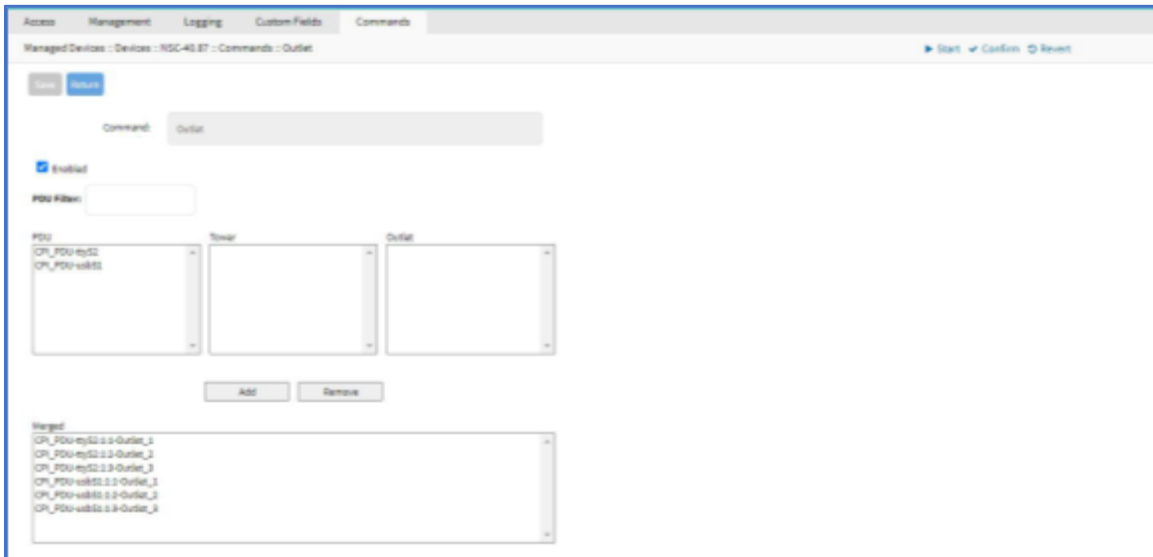

## Configure Individual Device Settings

Each device in the *Managed Devices :: Devices* table are individually configured. To gain access to a device's settings, locate it in the table, and click the **Name**. This displays the individual device settings in sub-tabs: **Access, Management, Logging, Custom Fields, Commands**.

Devices	Views	Types	Auto Discovery	Preferences
Access	Management	Logging	Custom Fields	Commands
Managed Devices :: Devices :: ttyS2 :: Access				

In the procedures, the path is shown as:

Go to *Device Management :: Devices :: <device name> :: <sub-tab>*.

Alternately, select the checkbox next to the device name and click **Edit**.

## Access sub-tab

The Nodegrid Platform supports RS-232 Serial connections with the available Serial and USB interfaces. Ports are automatically detected and shown in the Devices menu. To provide access to the device, each port needs to be enabled and configured.

Before configuring the Nodegrid port, check the device manufacturer's console port settings. Most devices use default port settings: 9600,8,N,1

The Nodegrid Console Server S Series supports advanced auto-detection. This simplifies configuration with automatic detection of the cable pinout (Legacy and Cisco) and connection speed.

## Configure Device Type

This is a general description of the procedure. Based on type of device, the details will change. Details provided here is the serial port configuration.

### WebUI Procedure

1. Go to *Managed Devices :: Devices :: <device name> :: Access*.

Access
Management
Logging
Custom Fields
Commands

Managed Devices :: Devices :: ttyS1 :: Access

Save
Return

Name:

Local Serial Port:

Type:

Allow Pre-shared SSH Key

Baud Rate:

Parity:

Flow Control:

Data Bits:

Stop Bits:

RS-232 signal for device state detection:

Enable device state detection based in data flow

Enable Hostname Detection

Multisession

Read-Write Multisession

Enable Serial Port Settings via Escape Sequence

**Inbound Access**

Skip authentication to access device (NONE authentication)

Escape Sequence:

Power Control Key:

Show Text Information

Enable IP Alias

Enable Second IP Alias

Address Location:  

Coordinates (Lat,Lon):

WEB URL:

Launch URL via HTMLS

Icon:

Mode:

Allow SSH protocol

SSH Port:

Telnet and Binary Socket require enabled Telnet Service to Managed Device

Allow Telnet protocol

Telnet Port:

Allow Binary Socket

2. Configure location details:

Enter **Address Location** (can use **Compass** icon).

Enter **Coordinates**.

Enter **Web URL**.

Select **Launch URL via HTML5** checkbox (default: enabled).

3. Select **Allow Pre-shared SSH Key** checkbox.

4. Configure port settings:

On **Baud Rate** drop-down, select one (speed matching device settings) or (**Auto, 9600, 19200, 38400, 57600, 115200**)..

On **Parity** drop-down, select one (**None**-default, **Odd, Even**).

On **Flow Control** drop-down, select one (**None**-default, **Software, Hardware**).

On **Data Bits** drop-down, select one (**5,6,7,8**-default).

On **Stop Bits** drop-down, select one (**1**-default, **2**).

On **RS-232 signal for device state detection** drop-down, select one (**Auto, DCD, CTS, None**).

5. Serial settings:

Select **Enable device state detection based in data flow** checkbox.

Select **Enable Hostname Detection** checkbox.

Select **Multisession** checkbox (Several users can access the same device at the same time, and see the same output. First user has read-write access, others have read-only.).

Select **Read-Write Multisession** checkbox (If enabled, all connected users have read-write access to the session).

Select **Enable Serial Port Settings via Escape Sequence** checkbox.

(optional) Select **Enable Send Break** (This is configured per device. Not available on: usb\_kvm, usb\_sensor, usb\_device, local\_serial).

If selected, enter a new **Break Sequence** (this is sent via the SSH console session).

6. Click **Select Icon** .On the pop-up dialog, select an icon.

7. On **Mode** drop-down, select one (**Enabled, On-Demand, Disabled**).

8. In the *Expiration* menu, select radio button for: **Never, Expiration Date** or **Expiration Days** and provide an appropriate value.

**NOTE:** With VM devices, both Date and Days are synced with the ESXi Servers where the VMs are constantly being added, moved, and deleted, or if the Nodegrid managed device license becomes available.

**Date (YYYY-MM-DD)** The device is available until the specified date. After that date, it is set to Disabled mode, and the admin user has 10 days to take action. After 10 days, the device and its data is removed from the system.

**Days** (between 1 and 999999999) If no update on the device's configuration after the specified days, the device and its data is removed from the System (similar to a timeout).

9. In *Inbound Access* menu:

Select **Skip authentication to access device (NONE authentication)** checkbox (displays dialog).

Skip authentication to access device (NONE authentication)

Skip in SSH sessions

Skip in Telnet sessions

Skip in Raw sessions

Skip in Web sessions

Select **Skip in SSH sessions** checkbox (default: enabled).

Select **Skip in Telnet sessions** checkbox (default: enabled).

Select **Skip in Raw sessions** checkbox (default: enabled).

Select **Skip in Web sessions** checkbox (default: enabled).

Enter **Escape Sequence** (default: ^Ec – Ctrl+Shift+E+c).

Enter **Power Control Key** (default: ^O – Ctrl+Shift+O).

Select **Show Text Information** checkbox.

Select **Enable IP Alias** checkbox (user can connect to a device with IP addresses).

Enable IP Alias

IP Address:

Interface:

Browser Action:

Allow Telnet Protocol

TCP Socket Port:

Allow Binary Socket

TCP Socket Port:

Enter **IP Address**.

On **Interface** drop-down, select one (**backplane0, eth0, loopback**).

On **Browser Action** drop-down, select one (**console, web**).

Select **Allow Telnet Protocol**. Enter **TCP Socket Port** (default: 23).

Allow Telnet Protocol

TCP Socket Port:

Select **Allow Binary Socket** checkbox. Enter **TCP Socket Port**.

Allow Binary Socket  
 TCP Socket Port:

Select **Enable Second IP Alias** checkbox (same dialog as **Enable IP Alias**).

Select **Allow SSH protocol** checkbox. Enter **SSH Port**.

Allow SSH protocol  
 SSH Port:

Select **Allow Telnet protocol** checkbox. Enter **Telnet Port**.

Allow Telnet protocol  
 Telnet Port:

Select **Allow Binary Socket** checkbox. Enter **TCP Socket Port**.

Allow Binary Socket  
 TCP Socket Port:

10. Click **Save**.

**CLI Procedure**

This example provides some of the configurations provided above.

1. Go to /settings/devices
2. Use the edit command with the port name to change the port configuration. Multiple ports can be defined.
3. Use the show command to display current values.
4. Use the set command for:
  - baud\_rate (set to the correct speed matching device settings or to Auto)
  - parity (None (default), Odd, or Even)
  - flow\_control (None (default), Software, Hardware)
  - data\_bits (5, 6, 7, 8 (default))
  - stop\_bits (1)
  - rs-232\_signal\_for\_device\_state\_detection (DCD (default), None, CTS)
  - mode (Enabled, On-Demand, Disabled)
5. Use the commit command to change the settings.

```
[admin@nodegrid /]# cd /settings/devices
[admin@nodegrid devices]# edit ttyS2
[admin@nodegrid {devices}]# show
name: ttyS2
type: local_serial
address_location =
coordinates =
web_url =
launch_url_via_html5 = yes
baud_rate = 9600
parity = None
flow_control = None
data_bits = 8
stop_bits = 1
rs-232_signal_for_device_state_detection = DCD
enable_device_state_detection_based_in_data_flow = no
enable_hostname_detection = no
multisession = yes
read-write_multisession = no
icon = terminal.png
mode = disabled
skip_authentication_to_access_device = no
escape_sequence = ^Ec
power_control_key = ^O
show_text_information = yes
enable_ip_alias = no
enable_second_ip_alias = no
allow_SSH_protocol = yes
SSH_port =
allow_telnet_protocol = yes
telnet_port = 7002
allow_binary_socket = no
data_logging = no
[admin@nodegrid {devices}]# set mode=enabled baud_rate=Auto
[admin@nodegrid {devices}]# commit
```

## Configure USB Mode

### WebUI Procedure

1. To confirm the USB card supports USB Passthrough, go to *System :: Slots :: Supported cards* . Check the *Add-ons* column for an entry: **Power Control**.

Slot Number	Card SKU	Card Type	Add-ons
slot-1	NSR-16USB-EXPN	NSR 16-Port USB Type A Expansion Card	Power Control
slot-2	NSR-16ETH-EXPN	NSR 16-Port 1G Ethernet Expansion Card	
slot-3	NSR-16USB-EXPN	NSR 16-Port USB Type A Expansion Card	
slot-4	NSR-M2-EXPN	NSR M.2 / SATA Expansion Card	M2-CELL   M2-CELL
slot-5	Empty	Empty	

2. Go to *Managed Devices :: Devices*.
3. On the list, locate the USB and click the **Name** (displays dialog).
4. On the **Access** tab, *USB Mode* menu:

Slot Number	Card SKU	Card Type	Add-ons
slot-1	NSR-16USB-EXPN	NSR 16-Port USB Type A Expansion Card	Power Control
slot-2	NSR-16ETH-EXPN	NSR 16-Port 1G Ethernet Expansion Card	
slot-3	NSR-16USB-EXPN	NSR 16-Port USB Type A Expansion Card	
slot-4	NSR-M2-EXPN	NSR M.2 / SATA Expansion Card	M2-CELL   M2-CELL
slot-5	Empty	Empty	

Select **Host** radio button:

USB Mode:  Host

Initial State:

Passthrough

On **Initial State** drop-down, select one (**On**, **Off**, **Last State**).



**NOTE:** The device with an internal USB serial adapter provides the power for the adapter. Power control setting does not affect power to the USB.

Select **Passthrough** radio button:

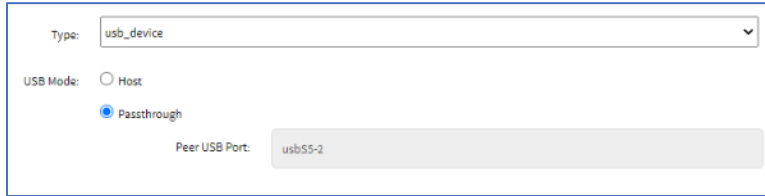

**NOTE:** When a device’s Passthrough mode is enabled, its peer is also set to Passthrough mode.

5. Click **Save**.

### Configure SSH Key Authentication

For added security, devices can be configured to authenticate via SSH keys. When enabled, SSH is connected with key pairs (user does not require password).

**NOTE:** Not all devices support this feature

#### Enable SSK Key Authentication WebUI Procedure

1. Go to *Managed Devices :: Devices :: <device name> :: Access*.
2. Select **Allow Pre-shared SSH Key** checkbox.

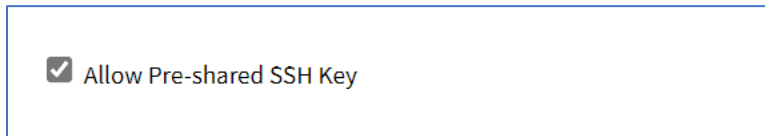

3. Click **Save**.

4. The **SSH Keys** button displays next to the **Save** and **Return** buttons.

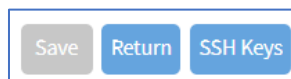

5. Click **SSH Keys** (displays dialog).



6. On **SSH Key Type** drop-down, select one (**ECDSA 521, ECDSA 384, ECDSA 256, ED25519, DSA 1024, RSA 4096, RSA 2048, RSA 1024**).
7. Click **Generate Pair Keys**.

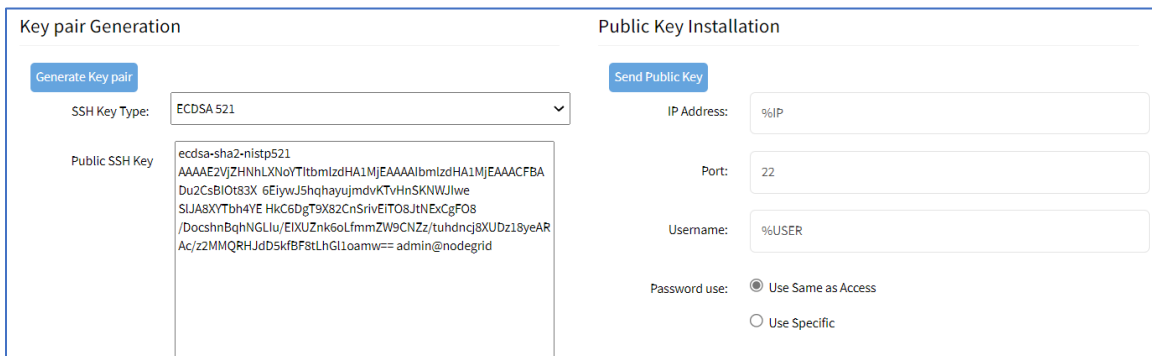

8. For **Password Use** setting, select **Use Same as Access** for the current account. Alternatively, select **Use Specific** and set new **Password** with **Confirm Password**.

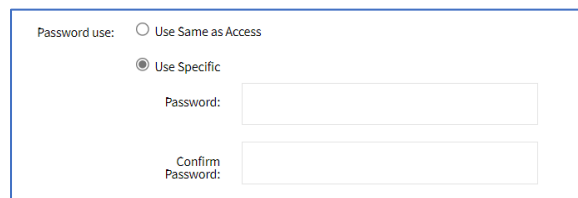

9. Click **Send Public Key** (sends key to the device). On a connection to a Managed Device with Pre-shared SSH Key enabled, username is still required. If the device fails to authenticate, at the prompt, enter the password. If an error message displays, resolve and click again.

**NOTE:** Not all devices support the **Send Public Key** feature. If not, manually copy the **Public SSH Key** textbox contents to the device.

10. Click **Return** (goes back to the **Access** sub-tab view).

### Enable Launch URL with Chrome Forwarder extension

(Chrome browser only) This requires Chrome Forwarder extension. This reduces resource usage by redirecting to a web server. This provides the same behavior as the HTML5 frame. The device's interface can be viewed in full-screen mode rather than a windowed frame.

#### Install Chrome Forwarder Extension and Activate

1. Open Google Chrome and go to <https://chrome.google.com/webstore/detail/nodegrid-web-access-exten/cmcpkbfnaqlakhlqgdmhkedpoengpik>
2. Click **Add to Chrome**.
3. When the extension is installed, go to *Managed Devices :: Devices :: <device name> :: Access*.
4. Select **Launch URL via Forwarder** checkbox.
5. Click **Save**.

### Management sub-tab

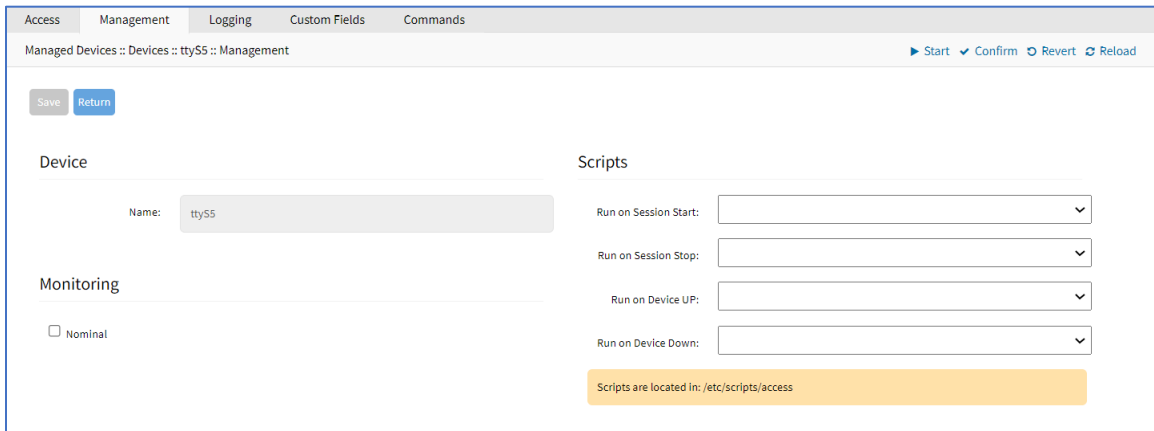

### Configure Management of Device

1. Go to *Managed Devices :: Devices :: <device name> :: Management*.
2. On *Device* menu, **Name** is read-only.
3. On *Monitoring* menu:
  - Select **Nominal** checkbox (expands dialog):

**Monitoring**

---

Nominal

Name:

Type:

Value:

Interval (s):

Enter **Name**.

On **Type** drop-down, select one (**Power, Apparent Power, Current, Voltage, Frequency, etc.**).

Enter **Value**.

Enter **Interval (s)** (default: 120).

- In the *Scripts* menu, select an available script for the appropriate device status drop-down list: Copy the scripts to `/etc/scripts/access` folder before assignment to a device status condition. Each script must be executable with user privileges. The customer or a professional services provider can create the custom script.

On **Run on Session Start** drop-down, select one.

On **Run on Session Stop** drop-down, select one.

On **Run on Device UP** drop-down, select one.

On **Run on Device Down** drop-down, select one.

- Click **Save**.

### Configure Discovery (Appliances only)

This configures the discovery process for the Appliance (i.e., Console Server).

#### WebUI Procedure

- Go to *Managed Devices :: Devices :: <device name> :: Management*.
- Scroll to this section.

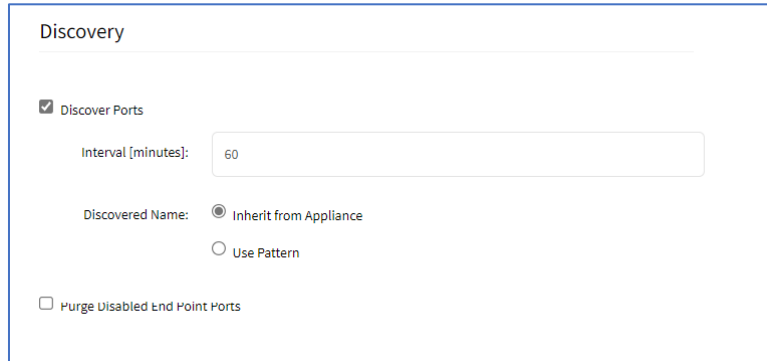

3. Select **Discovery Ports** checkbox.

Enter **Set Interval (minutes)**.

In *Discovered Name* menu, select one:

**Inherit from Appliance** radio button.

**Use Pattern** radio button.

4. (optional) Select **Purge Disabled End Point Ports** checkbox.

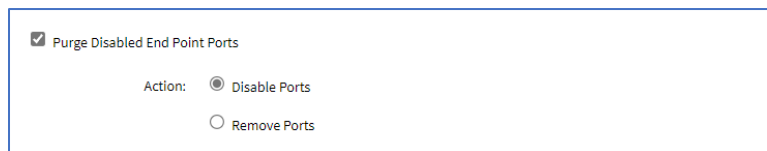

5. Click **Save**.

## Logging sub-tab

Data logs capture all session information sent and received from a device. This feature is available to log all text-based sessions (serial or SSH-based).

Data Logging and Event Logging can be configured to collect information and create event notifications, based on custom scripts triggered by events. Defined alert strings (simple text match or regular expression pattern) are evaluated against the data source stream (during data collection). Events are generated for each match.

**NOTE:** Custom scripts can be created by the customer or a professional services provider.

For data log events, copy scripts to the /etc/scripts/datalog folder. For event logs, copy scripts to /etc/scripts/events folder. Each script must be executable with user privileges.

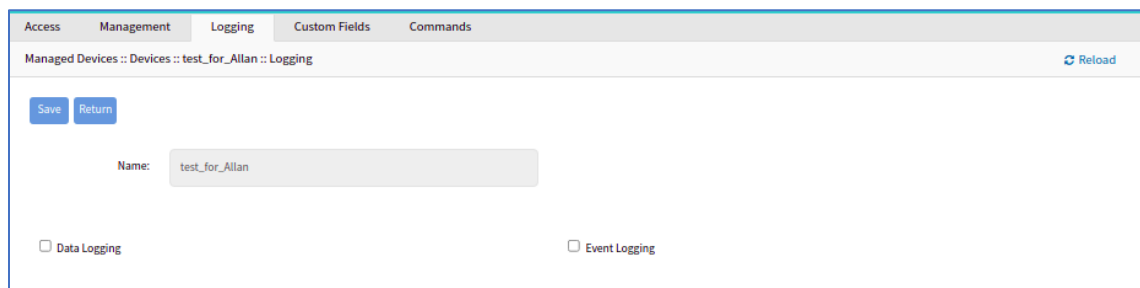

## Enable Data Logging and Triggered Alerts

Session data is recorded even if no user is connected. System messages are logged when pushed to console sessions. Location of data logs (local or remote) is based on Auditing settings.

### WebUI Procedure

1. Go to *Managed Devices :: Devices :: <device name> :: Logging*.
2. Scroll to this section.

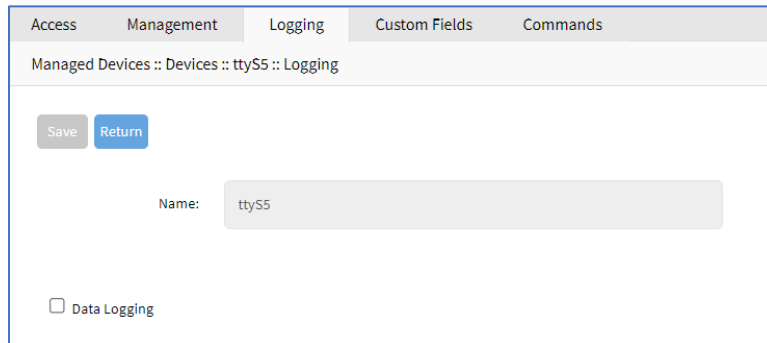

The screenshot shows the 'Logging' tab in the WebUI for a device named 'ttyS5'. At the top, there are tabs for 'Access', 'Management', 'Logging', 'Custom Fields', and 'Commands'. Below the tabs, the breadcrumb path is 'Managed Devices :: Devices :: ttyS5 :: Logging'. There are two buttons: 'Save' and 'Return'. A 'Name:' label is followed by a text input field containing 'ttyS5'. At the bottom, there is a checkbox labeled 'Data Logging' which is currently unchecked.

3. Select **Data Logging** checkbox (expands dialog).

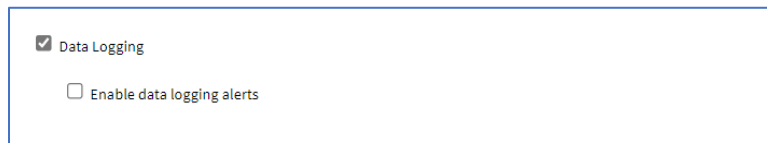

The screenshot shows the expanded 'Data Logging' dialog box. It contains two checkboxes: 'Data Logging' which is checked, and 'Enable data logging alerts' which is unchecked.

4. Select **Enable data logging alerts** checkbox (expands dialog).

Data Logging

Enable data logging alerts

Data String 1:

Data Script 1:

Data String 2:

Data Script 2:

Data String 3:

Data Script 3:

Data String 4:

Data Script 4:

Data String 5:

Data Script 5:

Scripts are located in: /etc/scripts/events

Enter **Data String 1** (that triggers alert).

On **Data Script 1** drop-down, select a script.

Repeat for additional triggers.

5. Click **Save**.

**CLI Procedure**

1. Go to /settings/devices/<device name>/logging
2. Use the set command to change the data\_logging value to yes.
3. Use the set command to change the enable\_data\_logging\_alerts value to yes.
4. Define for data\_string\_1 string or regular expression which will be matched against the data stream.
5. Define for data\_script\_1 an available script in case a custom script should be executed.
6. If needed, repeat for data\_string\_2 and data\_script\_2.
7. Save the changes with commit

```
[admin@nodegrid /]# /settings/devices/Device_Console_Serial/logging/
[admin@nodegrid /]#set data_logging=yes
[+admin@nodegrid logging]#set enable_data_logging_alerts=yes
[+admin@nodegrid logging]#set data_string_1="String"
[+admin@nodegrid logging]#set data_script_1=ShutdownDevice_sample.sh
```

```
[+admin@nodegrid logging]#commit
```

## Enable Event Logging and Triggered Alerts

**NOTE:** If *Event Logging* does not appear on the **Logging** sub-tab, it is not available on the selected device.

This feature logs events for Service Processor and IPMI sessions. When enabled, the System collects Service Processor Event Log data. The type of collected data depends on the Service Process functions and configuration.

The settings control the interval of collected information (# = 1-999, and time = minutes-hour). Location of data logs (local or remote) is based on *Auditing* section settings.

### WebUI Procedure

1. Go to *Managed Devices :: Devices :: <device name> :: Logging*.

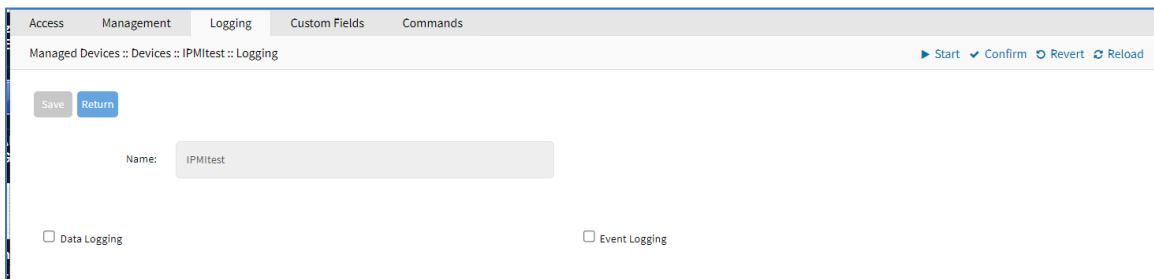

2. Select **Event Logging** checkbox (expands dialog).

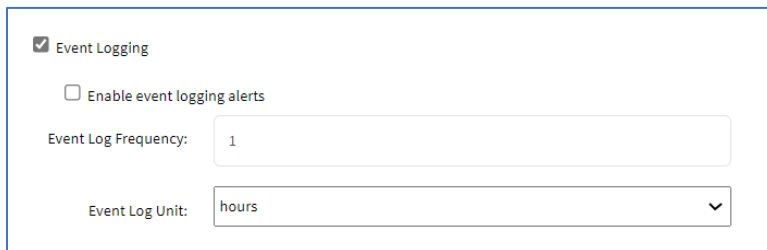

3. Select **Enable Event Logging Alerts** checkbox (expands dialog).



**Event Logging**

**Enable event logging alerts**

Event String 1:

Event Script 1:

Event String 2:

Event Script 2:

Event String 3:

Event Script 3:

Event String 4:

Event Script 4:

Event String 5:

Event Script 5:

Event Log Frequency:

Event Log Unit:

Enter **Event String 1** (that triggers alert).

On **Event Script 1** drop-down, select one.

Repeat for additional triggers.

4. Adjust **Event Log Frequency** (1 9999)
5. On **Event Log Unit** drop-down, select one (**hours, minutes**).
6. Click **Save**.

**CLI Procedure**

1. Go to /settings/devices/<device name>/logging
2. Use the set command to change the event\_logging value to yes
3. Use the set command to adjust event\_log\_frequency and event\_log\_unit as needed:  
 event\_log\_frequency range from 1 - 9999  
 event\_log\_unit options hours or minutes
4. Use the set command to change the enable\_event\_logging\_alerts value to yes
5. For event\_string\_1, define the text string or regular expression (to be matched against the data stream).
6. For event\_script\_1 define an available script (if a custom script should be executed).

7. As needed, define event\_string\_2 and event\_script\_2.
8. Save the changes with commit

```
[admin@nodegrid /]# /settings/devices/ipmi/logging/
[admin@nodegrid /]#set event_logging=yes
[+admin@nodegrid logging]#set event_log_frequency=1
[+admin@nodegrid logging]#set event_log_unit=hours
[+admin@nodegrid logging]#set enable_event_logging_alerts=yes
[+admin@nodegrid logging]#set event_string_1="String"
[+admin@nodegrid logging]#set event_script_1=PowerCycleDevice_sample.sh
[+admin@nodegrid logging]#commit
```

### Custom Fields sub-tab

Each device type has a collection of commands to access device of that type. Generally, the default configuration is sufficient and is the recommended option.

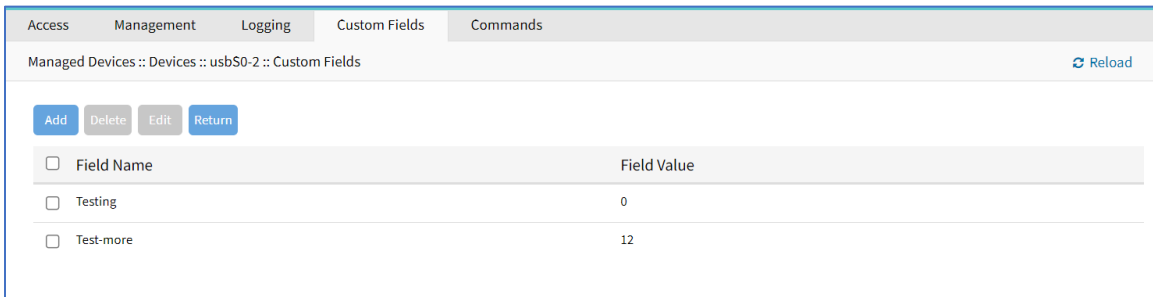

As needed, admin users can:

- Disable or change existing commands
- Enable any (by default) disabled commands
- Assign custom commands to a device
- Remove access to specific commands from certain users or groups (with user and group authorization)

Changes to the default command settings affect all users and require careful consideration.

Commands available depend on the device type. For example, the KVM command (enable Service Processor KVM session support) is only available to Service Processor devices. The Outlet command is available to all device types.

Custom Commands can be created with custom scripts, for all device types. Custom Commands can support for a wide range of different functions (such as additional session options and specific custom device tasks).

**NOTE:** Custom scripts can be created by the customer or a professional services provider.

### Add Custom Field

#### WebUI Procedure

1. Go to *Managed Devices :: Devices :: <device name> :: Custom Fields*.
2. Click **Add** (displays dialog).

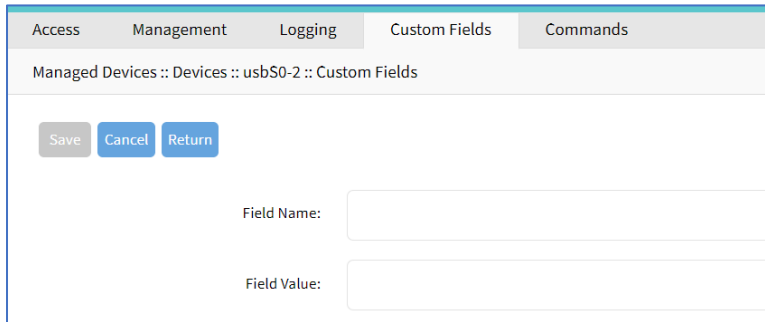

3. Enter **Field Name**.
4. Enter **Field Value**.
5. Click **Save**.

### Edit Custom Field

#### WebUI Procedure

1. Go to *Managed Devices :: Devices :: <device name> :: Custom Fields*.
2. Locate the custom field and select the checkbox.
3. Click **Edit** (displays dialog).

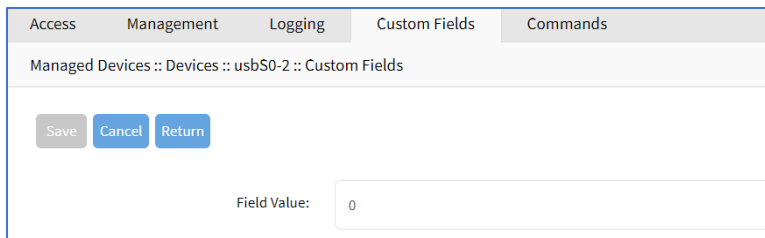

4. Edit the **Field Value**, as needed.
5. Click **Save**.

### Delete Custom Field

#### WebUI Procedure

1. Go to *Managed Devices :: Devices :: <device name> :: Custom Fields*.
2. Locate the custom field and select the checkbox.
3. Click **Delete**.
4. On confirmation pop-up dialog, click **OK**.

## Commands sub-tab

While Custom Commands can be executed through the WebUI and CLI, feedback and output of Custom Commands is only available on the CLI and not on the WebUI.

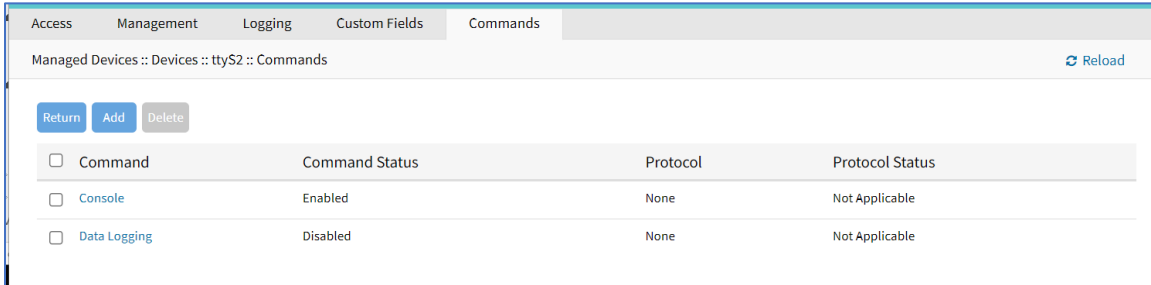

Command	Command Status	Protocol	Protocol Status
Console	Enabled	None	Not Applicable
Data Logging	Disabled	None	Not Applicable

## About Custom Scripts

Custom scripts required the following conditions:

- Written in Python

- “Command label” must match a function within the script

- Located in /etc/scripts/custom\_commands

Custom script example:

```
# FILE NAME: custom_command.py
import os
def shell_script_global_env(dev):
    # User variables
    int_var = 1234
    bool_var = False
    str_var = "Hello World"

    # Setting global environment variables
    # Use lower_case format names to not change system variables accidentally
    # Use string values
    os.environ['device_name'] = dev.device_name
    os.environ['device_ip'] = dev.ip
    os.environ['int_var'] = str(int_var)
    os.environ['bool_var'] = str(bool_var)
    os.environ['str_var'] = str_var

    shell_script_path = "/etc/scripts/custom_commands/echo_environment.sh"

    # Call shell script
    os.system(shell_script_path)
```

## Create Commands (Outlet, SSH, Telnet, Web)

This integrates Out-of-Band and Console-like configurations with the In-Band command.

### WebUI Procedure

1. Copy the custom script into /etc/scripts/custom\_commands
2. Go to *Managed Devices :: Devices :: <device name> :: Commands*.
3. Click **Add** (displays dialog).
4. In **Command** drop-down, select one (dialog changes depending on selection).
  - Outlet**. Enter details as needed.

Access Management Logging Custom Fields **Commands**

Managed Devices :: Devices :: ttyS2 :: Commands

Save Cancel Return

Command: Outlet

Enabled

PDU Filter:

PDU

Add Remove

Merged

Cycle Interval [seconds]: 3

**SSH.** Enter details as needed.

Access Management Logging Custom Fields **Commands**

Managed Devices :: Devices :: ttyS2 :: Commands

Save Cancel Return

Command: SSH

Enabled

Launch Local Application

SSH

User: %USER

IP Address:

Port Number: 22

**Telnet.** Enter details as needed.

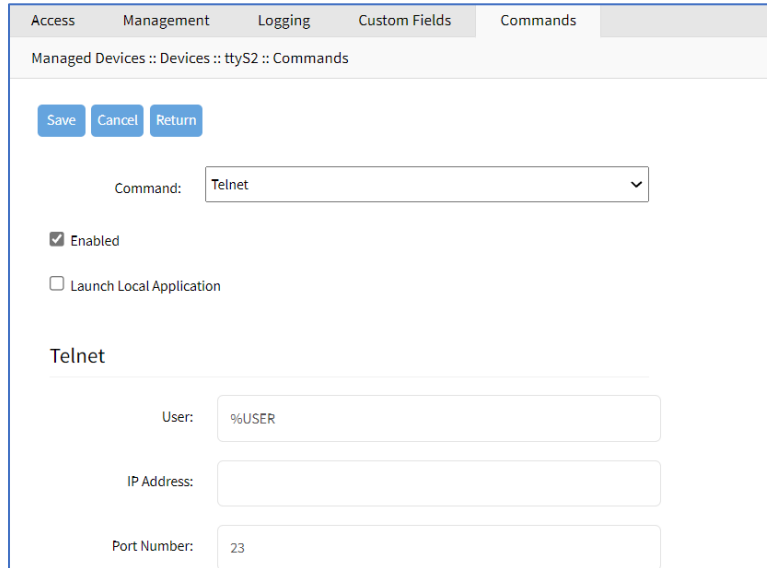

**Web** (if available). Select **Enabled** checkbox.

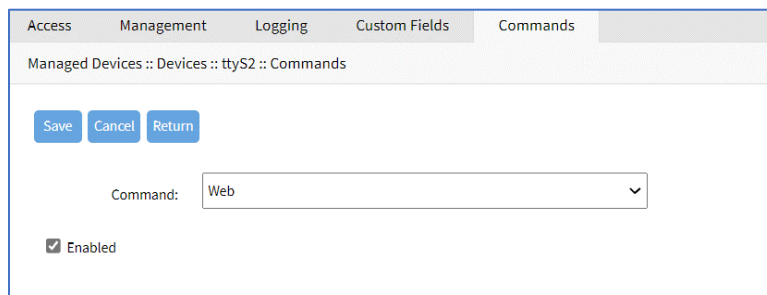

5. When done, click **Save**.

## Device Access via RDP

### WebUI Procedure

1. Go to *Managed Devices :: Devices :: <device name> :: Commands*.
2. Click **Add** (displays dialog).
3. In **Command** drop-down, select **KVM**.
4. Select **Enabled** checkbox.
5. On **Protocol** drop-down, select one:
6. On **Type Extension** drop-down, select one.
7. Click **Save**.

## Create Custom Commands

### WebUI Procedure

1. Go to *Managed Devices :: Devices :: <device name> :: Commands*.

2. Click **Add** (displays dialog).

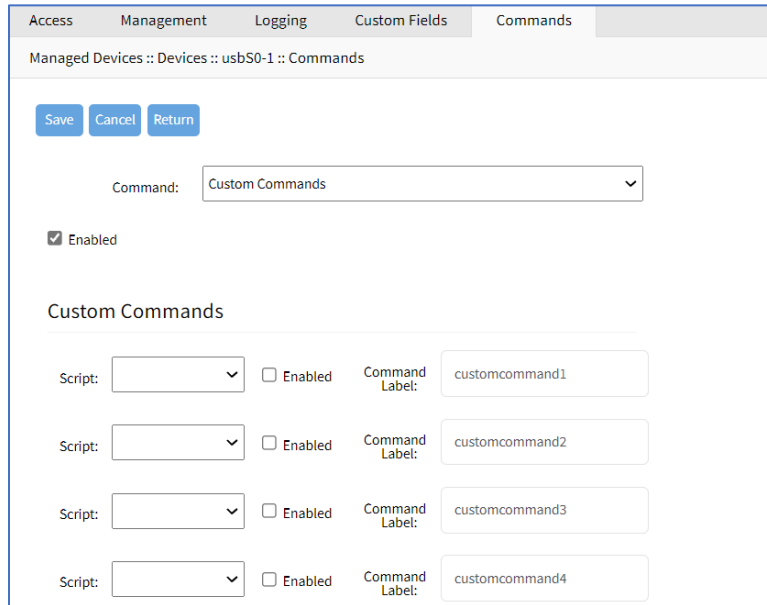

3. In **Command** drop-down, select **Custom Commands**.
4. Select **Enable** checkbox.
5. In *Custom Commands* menu  
 On **Script** drop-down, select one.  
 Next to drop-down, select **Enabled** checkbox.  
 Adjust **Command Label** to match the command option in the script.
6. As needed, repeat for additional Scripts.
7. Click **Save**.

**CLI Procedure**

1. Go to /settings/devices/<device name>/commands
2. Use the add command to create a new custom field.
3. Use the set command to define a field\_name and field\_value.
4. Save the changes with commit

```
[admin@nodegrid /]# /settings/devices/Serial_Console/commands/
[admin@nodegrid /]#add
[+admin@nodegrid commands]#set command=custom_commands
[+admin@nodegrid commands]#set custom_command_enabled1=yes
[+admin@nodegrid commands]#set custom_command_script1=SSH.py
[+admin@nodegrid commands]#set custom_command_label1=SSH
[+admin@nodegrid commands]#commit
```

## Views tab

On this page, an admin can create and manage a device-based tree structure. This can be configured for specific organizational or physical structure layouts. Groups may also be used to aggregate monitoring values like a rack or room level.

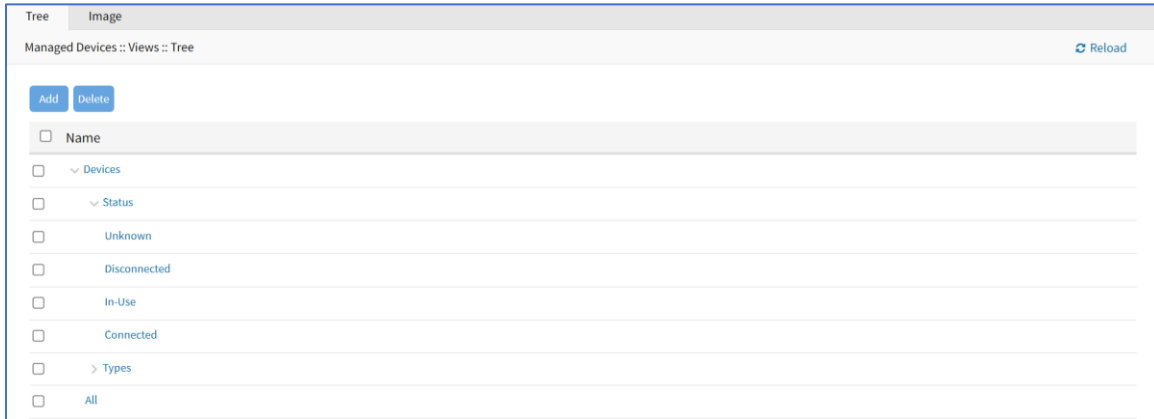

### Tree sub-tab

This displays the tree structure. On first opening, the roots are shown: Devices, Appliances, Groups.



### View Tree Branches

#### WebUI Procedure

1. Click the right  icon to display the next branch level.
2. If further branch levels are available, click the right  icon to expand the branch.
3. To contract the branch, click the down  icon.

### Add a Branch Item

#### WebUI Procedure

1. Go to *Managed Devices :: Views :: Tree*.
2. Click **Add** (displays dialog).



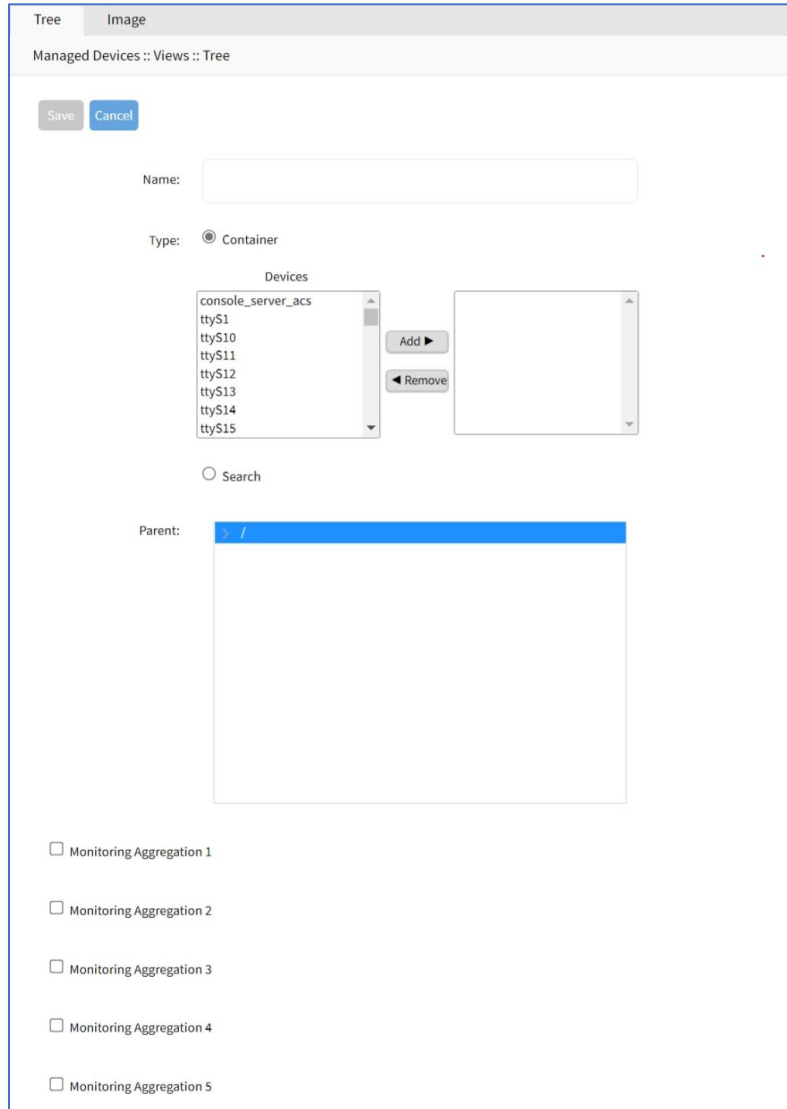

3. Enter a **Name**.
4. To include in *Contains*, in *Devices* panel:  
 Select from left-side panel, click **Add**► to move to right-side panel.  
 To remove from right-side panel, select, and click **◀Remove**.
5. To search for an item, select **Search** radio button. Opens a search dialog to locate and select.

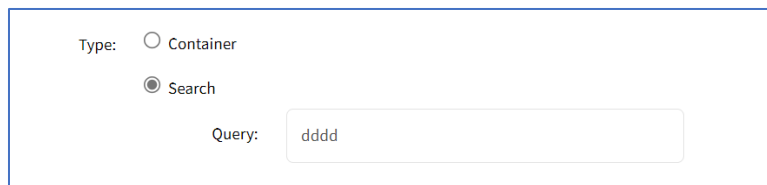

6. To select a **Parent**, click on the solid bar, expand the tree to locate the parent for this addition.

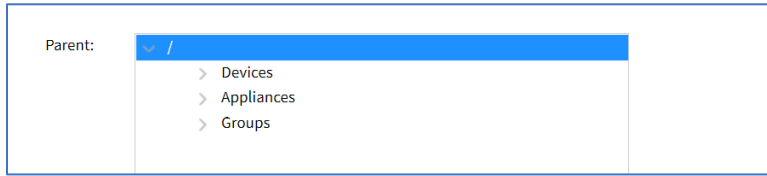

7. As needed, select **Monitoring Aggregation** checkbox.

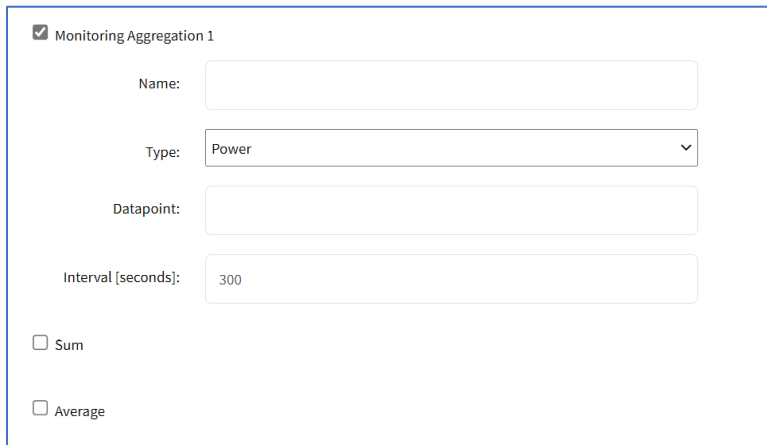

Enter **Name**

On **Type** drop-down, select one (**Power, Apparent Power, Power Factor, Current, Voltage, Frequency, Temperature, Humidity, Fan Speed, Time Left, Counter, Percent**).

Enter **Datapoint**.

Enter **Interval (seconds)**.

Select **Sum** checkbox or **Average** checkbox.

8. (as needed) Repeat for other **Aggregations**.

9. When done, click **Save**.

## Delete a Branch Item

### WebUI Procedure

1. Go to *Managed Devices :: Views :: Tree*.
2. Click **Delete** (displays confirmation dialog).

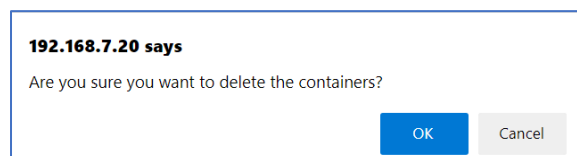

3. Click **OK**.

### Image sub-tab

Available images are shown on this page.

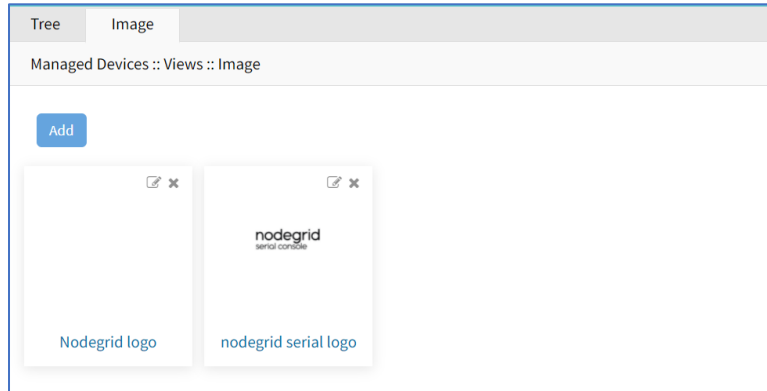

## Add Image

### WebUI Procedure

1. Go to *Managed Devices :: Views :: Image*.
2. Click **Add** (displays dialog).

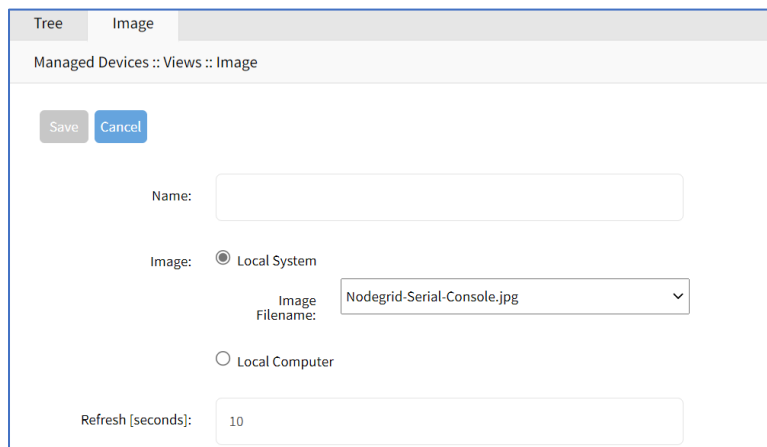

3. Enter **Name**.
4. In *Image* menu:  
 Select **Local System** radio button, then select from the **Image Filename** drop-down.  
 Select **Local Computer** radio button.

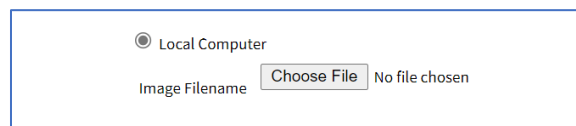

Click **Choose File**, then locate and select the graphic file.

5. Click **Save**.

## Add Image Property Details

### WebUI Procedure

1. Go to *Managed Devices :: Views :: Image*.

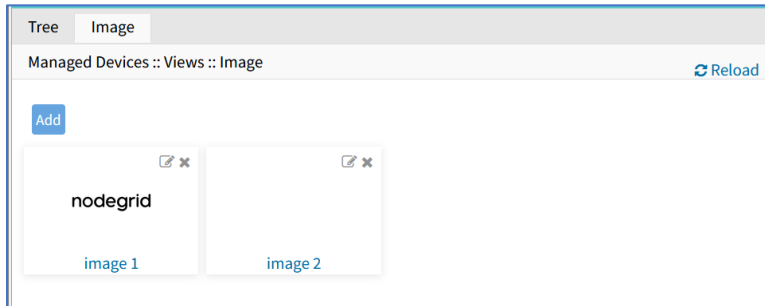

2. Click on an image to display.
3. Right-click on the image (displays properties dialog).

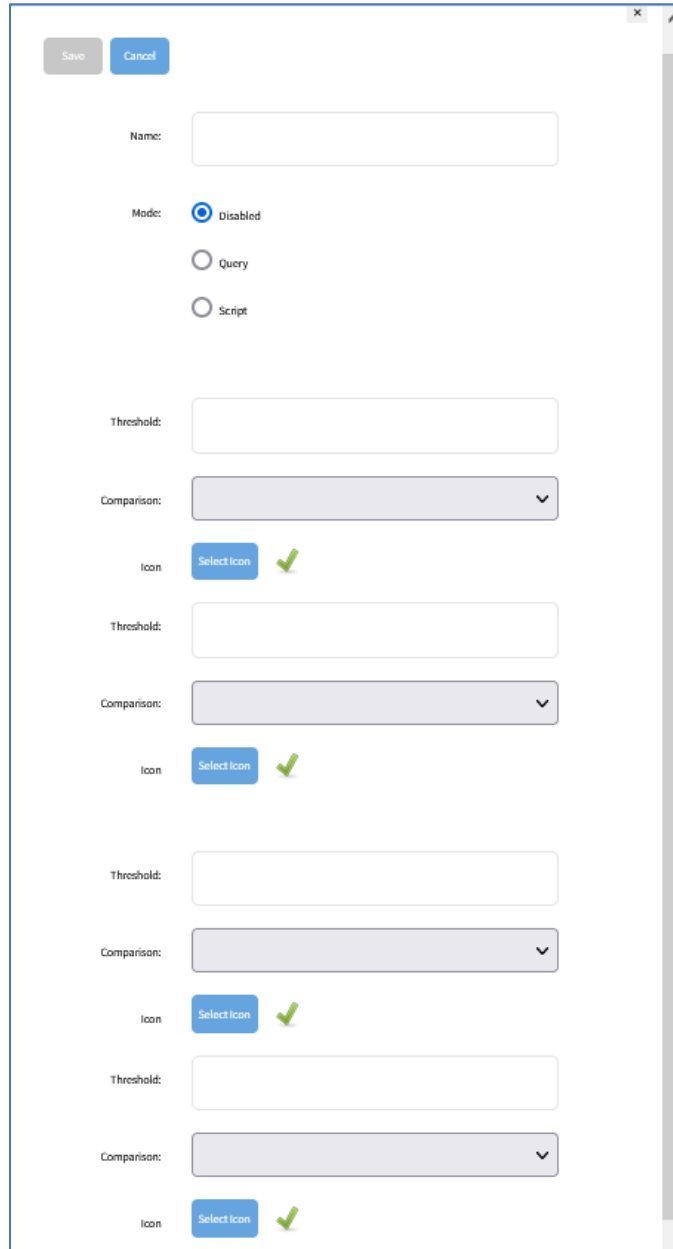

The screenshot shows a configuration window with a 'Save' button and a 'Cancel' button. It contains four identical sections. Each section has a 'Name' text input field, a 'Mode' section with three radio buttons ('Disabled' is selected), a 'Threshold' text input field, a 'Comparison' dropdown menu, and an 'Icon' section with a 'Select Icon' button and a green checkmark.

- 4. Enter **Name**.
- 5. In *Mode* menu, select one:

**Disabled** radio button:

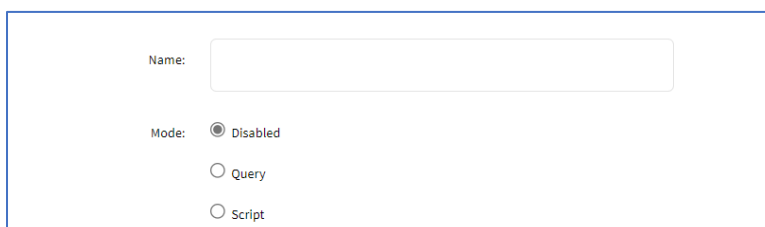

This close-up shows the 'Name' text input field and the 'Mode' section with three radio buttons: 'Disabled' (selected), 'Query', and 'Script'.

**Query** radio button:

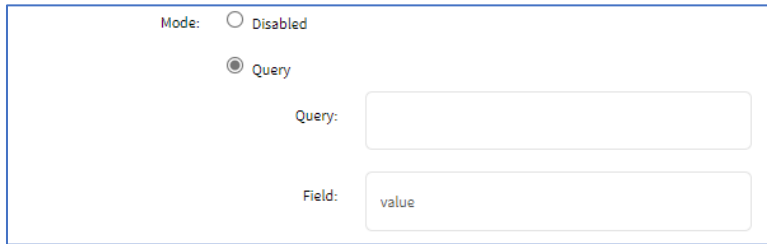

Enter **Query**

Enter **Field**

**Script** radio button:

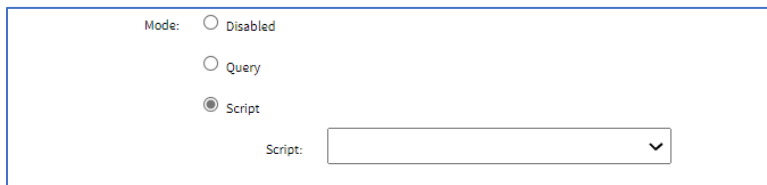

On **Script** drop-down, select one.

6. In *Threshold* menu:

Enter a **Threshold** value

On the **Comparison** drop-down select one

Click **Icon** and select from the dialog



(as needed) Enter details for another Threshold (up to 4).

7. Click **Save**.

## Types tab

Administrators can manage Device Type settings for customized versions of existing device types. There are situations when the device type default value does not match with customer's default values. The admin can clone, edit, or delete existing device types. Settings can be adjusted as needed. When saved, new settings are immediately effective for all devices with that device type.

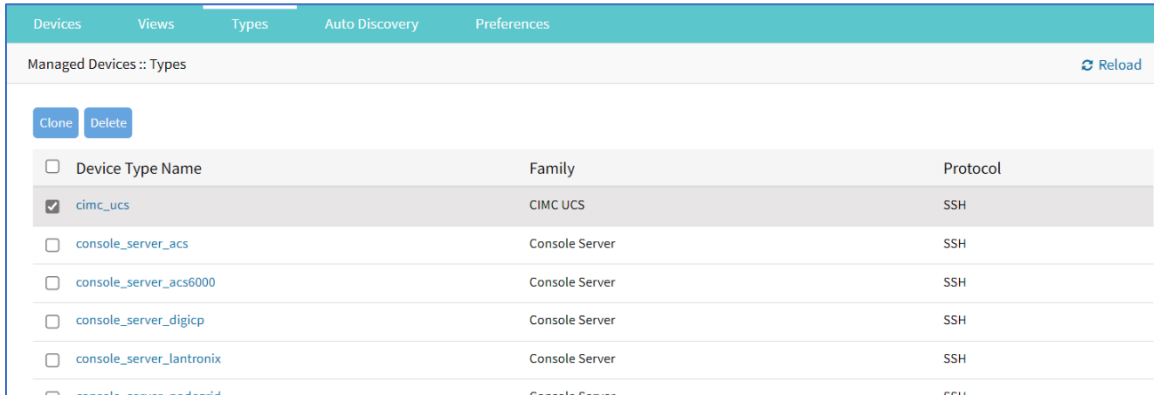

## Manage Types

### Clone a Type

#### WebUI Procedure

1. Go to *Managed Devices :: Types*.
2. Locate and select the checkbox of the type to be cloned.
3. Click **Clone** (displays dialog)

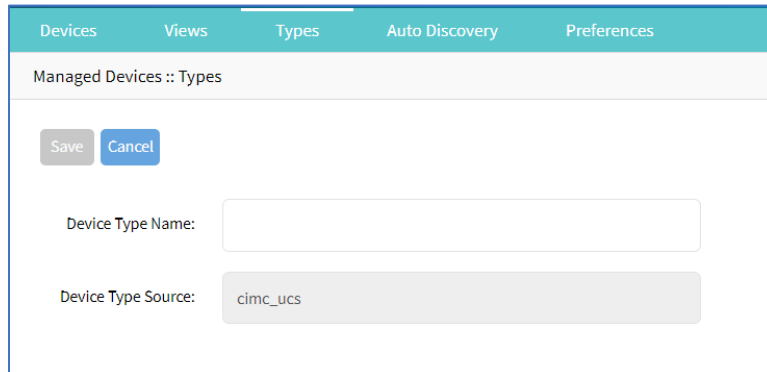

4. Enter **Device Type Name**.
5. Click **Save**.

### Clone Validation

Ensure the source device is correctly configured. After the clone is created, use this verification process:

1. Access the clone to verify username, password and IP address is correct.
2. Audit the log files to verify data logging and event logging settings are correct.
3. Simulate events and check if any notification is created.
4. Verify events are detected on the data and event logs.
5. Verify that the device is in the correct authorization group with proper access rights.

## Edit a Device Type

### WebUI Procedure

1. Go to *Managed Devices :: Types*.
2. In the *Device Type Name* column, locate and click on the name.

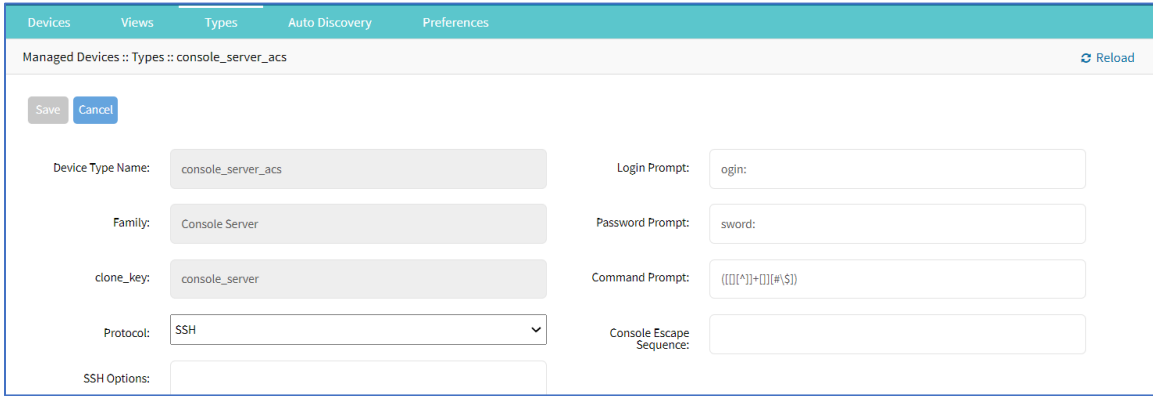

3. Modify details as needed:
4. Click **Save**.

## Delete a Type

### WebUI Procedure

1. Go to *Managed Devices :: Types*.
2. Locate and select the checkbox to be deleted.
3. Click **Delete** (displays confirmation dialog).

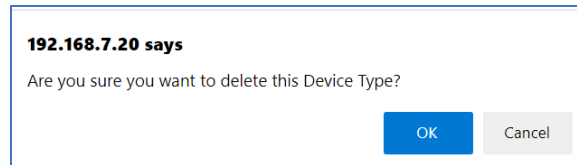

4. Click **OK**.

## Auto Discovery tab

The System automatically discovers and adds network devices, enabled ports on console servers, KVM switches, and VMware (virtual serial ports and virtual machines).

### Auto Discovery Configuration Process

#### Auto Discovery Process

This is the process to configure auto discovery on various devices.

1. Create a template device. (For each device type, a template device must be created.)



Clone is recommended. The template needs to include all the settings as for an end device, except connection details to the discovered devices.

2. For network devices, create a Network Scan.
3. For virtual machines, create a Virtual Manager.
4. For all devices, create a Discovery Rule.

Discovery rules must be associated with the template device. These rules determine action taken on every discovered device.

5. Start the discovery process.

This process automatically starts when a device is added to the Nodegrid Platform. A manual discovery process can be started from the WebUI (*Managed Devices :: Auto Discovery :: Discover Now*) or CLI (`/settings/auto_discovery/discover_now/`).

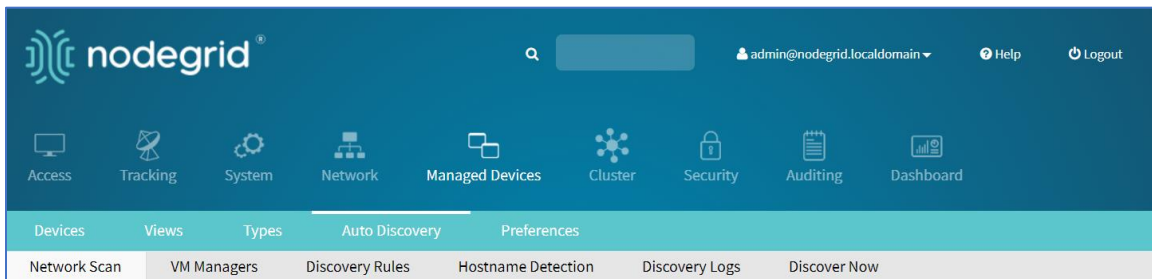

## Auto Discovery Configurations

### Auto Discovery: Configure Console Server

The Console Server appliances can be discovered using the Network Devices process. Use the Auto Discovery process to automatically add and configure managed devices for third-party console server ports and KVM switch ports.

#### Step 1 – Create a Template Device

The template device must be created first. In this process, only enter the details listed.

##### WebUI Procedure

1. Go to *Managed Devices :: Devices*.
2. Click **Add** (displays dialog).
3. Enter **Name** (of the template).
4. In the **Type** drop-down, select one (console\_server\_acs, console\_server\_acs6000, console\_server\_lantronix, console\_server\_opengear, console\_server\_digicp, console\_server\_raritan, console\_server\_perle).
5. For **IP Address**, enter **127.0.0.1**
6. Select **Ask During Login** checkbox.
7. In *End Point* menu, select one

**Serial Port** radio button.

**KVM Port** radio button.

Enter **Port Number**.

8. On **Mode** drop-down, select **Disabled** (ensures the device is not displayed on the Access page).
9. Click **Save**.

### CLI Procedure

1. Go to /settings/devices
2. Use the add command to create a new device.
3. Use the set command to define the following settings:

name

type (console\_server\_acs, console\_server\_acs6000, console\_server\_lantronix,  
console\_server\_opengear, console\_server\_digicp, console\_server\_raritan, console\_server\_perle)

ip\_address as 127.0.0.1

Set credential to Ask During Login

endpoint (serial\_port or kvm\_port)

port\_number (port number)

Set mode to disabled

4. Save the changes with commit.

```
[admin@nodegrid /]# cd /settings/devices
[admin@nodegrid devices]# add
[admin@nodegrid {devices}]# set name=Console_Server_Port_Template
[admin@nodegrid {devices}]# set type=console_server_acs6000
[admin@nodegrid {devices}]# set ip_address=127.0.0.1
[admin@nodegrid {devices}]# set end_point=serial_port
[admin@nodegrid {devices}]# set port_number=1
[admin@nodegrid {devices}]# set credential=ask_during_login
[admin@nodegrid {devices}]# set mode=disabled
[admin@nodegrid {devices}]# commit
```

### Step 2 – Create a Discovery Rule

#### WebUI Procedure

1. Go to *Managed Devices :: Auto Discovery :: Discovery Rules*.
2. Click **Add** (displays dialog).

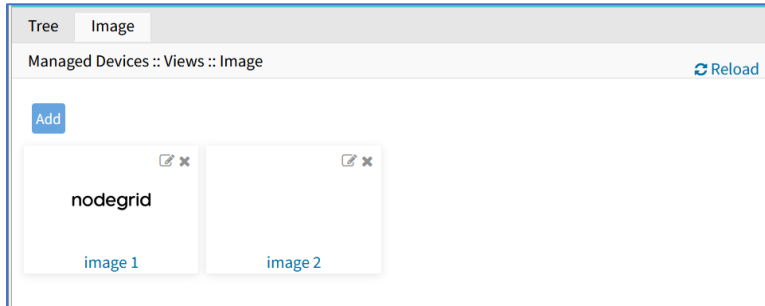

3. Enter **Rule Name**.
4. On **Status** drop-down, select one (**Enabled, Disabled**).
5. In *Discovery Method* menu, select one:  
**Console Server Ports** radio button. Enter **Port List** (list of ports to scan (i.e., 1,3,5,10-20)).

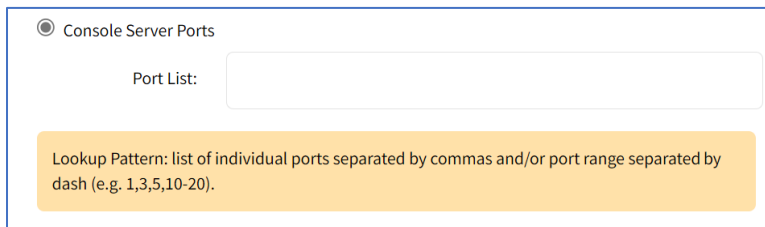

**KVM Ports** radio button. Enter **Port List** (list of ports to scan (i.e., 1,3,5,10-20)).

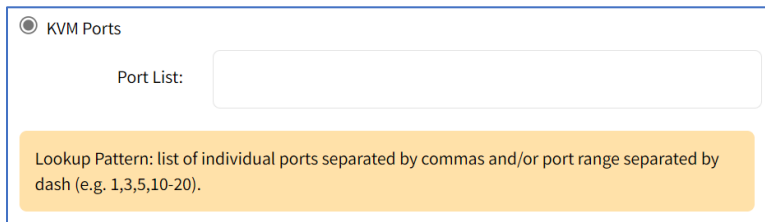

6. (optional) In *Host or VM Identifier* menu, enter parameter to further filter (if provided, part of port name must match value).
7. On **Action** drop-down, select what to do when a new device is discovered (**Clone (Mode: Enabled), Clone (Mode: On-Demand), Clone (Mode: Discovered), Discard Discovered Devices**).
8. In the **Clone from** drop-down, select the template device (created earlier).
9. Click **Save**.

After the appliance is created, the Nodegrid Platform automatically starts discovering attached devices (based on the created Discovery Rules).

*This process takes several minutes.*



### CLI Procedure

1. Go to `/settings/auto_discovery/discovery_rules/`
2. Use the add command to create a Discovery Rule.
3. Use the set command to define the following settings:
  - rule\_name (for the Discovery Rule)
  - status for the rule (enabled, disabled)
  - method set to `console_server_ports` or `kvm_ports`
  - port\_list (list of ports which should be scanned – i.e., 1,3,5,10-20)
  - host\_identifier parameter (apply as a filter)
    - (If a value is provided, part of the port name must match the value.)
4. For action (enter action taken when a new device is discovered) (`clone_mode_enabled`, `clone_mode_on-demand`, `clone_mode_discovered`, `discard_device`).
5. `clone_from` (template device created earlier).
6. Save the changes with `commit`.

```
[admin@nodegrid /]# cd /settings/auto_discovery/discovery_rules/
[admin@nodegrid discovery_rules]# add
[admin@nodegrid {discovery_rules}]# set rule_name=Console_Server_Ports
[admin@nodegrid {discovery_rules}]# set status=enabled
[admin@nodegrid {discovery_rules}]# set method=console_server_ports
[admin@nodegrid {discovery_rules}]# set port_list=1-48
[admin@nodegrid {discovery_rules}]# set action=clone_mode_enabled
[admin@nodegrid {discovery_rules}]# set clone_from=Console_Server_Ports_Template
[admin@nodegrid {discovery_rules}]# commit
```

After the appliance was created, the Nodegrid Platform automatically starts discovery of attached devices based on the created Discovery Rules.

*This process takes several minutes.*

## Auto Discovery: Configure Network Devices

Network appliances can be automatically discovered and added to the Nodegrid Platform. This includes appliances which support Telnet, SSH, ICMP, Console Servers, KVM Switches or IMPI protocols plus others.

Appliances can be discovered through various methods, in combination or singly:

- Similar Devices (select one of the devices from the drop-down),
- Port Scan and enter a list of ports in the Port List field,
- Ping
- DHCP (via MAC Address)

Setup is a three-step process.

### Step 1 – Create a Template Device

The device must be created first. In this process, only enter the details listed.

#### WebUI Procedure

1. Go to *Managed Devices :: Devices*.
2. Click **Add** (displays dialog).
3. Enter **Name** (of the template).
4. In the **Type** drop-down, select one (device\_console, ilo, imm, drac, idrac6, ipmi1.5, impi2.0, ilom, cimc\_ucs, netapp, infrabox, pdu).
5. For **IP Address**, enter **127.0.0.1**
6. Enter **Username**
7. Enter **Password** and **Confirm Password**.  
Alternatively, select **Ask During Login** checkbox (user credentials are entered during login).
8. On **Mode** drop-down, select **Disabled** (ensures the device is not displayed on the Access page).
9. Click **Save**.

#### CLI Procedure

1. Go to /settings/devices
2. Use the add command to create a new device.
3. Use the set command to define the following settings:

name

type (device\_console, ilo, imm, drac, idrac6, ipmi1.5, impi2.0, ilom, cimc\_ucs, netapp, infrabox, pdu\*)

ip\_address as 127.0.0.1

username and password (of the device)  
or set credential ask\_during\_login

set mode to disabled

4. Save the changes with commit.

```
[admin@nodegrid /]# cd /settings/devices
[admin@nodegrid devices]# add
[admin@nodegrid {devices}]# set name=Network_Template
[admin@nodegrid {devices}]# set type=device_console
[admin@nodegrid {devices}]# set ip_address=127.0.0.1
[admin@nodegrid {devices}]# set credential=ask_during_login

or

[admin@nodegrid {devices}]# set credential=set_now
[admin@nodegrid {devices}]# set username=admin password=admin

[admin@nodegrid {devices}]# set mode=disabled
[admin@nodegrid {devices}]# commit
```

## Step 2 – Create a Network Scan

### WebUI Procedure

1. Go to *Managed Devices :: Auto Discovery :: Network Scan*.
2. Click **Add** (displays dialog).

Network Scan | VM Managers | Discovery Rules | Hostname Detection | Di

Managed Devices :: Auto Discovery :: Network Scan

Scan ID:

IP Range Start:

IP Range End:

Enable Scanning

Similar Devices

Device:

Port Scan

Port List:

List of individual ports separated by commas and/or port range separated by dash (e.g. 1,3,5,10-20).

Ping

Scan Interval (in minutes):

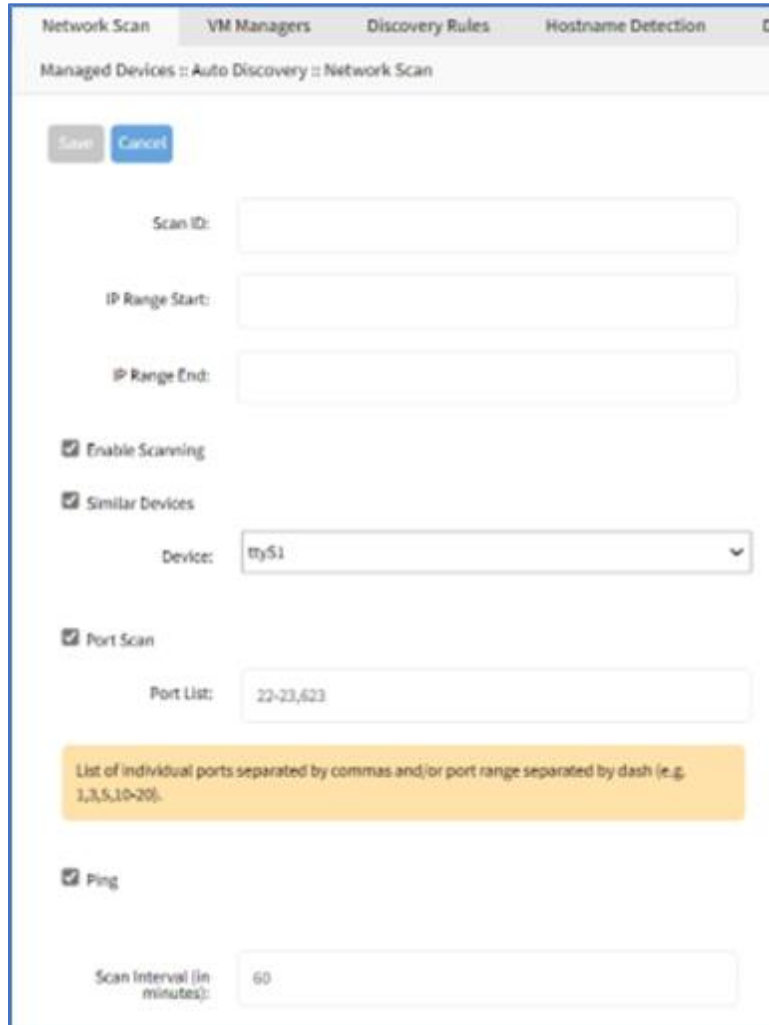

3. Enter **Name** (of Scan ID).
4. Enter **IP Range Start**.
5. Enter **IP Range End**.
6. Select **Similar Devices** checkbox.  
On **Device** drop-down, select an existing template (to identify devices).
7. Select **Enable Scanning** checkbox.
8. Select **Port Scan** checkbox.  
Enter **Port List** (ports to be scanned, i.e., “2”, “3,104”, 11-20).
9. Select **Ping** checkbox (enables Ping function).
10. In **Scan interval (in minutes)**, enter a value.
11. Click **Save**.

**CLI Procedure**



1. Go to `/settings/auto_discovery/network_scan/`
2. Use the add command to create a Network Scan.
3. Use the set command to define the following settings:
  - scan\_id (name for the Network Scan)
  - ip\_range\_start and ip\_range\_end (define a network range to be scanned)
  - Set enable\_scanning to yes to enable the scan
4. Define one or more of the three scan methods:
  - similar\_devices (set device to match one of the existing devices or templates)
  - port\_scan (set to yes)
  - set port\_list (to a list of ports reachable on the device)
  - ping (no further settings are required)
5. Set scan\_interval (when to scan, in minutes).
6. Save the changes with commit.

```
[admin@nodegrid /]# cd /settings/auto_discovery/network_scan/
[admin@nodegrid network_scan]# add
[+admin@nodegrid {network_scan}]# set scan_id=SSH_Console
[+admin@nodegrid {network_scan}]# set ip_range_start=192.168.10.1
[+admin@nodegrid {network_scan}]# set ip_range_end=192.168.10.254
[+admin@nodegrid {network_scan}]# set enable_scanning=yes
[+admin@nodegrid {network_scan}]# set similar_devices=yes
[+admin@nodegrid {network_scan}]# set device= network_template
[+admin@nodegrid {network_scan}]# set port_scan=yes
[+admin@nodegrid {network_scan}]# set port_list=22
[+admin@nodegrid {network_scan}]# set ping=no
[+admin@nodegrid {network_scan}]# set scan_interval=100
[+admin@nodegrid {network_scan}]# commit
```

### Step 3 – Create a Discovery Rule

#### WebUI Procedure

1. Go to *Managed Devices :: Auto Discovery :: Discovery Rules*.
2. Click **Add** (displays dialog).
3. Enter **Name** (of the Discovery Rule).
4. On **Status** drop-down, select (**Enabled, Disabled**).
5. In **Discovery Method** menu:
  - Select **Network Scan** checkbox.
6. On **Scan ID** drop-down, select the created **Network Scan ID**.

- (optional) In *Host or VM Identifier* menu, enter parameter to further filter (if provided, part of port name must match value).
- On **Action** drop-down, select what to do when a new device is discovered (**Clone (Mode: Enabled)**, **Clone (Mode: On-Demand)**, **Clone (Mode: Discovered)**, **Discard Discovered Devices**).
- In the **Clone from** drop-down, select the template device created earlier.
- Click **Save**.

The Nodegrid Platform automatically starts discovering devices, based on the created Discovery Rules.

*This process takes several minutes.*

### CLI Procedure

- Go to `/settings/auto_discovery/discovery_rules/`
- Use the add command to create a Discovery Rule.
- Use the set command to define the following settings:
  - `rule_name` for the Discovery Rule
  - status for the discovered rule (enabled, disabled)
  - method set to `network_scan`
  - `scan_id` select a Network Scan ID created earlier
  - `host_identifier` parameter to further filter, if provided - part of the port name must match the value)
- For action, select what should be done on a new device discovery (`clone_mode_enabled`, `clone_mode_on-demand`, `clone_mode_discovered`, `discard_device`).
- `clone_from` set to the template device created earlier.
- Save the changes with `commit`.

```
[admin@nodegrid /]# cd /settings/auto_discovery/discovery_rules/
[admin@nodegrid discovery_rules]# add
[admin@nodegrid {discovery_rules}]# set rule_name=Network_Scan
[admin@nodegrid {discovery_rules}]# set status=enabled
[admin@nodegrid {discovery_rules}]# set method=network_scan

[admin@nodegrid {discovery_rules}]# set scan_id=SSH_Console
[admin@nodegrid {discovery_rules}]# set action=clone_mode_enabled
[admin@nodegrid {discovery_rules}]# set clone_from=Network_Template
[admin@nodegrid {discovery_rules}]# commit
```

The Nodegrid Platform automatically starts discovering devices, based on the created Discovery Rules.

*This process takes several minutes.*

## Auto Discovery: Configure DHCP Clients

The Nodegrid Platform can be used as a DHCP Server for Clients within the management network. These devices can be automatically discovered and added to the Nodegrid platform. This feature only supports DHCP Clients that receive DHCP lease from the local Nodegrid Platform.

### Step 1 – Create a Template Device

#### WebUI Procedure

1. Go to *Managed Devices :: Devices*.
2. Click **Add** (displays dialog).
3. Enter **Name** (of the template).
4. For **IP Address**, enter **127.0.0.1**
5. In the **Type** drop-down field, select one (device\_console, ilo, imm, drac, idrac6, ipmi1.5, impi2.0, ilom, cimc\_ucs, netapp, infrabox, pdu\*).
6. Enter **Username**.
7. Enter **Password** and **Confirm Password**.  
Alternatively, select **Ask During Login** checkbox (user credentials are entered during login).
8. Select **Mode Disabled** checkbox (ensures device is not displayed on Access page).
9. Click **Save**.

#### CLI Procedure

1. Go to /settings/devices
2. Use the add command to create a new device,
3. Use the set command to define the following settings:
  - name
  - type (device\_console, ilo, imm, drac, idrac6, ipmi1.5, impi2.0, ilom, cimc\_ucs, netapp, infrabox, pdu\*)
  - ip\_address as 127.0.0.1
  - username and password (of the device)  
or set credential ask\_during\_login
  - Set mode to disabled
4. Save the changes with commit.

```
[admin@nodegrid /]# cd /settings/devices
[admin@nodegrid devices]# add
[admin@nodegrid {devices}]# set name=Network_Template
[admin@nodegrid {devices}]# set type=device_console
[admin@nodegrid {devices}]# set ip_address=127.0.0.1
```

```
[admin@nodegrid {devices}]# set credential=ask_during_login

or

[admin@nodegrid {devices}]# set credential=set_now
[admin@nodegrid {devices}]# set username=admin password=admin

[admin@nodegrid {devices}]# set mode=disabled
[admin@nodegrid {devices}]# commit
```

## Step 2 – Create a Discovery Rule

### WebUI Procedure

1. Go to *Managed Devices :: Auto Discovery :: Discovery Rules*
2. Click **Add** (displays dialog).
3. Enter **Name**.
4. On **Status** drop-down, select (**Enabled, Disabled**).
5. On *Discovery Method* menu:  
Select **DHCP** checkbox.
6. (optional) To filter specific entries, enter **MAC Address**.
7. (optional) In *Host or VM Identifier* menu, enter parameter to further filter (if provided, part of port name must match value).
8. On **Action** drop-down, select what to do when a new device is discovered (**Clone (Mode: Enabled), Clone (Mode: On-Demand), Clone (Mode: Discovered), Discard Discovered Devices**).
9. In the **Clone from** drop-down, select the template device created earlier
10. Click **Save**.

After the rule is created, the device is automatically added to the system as soon as it receives a DHCP address or renews its DHCP address lease. The default for the address lease renewal is every 10 minutes.

### CLI Procedure

1. Go to `/settings/auto_discovery/discovery_rules/`
2. Use the add command to create a Discovery Rule.
3. Use the set command to define the following settings:  
rule\_name for the Discovery Rule  
status for the discovered rule (enabled, disabled)  
method set to dhcp  
(optional) use the mac\_address field to filter to these specific entries

host\_identifier parameter can be used to further apply a filter if a value is provided then part of the port name has to match the value

action - select what should be performed when a new device is discovered (clone\_mode\_enabled, clone\_mode\_on-demand, clone\_mode\_discovered, discard\_device)

- clone\_from set to the template device created earlier.
- Save the changes with commit.

```
[admin@nodegrid /]# cd /settings/auto_discovery/discovery_rules/  
[admin@nodegrid discovery_rules]# add  
[admin@nodegrid {discovery_rules}]# set rule_name=Network_Scan  
[admin@nodegrid {discovery_rules}]# set status=enabled  
[admin@nodegrid {discovery_rules}]# set method=dhcp  
[admin@nodegrid {discovery_rules}]# set mac_address=00:0C:29  
[admin@nodegrid {discovery_rules}]# set action=clone_mode_enabled  
[admin@nodegrid {discovery_rules}]# set clone_from=Network_Template  
[admin@nodegrid {discovery_rules}]# commit
```

## Auto Discovery: Configure Virtual Machines

Virtual Machines which are managed by VMWare vCenter or run on ESXi can be discovered and managed directly on Nodegrid. The process will regularly scan vCenter or the ESXi host and detect newly added Virtual Machines. The virtual machines can be added as type virtual\_console\_vmware or virtual\_serial\_port.

**NOTE:** The free version of ESXi is not supported.

### Step 1 – Create a Template Device

The device must be created first. In this process, only enter the details listed.

#### WebUI Procedure

- Go to *Managed Devices :: Devices*.
- Click **Add** (displays dialog).
- Enter **Name** (of the template).
- In the **Type** drop-down, select one (virtual\_console\_vmware).
- For **IP Address**, enter **127.0.0.1**
- Enter **Username**.
- Enter **Password** and **Confirm Password**.

Alternatively, select **Ask During Login** checkbox (user credentials are entered during login).

- Select **Mode Disabled** checkbox (ensures device is not displayed on Access page).
- Click **Save**.

#### CLI Procedure

1. Go to /settings/devices
2. Use the add command to create a new device.
3. Use the set command to define the following settings:

```
name
type (virtual_console_vmware)
ip_address as 127.0.0.1
set mode to disabled
```

4. Save the changes with commit.

```
[admin@nodegrid /]# cd /settings/devices
[admin@nodegrid devices]# add
[admin@nodegrid {devices}]# set name=Virtual_Machine_Template
[admin@nodegrid {devices}]# set type=virtual_console_vmware
[admin@nodegrid {devices}]# set ip_address=192.168.2.151
[admin@nodegrid {devices}]# set mode=disabled
[admin@nodegrid {devices}]# commit
```

## Step 2 – Create a Discovery Rule

### WebUI Procedure

1. Go to *Managed Devices :: Auto Discovery :: Discovery Rules*.
2. Click **Add** (displays dialog).
3. Enter **Rule Name**.
4. On **Status** drop-down, select an item (**Enabled, Disabled**).
5. In *Discovery Method* menu, select **VM Manager**.

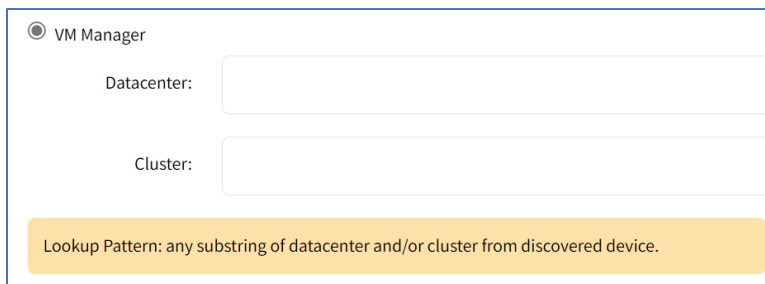

(optional) To filter the scan, enter **Datacenter** and **Cluster**.

6. (optional) In *Host or VM Identifier* menu, enter parameter to further filter (if provided, part of port name must match value).
7. On **Action** drop-down, select what to do when a new device is discovered (**Clone (Mode: Enabled), Clone (Mode: On-Demand), Clone (Mode: Discovered), Discard Discovered Devices**).

8. In the **Clone from** drop-down, select the template device (created earlier).
9. Click **Save**.

**CLI Procedure**

1. Go to /settings/auto\_discovery/discovery\_rules/
2. Use the add command to create a Discovery Rule.
3. Use the set command to define the following settings:  
 rule\_name for the Discovery Rule  
 status for the discovered rule (enabled, disabled)  
 method set to vm\_manager  
 Use datacenter and cluster to define filters based on Data Center and or Cluster  
 host\_identifier parameter (apply as a filter)  
 (If a value is provided, part of the port name must match the value.)
4. For action (enter action taken when a new device is discovered) (clone\_mode\_enabled, clone\_mode\_on-demand, clone\_mode\_discovered, discard\_device).
5. clone\_from (template device created earlier).
6. Save the changes with commit.

```
[admin@nodegrid /]# cd /settings/auto_discovery/discovery_rules/
[admin@nodegrid discovery_rules]# add
[admin@nodegrid {discovery_rules}]# set rule_name=Virtual_Machine
[admin@nodegrid {discovery_rules}]# set status=enabled
[admin@nodegrid {discovery_rules}]# set method=vm_manager
[admin@nodegrid {discovery_rules}]# set action=clone_mode_enabled
[admin@nodegrid {discovery_rules}]# set clone_from=Virtual_Machine_Template
[admin@nodegrid {discovery_rules}]# commit
```

**Step 3 – Define a VM Manager**

**WebUI Procedure**

1. Go to *Managed Devices :: Auto Discovery :: VM Managers*.
2. Click **Add** (displays dialog).
3. In **VM Server**, enter the vCenter/ESXi IP or FQDN.
4. Enter **Username**.
5. On **Virtualization Type** drop-down, select **VMware**.
6. Enter **Password** and **Confirm Password**.
7. Enter **HTML console port** (if needed).
8. Click **Save**.

The Nodegrid Platform connects to the vCenter or ESXi system.

This process takes several minutes.

#### **CLI Procedure**

1. Go to `/settings/auto_discovery/vm_managers/`
2. Use the add command to create a VM Manager.
3. Use the set command to define the following settings:
  - `vm_server` (vCenter/ESXi IP or FQDN)
  - Define username and password
  - Adjust the `html_console_port` (if needed)
4. Save the changes with `commit`.

```
[admin@nodegrid /]# cd /settings/auto_discovery/vm_managers/  
[admin@nodegrid vm_managers]# add  
[admin@nodegrid {vm_managers}]# set vm_server=vCenter  
[admin@nodegrid {vm_managers}]# set username=admin  
[admin@nodegrid {vm_managers}]# set password=password  
[admin@nodegrid {vm_managers}]# commit
```

The Nodegrid Platform connects to the vCenter or ESXi system.

This process takes several minutes.

#### **Step 4 – Enable Discover Virtual Machines**

##### **WebUI Procedure**

1. Click on the newly created and connected VM Manager.



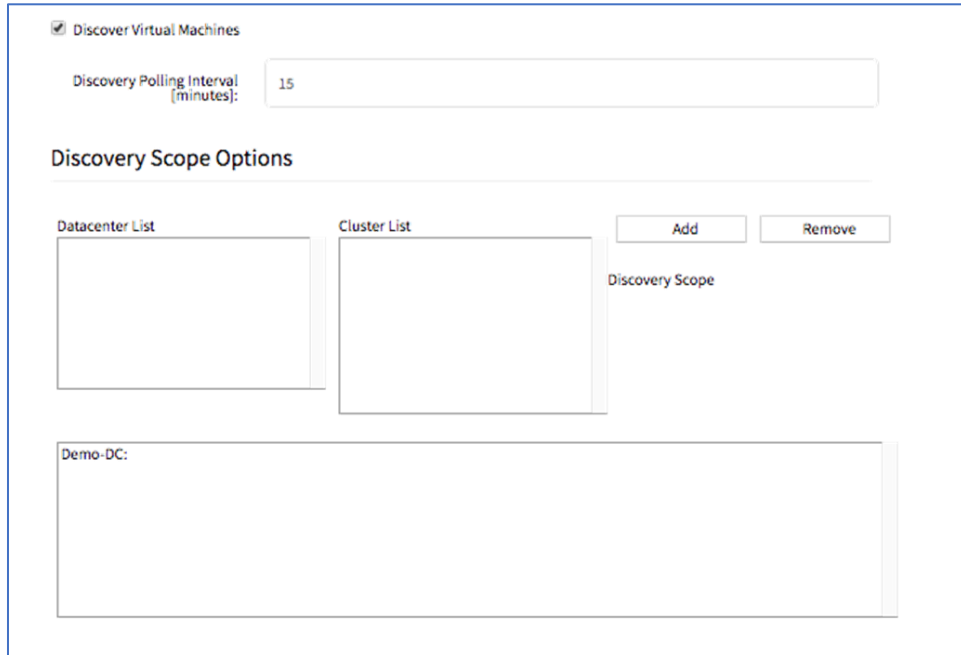

2. Select **Discover Virtual Machines** checkbox.
3. In **Discovery Polling Interval (minutes)**, enter a value.
4. Click **Save**.

**CLI Procedure**

1. Log into the newly created VM Manager
2. Enable Discover Virtual Machines option.
3. Define the Data Center and Discovery Polling Interval.
4. Save the changes with commit.

```
[admin@nodegrid 192.168.2.217]# set html_console_port=7331,7343
[admin@nodegrid 192.168.2.217]# set discover_virtual_machines=yes
[admin@nodegrid 192.168.2.217]# set interval_in_minutes=15
[admin@nodegrid 192.168.2.217]# set discovery_scope=Demo-DC!
[admin@nodegrid 192.168.2.217]# commit
```

**Network Scan sub-tab**

This lists available network scan setups.

Managed Devices :: Auto Discovery :: Network Scan							
<input type="checkbox"/>	Scan ID	IP Range	Status	Similar Devices	Port Scan	Ping	Interval
<input type="checkbox"/>	testtest	127.0.0.1/127.0.0.4	Enabled	tty51	22-23,623	Yes	60

## Add Network Scan

### WebUI Procedure

1. Go to *Managed Devices :: Auto Discovery :: Network Scan*.
2. Click **Add** (displays dialog).

Managed Devices :: Auto Discovery :: Network Scan	
Save	Cancel
Scan ID:	<input type="text"/>
IP Range Start:	<input type="text"/>
IP Range End:	<input type="text"/>
<input checked="" type="checkbox"/> Enable Scanning	
<input checked="" type="checkbox"/> Similar Devices	Device: <input type="text" value="tty51"/>
<input checked="" type="checkbox"/> Port Scan	Port List: <input type="text" value="22-23,623"/>
List of individual ports separated by commas and/or port range separated by dash (e.g. 1,3,5,10-20).	
<input checked="" type="checkbox"/> Ping	
Scan Interval (min):	<input type="text" value="60"/>

3. Enter **Name** (of Scan ID).
4. Enter **IP Range Start**.
5. Enter **IP Range End**.
6. Select **Enable Scanning** checkbox.

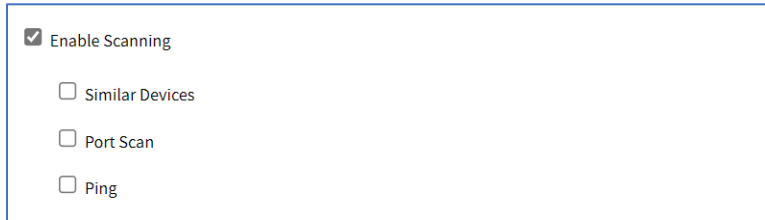

Enable Scanning  
 Similar Devices  
 Port Scan  
 Ping

Select **Similar Devices** checkbox (expands dialog)

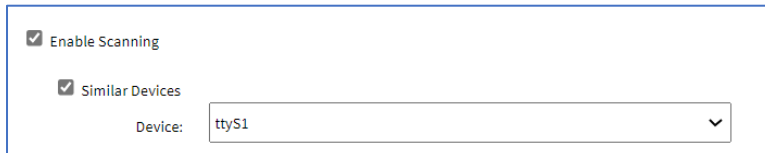

Enable Scanning  
 Similar Devices  
 Device:

On **Device** drop-down, select an existing template (to identify devices).

Select **Port Scan** checkbox (expands dialog)

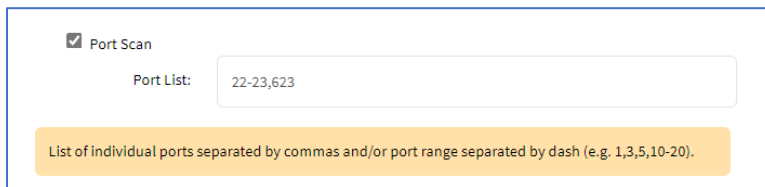

Port Scan  
 Port List:

List of individual ports separated by commas and/or port range separated by dash (e.g. 1,3,5,10-20).

Enter **Port List** (ports to be scanned, i.e., 2, 3, 11-20).

Select **Ping** checkbox (enables Ping function).

7. In **Scan interval (in minutes)**, enter a value.
8. Click **Save**.

## Edit Network Scan

### WebUI Procedure

1. Go to *Managed Devices :: Auto Discovery :: Network Scan*.
2. In *Scan ID* column, click on the name (displays dialog).
3. Make changes as needed.
4. Click **Save**.

## Delete Network Scan

### WebUI Procedure

1. Go to *Managed Devices :: Auto Discovery :: Network Scan*.
2. Select the checkbox(es) of items to delete.
3. Click **Delete** (displays confirmation dialog).

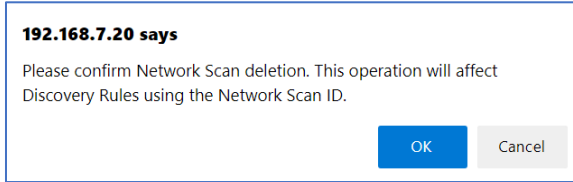

4. Click **OK**.

## VM Manager sub-tab

This lists VM Managers.

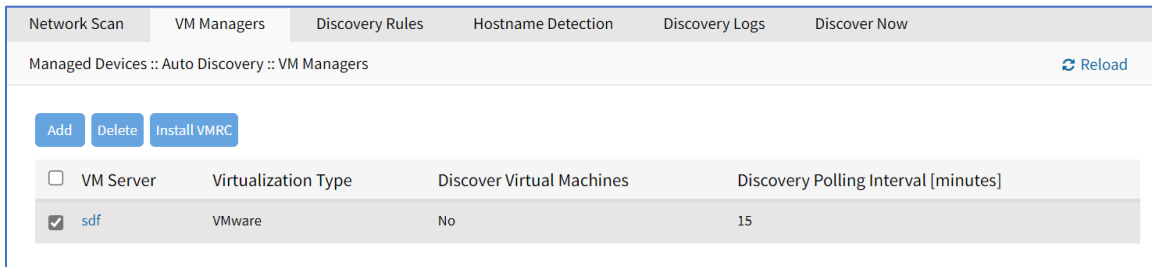

## Add VM Manager

### WebUI Procedure

1. Go to *Managed Devices :: Auto Discovery :: VM Managers*.
2. Click **Add** (displays dialog).

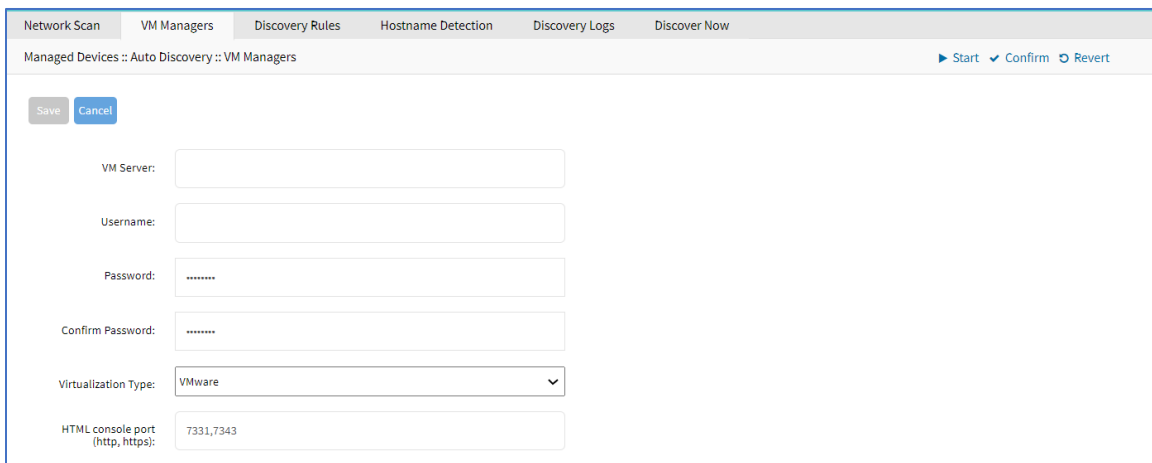

3. In **VM Server**, enter the *vCenter/ESXi IP* or **FQDN**.
4. Enter **Username**.
5. On **Virtualization Type** drop-down, select **VMware**.
6. Enter **Password** and **Confirm Password**.
7. Enter **HTML console port** (if needed).
8. Click **Save**.

## Delete VM Manager

### WebUI Procedure

1. Go to *Managed Devices :: Auto Discovery :: VM Managers*.
2. Select the checkbox(es) of items to delete.
3. Click **Delete** (displays confirmation dialog).

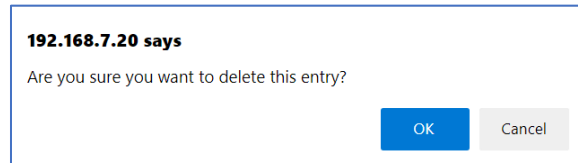

4. Click **OK**.

## Install VMRC

### WebUI Procedure

1. Go to *Managed Devices :: Auto Discovery :: VM Managers*.
2. Click **Install VMRC** (displays dialog).

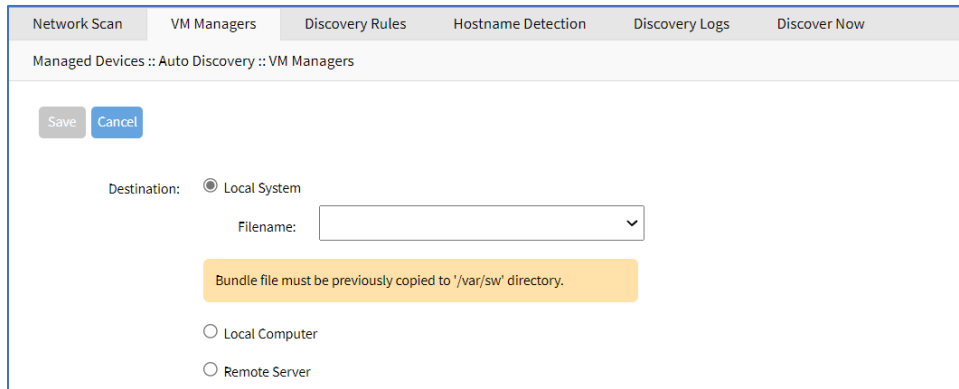

3. In *Destination* menu, select one:

**Local System** radio button . On **Filename**, select from drop-down

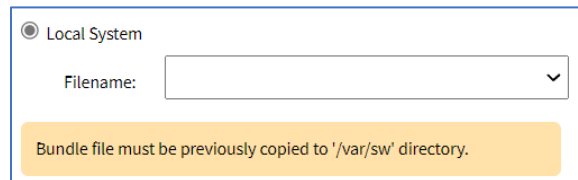

**Local Computer** radio button. On **File Name**, click **Choose File** (locate and select).

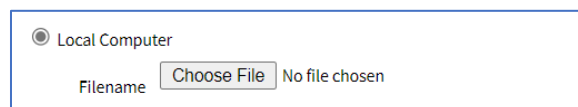

**Remote Server** radio button. Enter **URL**, **Username**, and **Password**.

(as needed) Select **Download path is absolute path name** checkbox.

Remote Server

URL:

Username:

Password:

Download path is absolute path name

4. Click **Save**.

### ***Discovery Rules sub-tab***

This lists all available discovery rules.

Network Scan	VM Managers	Discovery Rules	Hostname Detection	Discovery Logs	Discover Now			
Managed Devices :: Auto Discovery :: Discovery Rules					Reload			
<input type="button" value="Add"/> <input type="button" value="Delete"/> <input type="button" value="Up"/> <input type="button" value="Down"/>								
<input type="checkbox"/>	Order	Rule Name	Discovery Method	Host or VM Identifier	Lookup Pattern	Clone from	Action	Status
<input checked="" type="checkbox"/>	1.0	testest	DHCP			tty51	Clone (Mode: Enabled)	Enabled

### **Add Discovery Rule**

#### ***WebUI Procedure***

1. Go to *Managed Devices :: Auto Discovery :: Discovery Rules*.
2. Click **Add** (displays dialog).

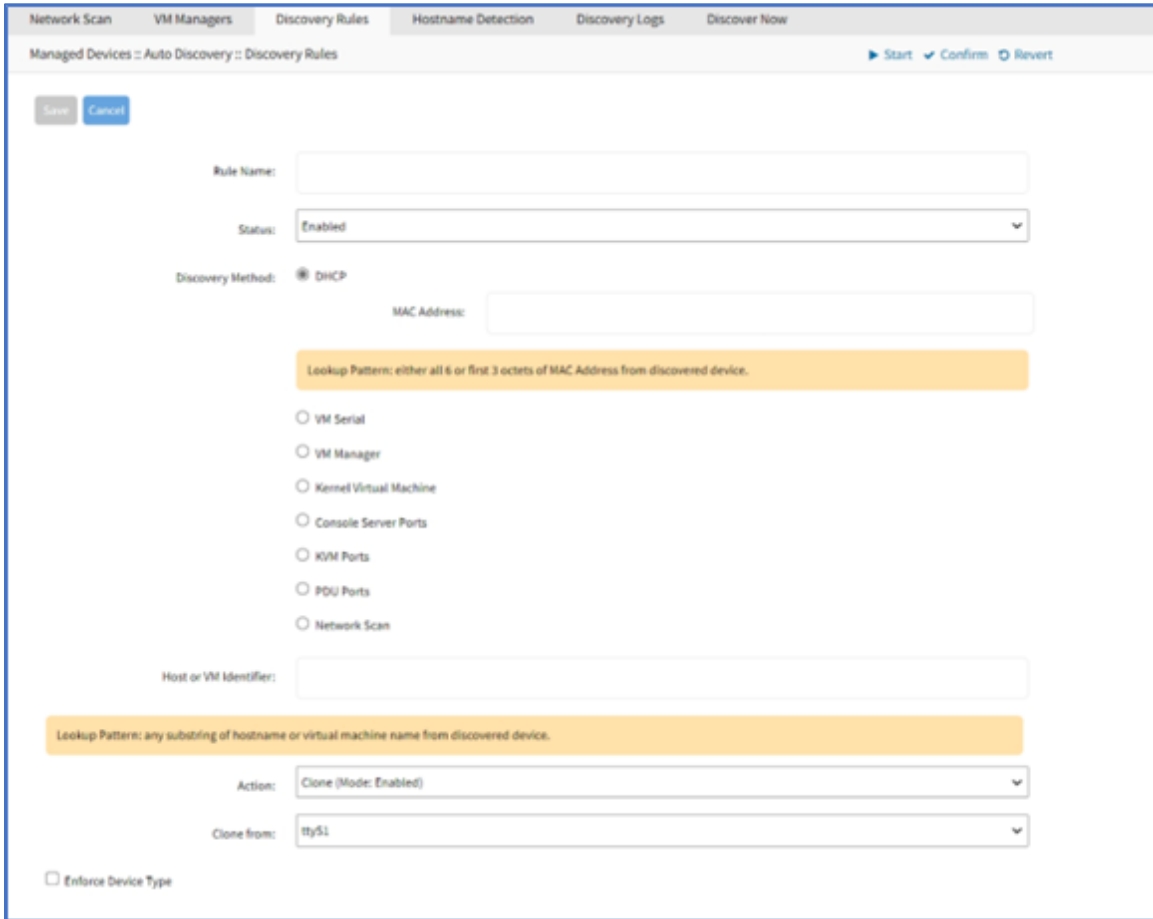

Network Scan VM Managers Discovery Rules Hostname Detection Discovery Logs Discover Now

Managed Devices :: Auto Discovery :: Discovery Rules ▶ Start ✓ Confirm ⌂ Revert

Rule Name:

Status:

Discovery Method:  DHCP

MAC Address:

Lookup Pattern: either all 6 or first 3 octets of MAC Address from discovered device.

VM Serial

VM Manager

Kernel Virtual Machine

Console Server Ports

KVM Ports

PDU Ports

Network Scan

Host or VM Identifier:

Lookup Pattern: any substring of hostname or virtual machine name from discovered device.

Action:

Clone from:

Enforce Device Type

3. Enter **Rule Name**.
4. On **Status** drop-down, select (**Enabled, Disabled**).
5. In *Discovery Method* menu, select one and enter associated details.  
**DHCP** radio button (expands dialog).

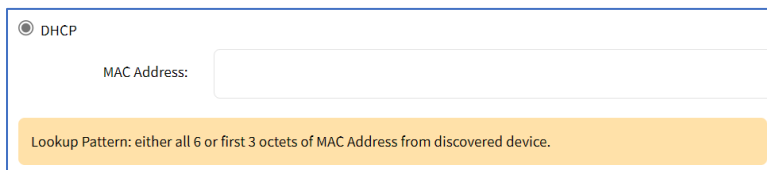

DHCP

MAC Address:

Lookup Pattern: either all 6 or first 3 octets of MAC Address from discovered device.

Enter **MAC Address**.

**VM Serial** radio button (expands dialog).

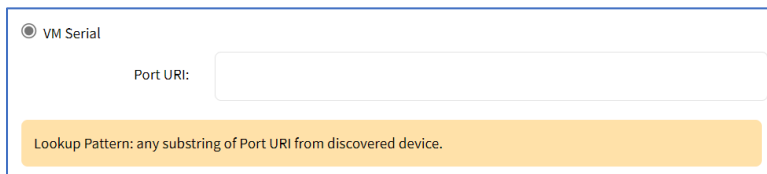

VM Serial

Port URI:

Lookup Pattern: any substring of Port URI from discovered device.

Enter **Port URL**.

**VM Manager** radio button (expands dialog).

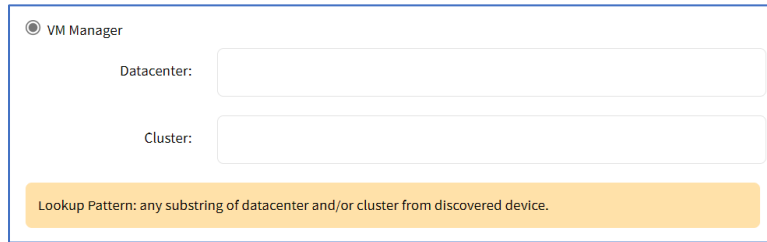

The screenshot shows a dialog box with a radio button selected for "VM Manager". Below the radio button are two text input fields: "Datacenter:" and "Cluster:". At the bottom of the dialog, there is a yellow box containing the text: "Lookup Pattern: any substring of datacenter and/or cluster from discovered device."

Enter **Description**.

Enter **Cluster**.

**Kernel Virtual Machine** radio button.

**Console Server Ports** radio button (expands dialog).

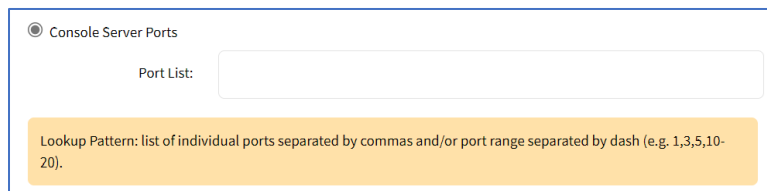

The screenshot shows a dialog box with a radio button selected for "Console Server Ports". Below the radio button is a text input field labeled "Port List:". At the bottom of the dialog, there is a yellow box containing the text: "Lookup Pattern: list of individual ports separated by commas and/or port range separated by dash (e.g. 1,3,5,10-20)."

Enter **Port List**.

**KVM Ports** radio button (expands dialog).

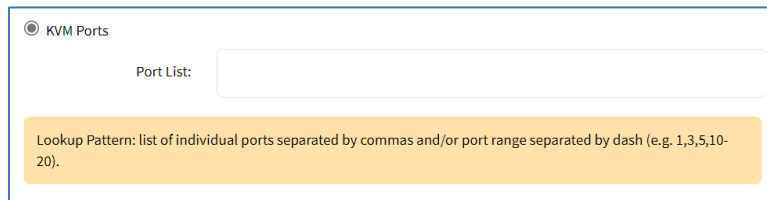

The screenshot shows a dialog box with a radio button selected for "KVM Ports". Below the radio button is a text input field labeled "Port List:". At the bottom of the dialog, there is a yellow box containing the text: "Lookup Pattern: list of individual ports separated by commas and/or port range separated by dash (e.g. 1,3,5,10-20)."

Enter **Port List**.

**PDU Ports** radio button (expands dialog).

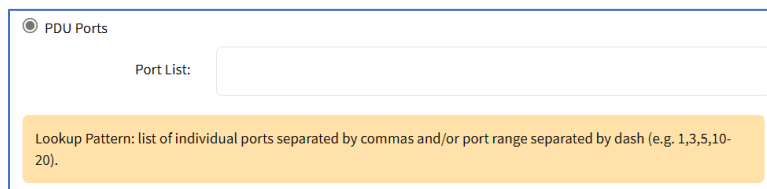

The screenshot shows a dialog box with a radio button selected for "PDU Ports". Below the radio button is a text input field labeled "Port List:". At the bottom of the dialog, there is a yellow box containing the text: "Lookup Pattern: list of individual ports separated by commas and/or port range separated by dash (e.g. 1,3,5,10-20)."

Enter **Port List**.

**Network Scan** radio button (expands dialog).



The screenshot shows a dialog box with a radio button selected for "Network Scan". Below the radio button is a text input field labeled "Scan ID:" with a dropdown arrow on the right side.

Enter **Scan ID**.



6. (optional) In *Host or VM Identifier* menu, enter parameter to further filter (if provided, part of port name must match value).
7. On **Action** drop-down, select what to do when a new device is discovered (**Clone (Mode: Enabled)**, **Clone (Mode: On-Demand)**, **Clone (Mode: Discovered)**, **Discard Discovered Devices**).
8. On **Clone from** drop-down, select appropriate template device.
9. Select **Enforce Device Type** checkbox.
10. Click **Save**.

## Edit Discovery Rule

### WebUI Procedure

1. Go to *Managed Devices :: Auto Discovery :: Discovery Rules*.
2. In the *Order* column, click on the name (displays dialog).
3. Make changes as needed.
4. Click **Save**.

## Delete Discovery Rule

### WebUI Procedure

1. Go to *Managed Devices :: Auto Discovery :: Discovery Rules*.
2. Select the checkbox(es) of items to delete.
3. Click **Delete** (displays confirmation dialog).

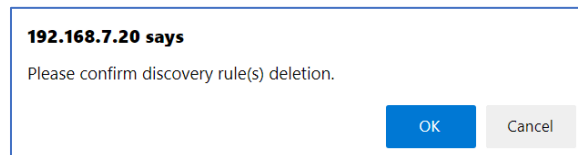

4. Click **OK**.

## Move Discovery Rule Priorities Up/Down

### WebUI Procedure

1. Go to *Managed Devices :: Auto Discovery :: Discovery Rules*.
2. Select the checkbox(es) of items.
3. Click **Up** or **Down** to move the sequence.

## Hostname Detection sub-tab

Hostname (network or serial) is automatically discovered when logged into the Nodegrid Platform, based on user access permissions. By default, Nodegrid devices include probes and matches for these device types: PDUs, NetApp, Console Servers, Device Consoles, and Service Processors.

Nodegrid sends a probe and waits for a match. If no match, a second probe is sent. This is repeated until a match occurs, then the probe process stops.

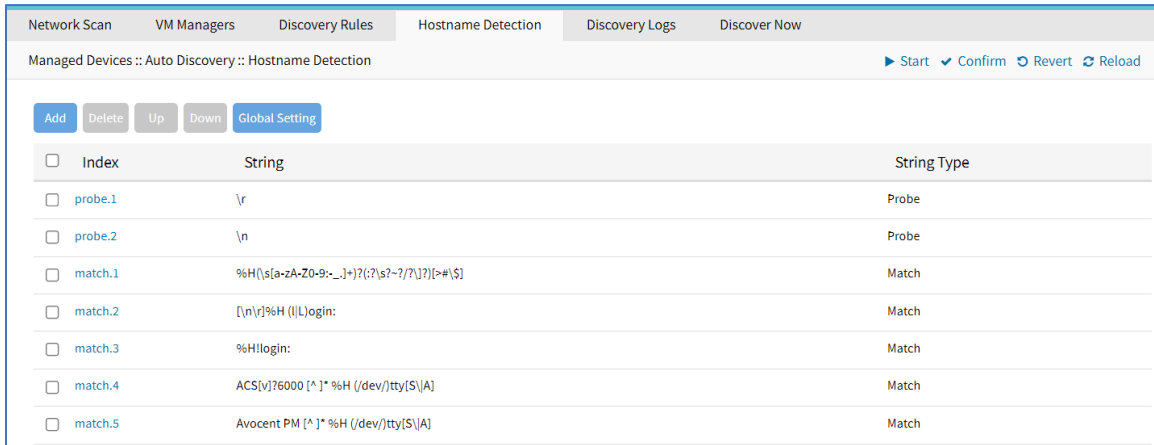

Index	String	String Type
probe.1	\r	Probe
probe.2	\n	Probe
match.1	%H([a-zA-Z0-9;:_+]?(:)?s?-/?)?[-#]\$,	Match
match.2	[(n v)%H ( L)login:	Match
match.3	%H!login:	Match
match.4	ACS[v]?6000 [^ ]* %H (/dev/tty[S A]	Match
match.5	Avocent PM [^ ]* %H (/dev/tty[S A]	Match

### Enable Hostname Detection

After hostname detection is enabled, it runs only once and then reverts to disabled.

#### WebUI Procedure

1. Go to *Managed Devices :: Devices*.
2. Click on the device **Name** (displays dialog).
3. On the Access sub-tab, scroll down to locate and select **Enable Hostname Detection** checkbox.



4. Click **Save**.

#### CLI Procedure

1. Go to `/settings/devices/<device name>/access`
2. Set `enable_hostname_detection` to `yes`
3. Save the changes with `commit`

```
[admin@nodegrid /]# /settings/devices/Device_Console_Serial/access/
[admin@nodegrid /]# set enable_hostname_detection=yes
[+admin@nodegrid /]# commit
```

### Create a Probe or Match

#### WebUI Procedure

1. Go to *Managed Devices :: Auto Discovery :: Hostname Detection*.
2. Click **Add** (displays dialog).

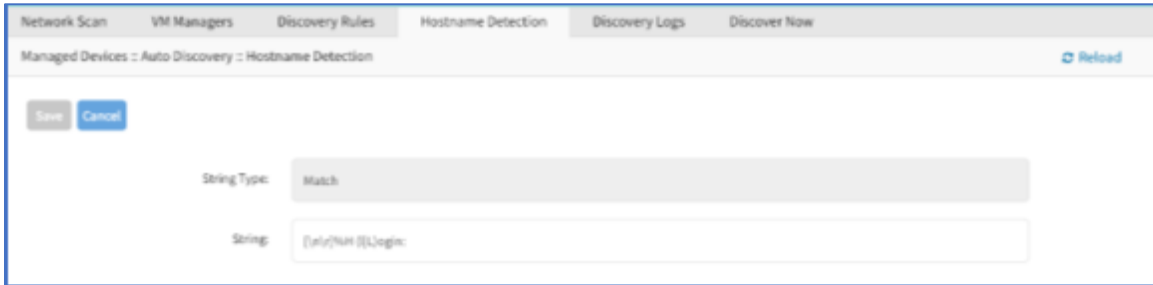

3. On **String Type** drop-down, select one (**Match**, **Probe**).

4. Enter **String** (characters for Match or Probe).

**NOTE:** For String Type: Matches, RegEx expressions are allowed. Use the variable %H to indicate the location of the hostname.

5. Click **Save**.

#### CLI Procedure

1. Go to `/settings/auto_discovery/hostname_detection/string_settings`

2. Type `add`

3. Use the `set` command to define `string_type` (match, probe)

4. Use the `set` command to define a probe or match string

5. Make active

6. Save the changes with `commit`

**NOTE:** For Matches RegEx expressions are allowed. Use the variable %H to indicate the location of the hostname

```
[admin@nodegrid /]# /settings/auto_discovery/hostname_detection/string_settings
[admin@nodegrid /]# add
[admin@nodegrid /]# set string_type=match
[+admin@nodegrid /]# set match_string=[\a\r]%H{I|L}ogin:
[+admin@nodegrid /]# active
[+admin@nodegrid /]# commit
```

### Delete a Probe or Match

#### WebUI Procedure

1. Go to *Managed Devices :: Auto Discovery :: Hostname Detection*.

2. Select checkbox(es).

3. Click **Delete** .

4. On pop-up confirmation dialog, click **OK**.

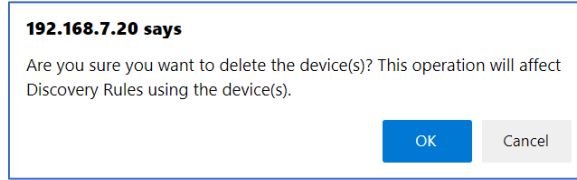

## Move Hostname Detection Priorities Up/Down

### WebUI Procedure

1. Go to *Managed Devices :: Auto Discovery :: Hostname Detection*.
2. Select the checkbox(es) of items.
3. Click **Up** or **Down** to move the sequence.

## Modify Hostname Detection Global Setting

### WebUI Procedure

1. Go to *Managed Devices :: Auto Discovery :: Hostname Detection*.

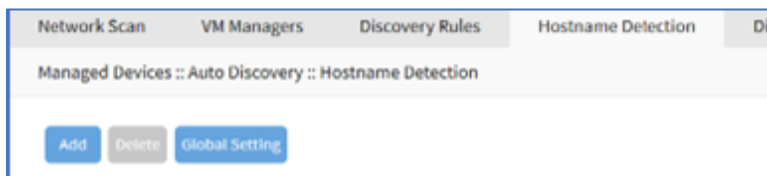

2. Click **Global Settings** (displays dialog).

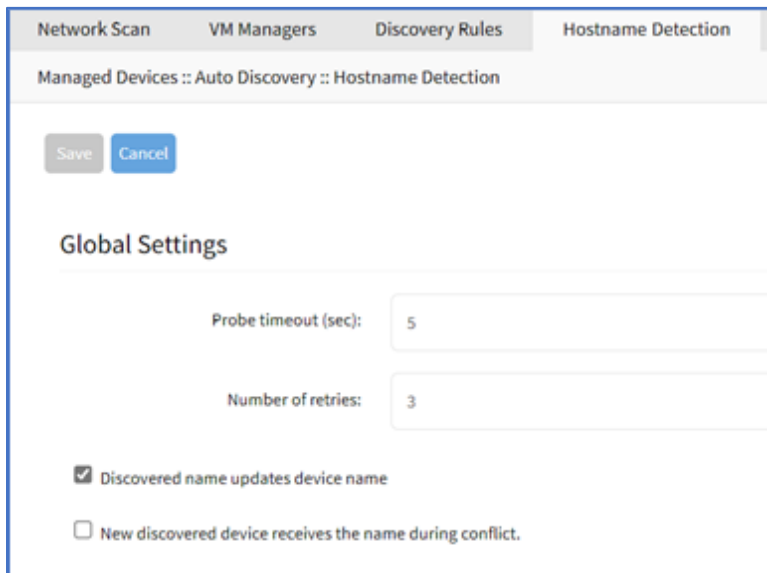

3. Enter **Probe timeout (sec)** (max time to wait for output) (default: 5).
4. Enter **Number of retries** (number of times probe is resent if no output) (default: 3).
5. Select **Discovered name updates device name** checkbox (enabled by default)  
 If disabled, no devices names are updated, even if a match is found.)

6. Select **New discovered device receives the name during conflict** checkbox.

If enabled, and multiple devices have the same name, the latest discovered device receives the name.

7. Click **Save**.

## Discovery Logs sub-tab

This displays the available Auto Discovery logs.

Network Scan VM Managers Discovery Rules Hostname Detection Discovery Logs Discover Now					
Managed Devices :: Auto Discovery :: Discovery Logs					Reload
Reset Logs					
Date	IP Address	Device Name	Discovery Method	Action	
Wed Oct 6 20:36:28 2021	127.0.0.1	nodegrid.localdomain	Network Scan	None	
Wed Oct 6 20:36:28 2021	127.0.0.2	whoarthou	Network Scan	None	
Wed Oct 6 20:36:29 2021	127.0.0.3	127.0.0.3	Network Scan	None	
Wed Oct 6 20:36:29 2021	127.0.0.4	127.0.0.4	Network Scan	None	

## Reset Logs

### WebUI Procedure

1. Go to *Managed Devices :: Auto Discovery :: Discovery Logs*.
2. Click **Reset Logs** (clears the table listing).

Network Scan VM Managers Discovery Rules Hostname Detection Discovery Logs Discover Now					
Managed Devices :: Auto Discovery :: Discovery Logs					Reload
Reset Logs					
Date	IP Address	Device Name	Discovery Method	Action	

## Discover Now sub-tab

Network Scan VM Managers Discovery Rules Hostname Detection Discovery Logs Discover Now					
Managed Devices :: Auto Discovery :: Discover Now					Reload
Discover Now					
<input type="checkbox"/>	Name	Type			
<input checked="" type="checkbox"/>	testtest	Network Scan			

## Start Discovery

### WebUI Procedure

1. Go to *Managed Devices :: Auto Discovery :: Discover Now*.
2. On the list, select checkboxes.
3. Click **Discover Now**.

This manually runs the auto discovery process for the selected item(s).

## Preferences tab

Administrators can define various preferences options that are applied to all sessions.

### Power Menu sub-tab

This configures preferences for defined order and labeling of the power menu as it appears in a console session.

### Edit Power Menu Settings

#### WebUI Procedure

1. Go to *Managed Devices :: Preferences :: Power Menu*.

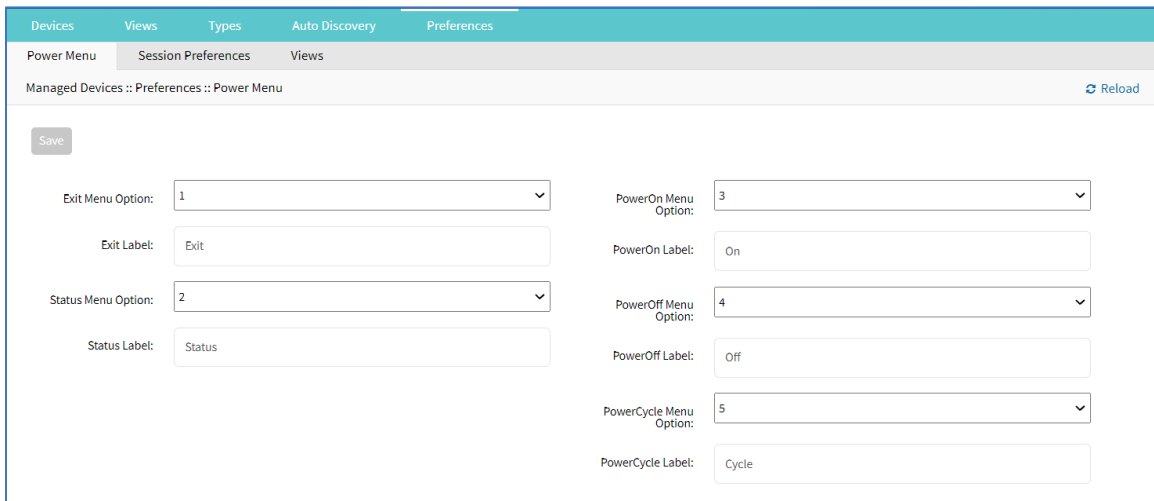

2. On **Exit Menu Option** drop-down, select one (0, 1, 2, 3, 4, 5, 6, 7, 8, 9).  
Enter **Exit Label**.
3. On **Status Menu Option** drop-down, select one (0, 1, 2, 3, 4, 5, 6, 7, 8, 9).  
Enter **Status Label**.
4. On **PowerOn Menu Option** drop-down, select one (0, 1, 2, 3, 4, 5, 6, 7, 8, 9).  
Enter **PowerOn Label**.
5. On **PowerOff Menu Option** drop-down, select one (0, 1, 2, 3, 4, 5, 6, 7, 8, 9).  
Enter **PowerOff Label**.
6. On **PowerCycle Menu Option** drop-down, select one (0, 1, 2, 3, 4, 5, 6, 7, 8, 9).

Enter **PowerCycle Label**.

7. Click **Save**.

## Session Preferences sub-tab

This defines session preferences. Often, it is difficult to exist a specific console session without affecting other sessions in the chain. The Disconnect HotKey closes the current active session in a chain. Configuring this hot key is useful when multiple sessions are open, i.e., a console session started from within a console session; or cascaded console sessions.

### Configure Disconnect HotKey to Terminate Session

#### WebUI Procedure

1. Go to *Managed Devices :: Preferences :: Session Preferences*.

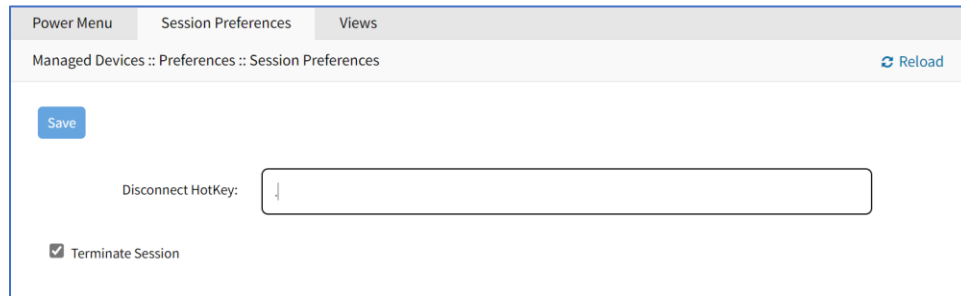

2. In **Disconnect HotKey**, create a key sequence that terminates the session.
3. Select **Terminate session** checkbox.

When enabled, on Disconnect HotKey, all connected sessions are closed – and the user is returned to the main shell prompt.

If disabled, on Disconnect HotKey, only the current session is closed.

4. Click **Save**.

## Views sub-tab

This changes how columns are displayed, as well as creating custom columns.

### Change Table Column Preferences

Column selections and arrangements are stored on the local computer. This column layout is not available when logged into another device.

#### WebUI Procedure

1. Go to *Managed Devices :: Preferences :: Views*.

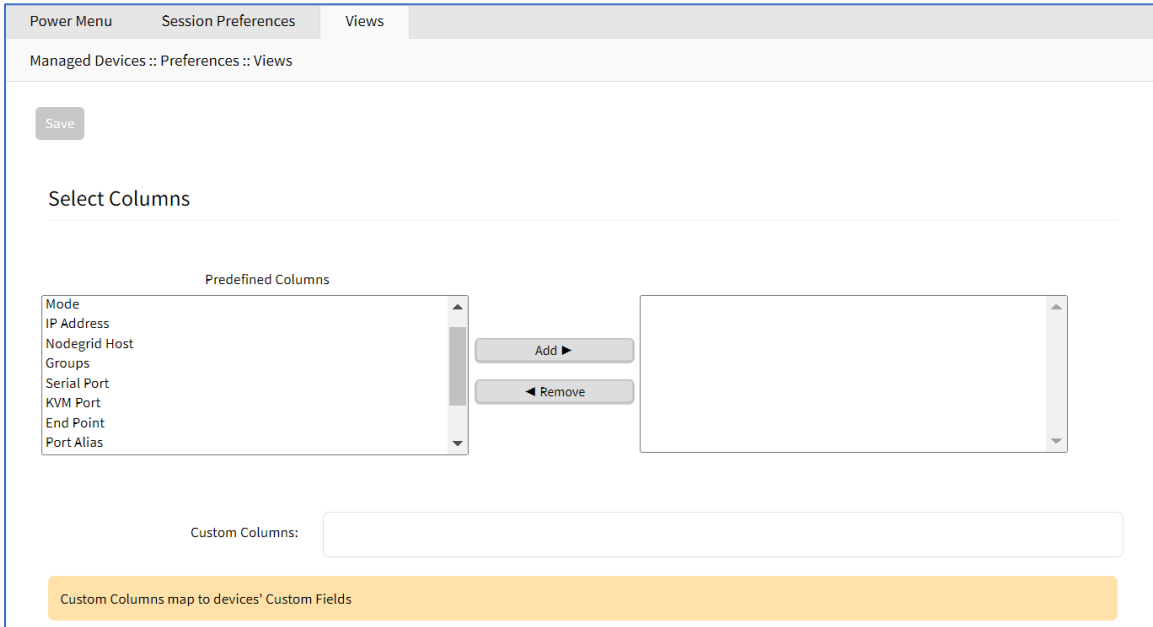

2. To add columns to right panel:  
In *Predefined Columns*, select and click **Add ▶**.
3. To remove columns from right panel:  
In right side panel, select and click **◀ Remove**.
4. Click **Save**.

### Step 1 – Create Custom Columns (per Device)

These provide additional organization of data on connected devices, custom columns can be created and enabled. This is a two-step process. First create the custom column, then add the custom column(s) to the individual device.

This two-step procedure connects the device's custom column to the device's custom field displayed in tables that contain that device's settings/values.

#### WebUI Procedure

1. Go to *Managed Devices :: Preferences :: Views*.
2. In the **Custom Columns** text box, enter the column name.

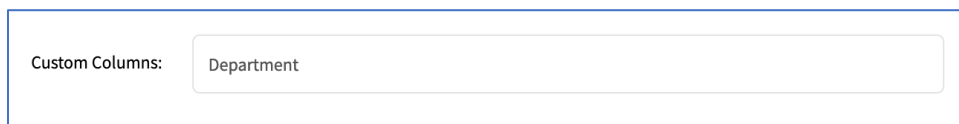

To add multiple columns, separate each name with a comma.

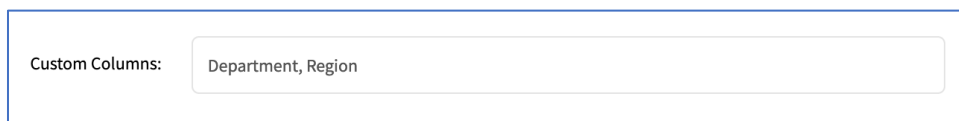



3. Click **Save**.

**NOTE:** The new custom column(s) do not appear on the *Access :: Devices* page until the associated device and column is enabled.

## Step 2 – Associate Device to the new Custom Field

### WebUI Procedure

1. Go to *Managed Devices :: Devices*.
2. Click the device name to be associated with the custom field.
3. On **Custom Fields** sub-tab, click **Add** (displays dialog).

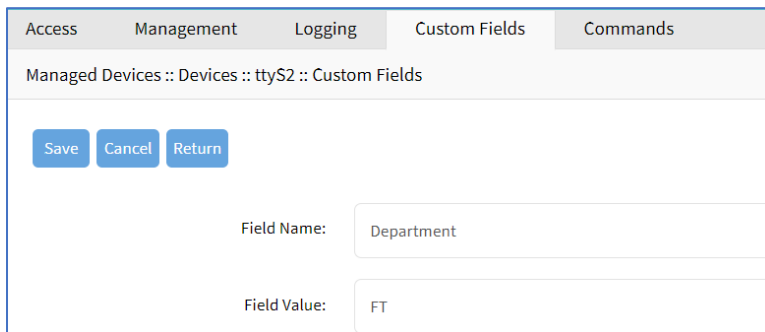

4. Enter **Field Name** (must exactly match name entered in the *Custom Columns* dialog).
5. Enter **Field Value**.
6. Click **Save**.

## Cluster Section

Cluster establishes a secure and resilient connection with a set of Nodegrid devices. When enabled, a Nodegrid device that is part of the Cluster can access and manage other devices. By logging into any Nodegrid device, all devices in the Cluster can be reached with a single interface. This allows for vertical and horizontal scalability.

There are two types of clustering topologies:

### STAR

This is the default option. In a star configuration, one Nodegrid unit acts as the coordinator and central node. All the other peers connect to the coordinator in a star formation. Only the coordinator has the list of all peers and attached devices within the configuration. This option allows centralized access and visibility from the coordinator Nodegrid device.

### MESH

In this configuration, one Nodegrid unit acts as the coordinator and all Nodegrid units (coordinator and peers) see each other (and all attached devices). This option allows for distributed access.

Each unit keeps a list of all peers and attached devices and demands equal system resources of all devices. This configuration is recommended for clusters of less than 50 units.

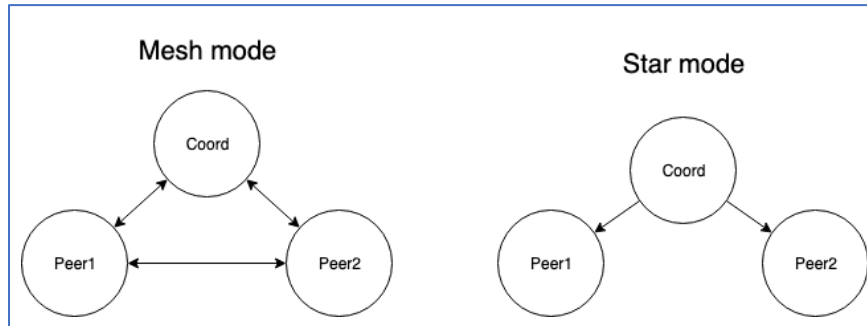

## Peers tab

This lists all Nodegrid devices enrolled in the cluster. The table shows information on each device.

Peers					
Cluster:: Peers					
Name	Address	Type	Status	Peer Status	
<input type="checkbox"/> masterX.localdomain	Local	Coordinator	Online	192.168.3.216,192.168.3.70	
<input type="checkbox"/> peerZ.localdomain	192.168.3.216	Peer	Online	192.168.3.208,192.168.3.70	
<input type="checkbox"/> peerY.localdomain	192.168.3.70	Peer	Online	192.168.3.208,192.168.3.216	

## Settings tab

This configures Cluster settings and additional services such as Peer Management and License Pool.

**NOTE:** The Cluster feature requires a software license for each node in the cluster.

## Enrollment sub-tab

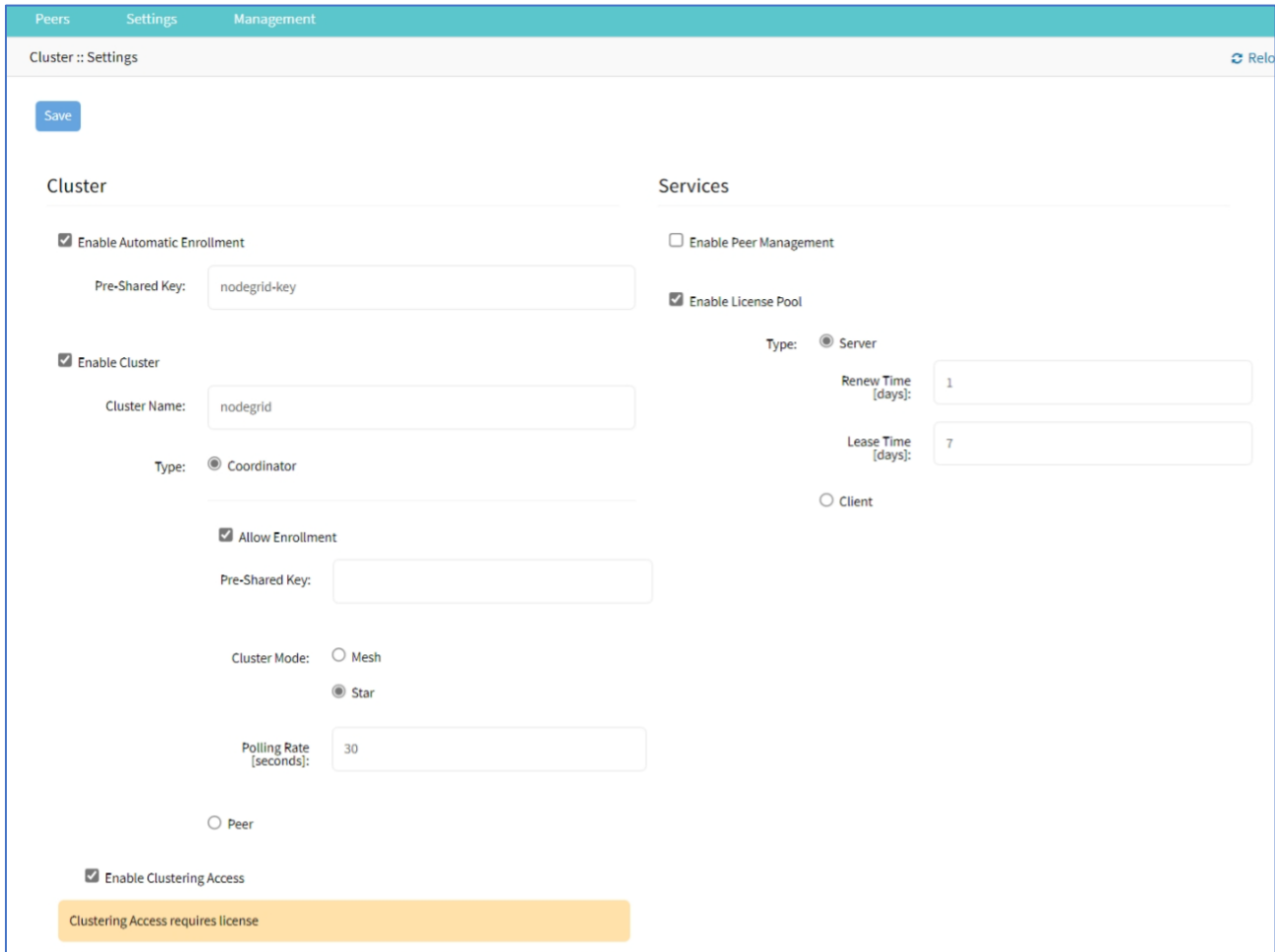

The screenshot shows the 'Cluster :: Settings' page with a 'Save' button at the top left. The interface is divided into two main sections: 'Cluster' and 'Services'.

**Cluster Section:**

- Enable Automatic Enrollment
  - Pre-Shared Key:
- Enable Cluster
  - Cluster Name:
  - Type:  Coordinator
  - Allow Enrollment
    - Pre-Shared Key:
  - Cluster Mode:  Mesh,  Star
  - Polling Rate [seconds]:
  - Peer
- Enable Clustering Access
  - Clustering Access requires license

**Services Section:**

- Enable Peer Management
- Enable License Pool
  - Type:  Server,  Client
  - Renew Time [days]:
  - Lease Time [days]:

## Description of Settings

### Automatic Enrollment

With Automatic Enrollment, new Nodegrid devices can automatically become available to an existing cluster. For Peers, this is enabled by default. The Pre-Shared Key setting must be the same on the Coordinator (set by default to **nodegrid-key**). The Interval setting only applies to the Coordinator and regulates how often invitations are sent to potential peers.

### Enable Cluster

When enabled, each Cluster requires one Coordinator that controls enrollment of peer systems. The first unit in the Cluster must be the Coordinator. All other units are Peers. When a Peer device is set to the Coordinator role, the change is automatically propagated. The previous Coordinator device is changed to Peer. Ensure the Coordinator device has Allow Enrollment selected. This provides a Cluster Name and Pre-Shared Key to enroll peers (and used in each Peer's settings). The Cluster Mode can be Star or Mesh.

In MESH, the Coordinator is only required for the enrollment of the peers. Once all Nodegrid systems were enrolled in the Cluster, the Coordinator can be set to Peer (prevents enrollment of other devices.)

## Peer Management

Allows Nodegrid device hardware to be centrally upgraded. The upgrade process for remote devices is done on the cluster's Management page. The firmware applied to the units must be hosted on a central location, available through a URL (URL should include the remote server's IP or hostname, file path, and the ISO file. If the status shows Disabled, that device is Peer Management disabled.

## License Pool

When enabled, the License Pool allows central management of all software licenses within a cluster. At least one device must be configured as the License Pool Server. In STAR mode, this must be the Coordinator. License Pool Clients automatically request required licenses from the License Pool Server. The Server checks availability and assigns as needed. The client sends a renew request based on the Renew Time. If client is unavailable for an extended time (exceeding the servers Lease Time), the client's licenses become invalid. The license is returned to the pool.

**NOTE:** Each Nodegrid device is shipped with five additional test target licenses. A test license is used automatically when a target license is added to the system. This also applies if a target license is applied on the License Pool Server. The first time a device requests target licenses, it requests five additional licenses to cover the currently used test licenses.

## Configure Cluster

### WebUI Procedure

1. Go to *Cluster :: Settings :: Enrollment*.
2. In the *Cluster* menu:

Select **Enable Automatic Enrollment** checkbox (expands dialog)

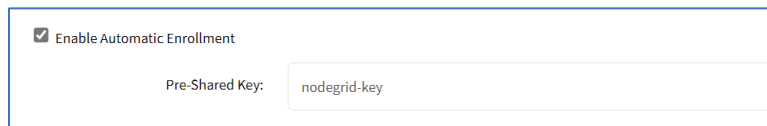

The screenshot shows a dialog box with a checked checkbox labeled "Enable Automatic Enrollment". Below it, there is a label "Pre-Shared Key:" followed by a text input field containing the value "nodegrid-key".

Enter **Pre-shared Key** (default: nodegrid-key).

Select **Enable Cluster** checkbox (allows other Nodegrid systems to manage, access, and search managed devices from other nodes) (expands dialog)

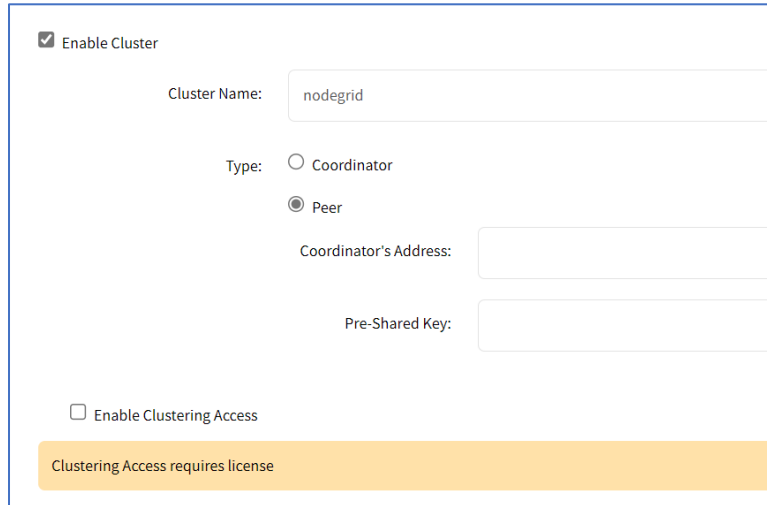

In *Type* menu, select one:

**Coordinator** radio button (expands dialog)

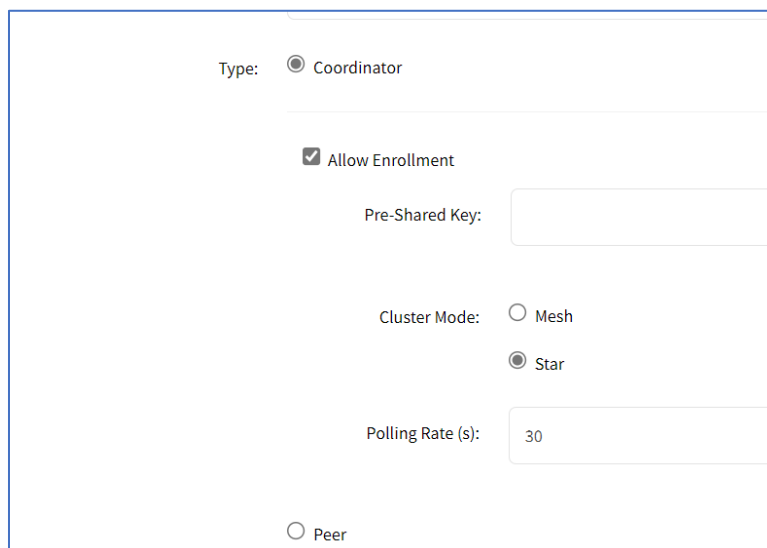

Enter **Pre-Shared Key**.

In *Cluster Mode* menu, select one radio button (**Star**, **Mesh**).

Enter **Polling Rate (s)**. (seconds)

**Peer** radio button (expands dialog)

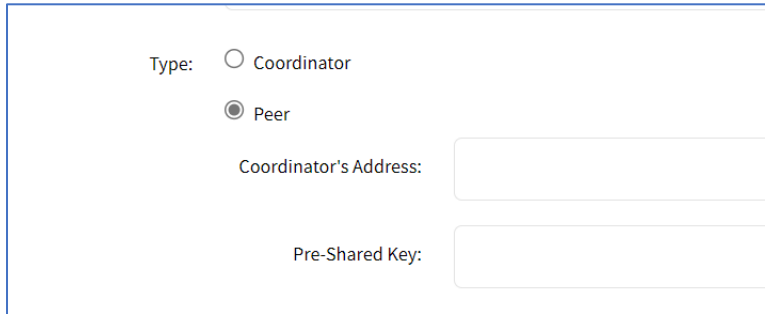

Enter **Coordinator's Address** (default: localhost).

Enter **Pre-Shared Key**.

Select **Enable Clustering Access** checkbox.

3. In *Services* menu:

Select **Enable Peer Management** checkbox.

Select **Enable License Pool** checkbox (expands dialog)

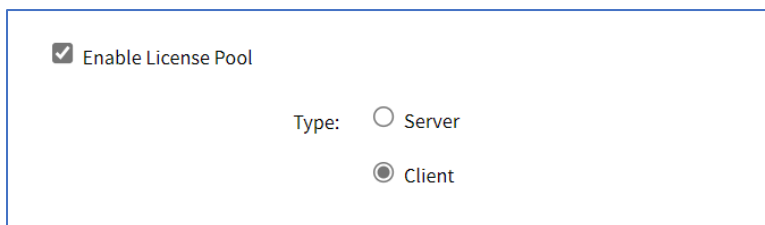

In *Type* menu, select one.

**Server** radio button (expands dialog)

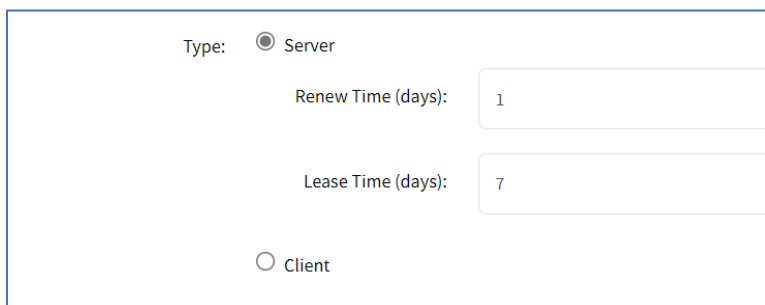

Enter **Renew Time (days)**.

Enter **Lease Time (days)** (7-30 days)

**Client** radio button

4. Click **Save**.

## Automatic Enrollment Range sub-tab

After the Coordinator is enabled and configured, the admin user can add a range of IPs for other Nodegrid devices on the network. This range eliminates the need to go to each Nodegrid node and manually set each as peers.

**NOTE:** It is recommended to only add IP's to the Automatic Enrollment Range which are potentially Nodegrid units. When set, invitations are continually sent to all IP's until a Nodegrid device is identified on a specific IP, and then is added to the Cluster.

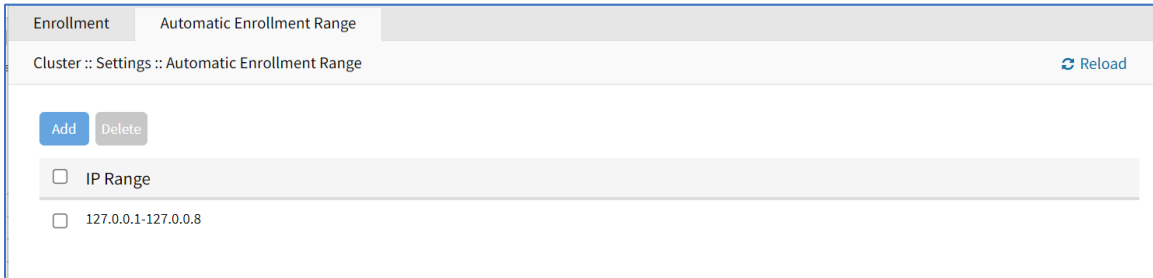

**NOTE:** An existing IP range setting cannot be modified. If an adjustment is needed, create a new IP range and delete the old IP range.

## Add Automatic Enrollment Range

### WebUI Procedure

1. Go to *Cluster :: Settings :: Automatic Enrollment Range*.
2. Click **Add** (displays dialog).

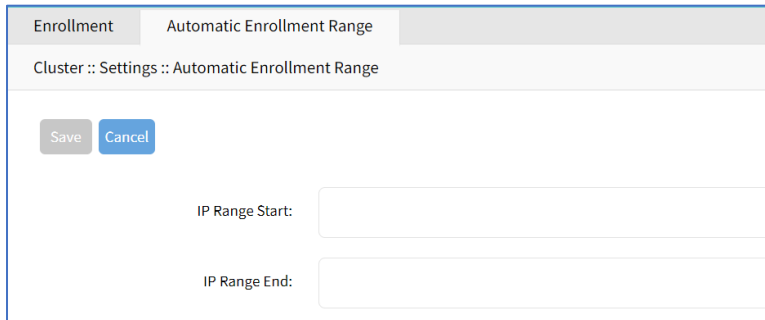

3. Enter **IP Range Start**.
4. Enter **IP Range End**.
5. Click **Save**.

## Delete Automatic Enrollment Range

### WebUI Procedure

1. Go to *Cluster :: Settings :: Automatic Enrollment Range*.
2. Select checkbox next to IP range to delete.
3. Click **Delete**.

- On confirmation pop-up dialog, click **OK**.

## Management tab

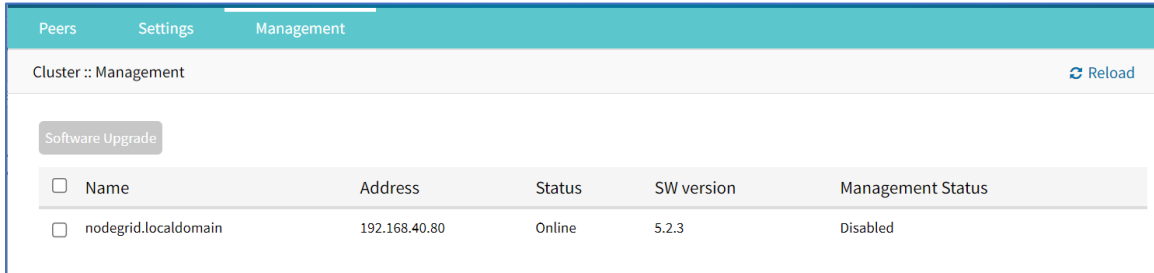

### Software Upgrade

To use the restore configuration option, the Nodegrid software version must match the version used to create the restoration file. For example: if the configuration file was created in version 4.2 and Nodegrid is currently on version 5.0, Nodegrid must be downgraded to version 4.2 before the restoration file can be used.

### Upgrade the Software

Software can be upgraded or downgraded on this procedure.

#### WebUI Procedure

- Go to *Cluster :: Management*.
- Select checkbox next to the name for software management.
- Click **Upgrade Software** (displays dialog).

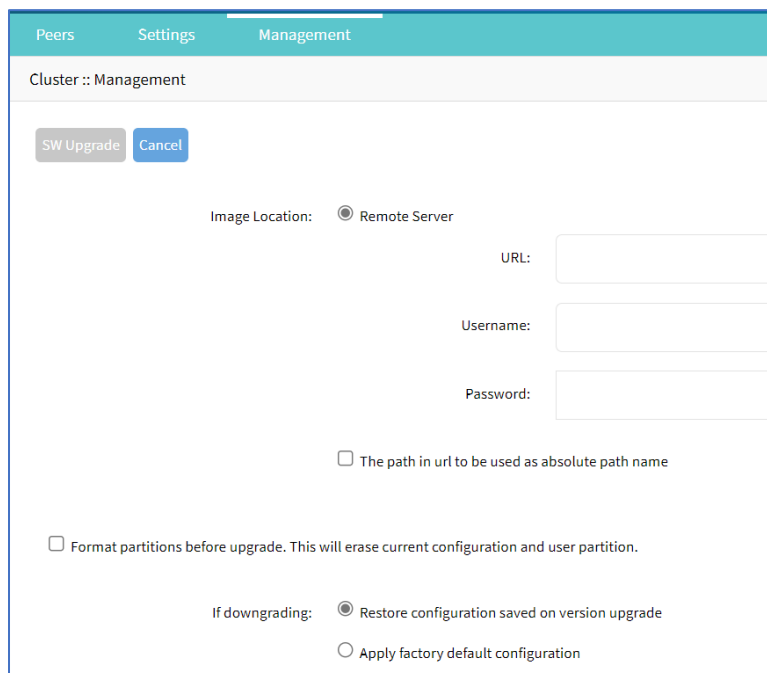



4. In *Image Location* menu, select **Remote Server**.  
 Enter **URL**.  
 Enter **Username**.  
 Enter **Password**.
5. (optional) Select **The path in url to be used as absolute path name** checkbox.
6. (optional) Select **Format partitions before upgrade. This will erase current configuration and user partition** checkbox.
7. (if applicable) In *If downgrading* menu (select one):  
**Restore configuration saved on version upgrade** radio button  
**Apply factory default configuration** radio button.
8. Review the details.
9. Click **SW Upgrade**.

## Security Section

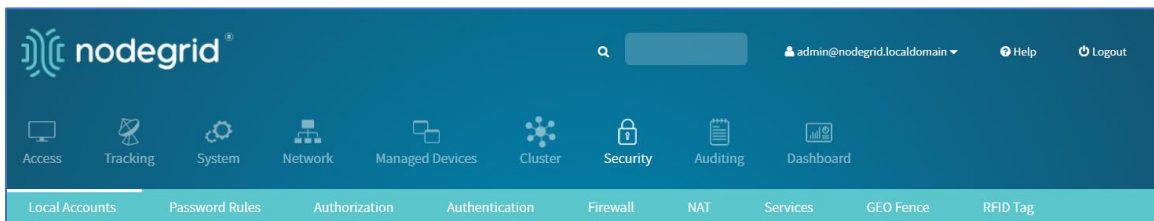

### Local Accounts tab

New local users can be added, deleted, changed, and locked. Administrators can force passwords to be changed upon next login, and set expiration dates for user accounts. Administrators can manage API keys for each account.

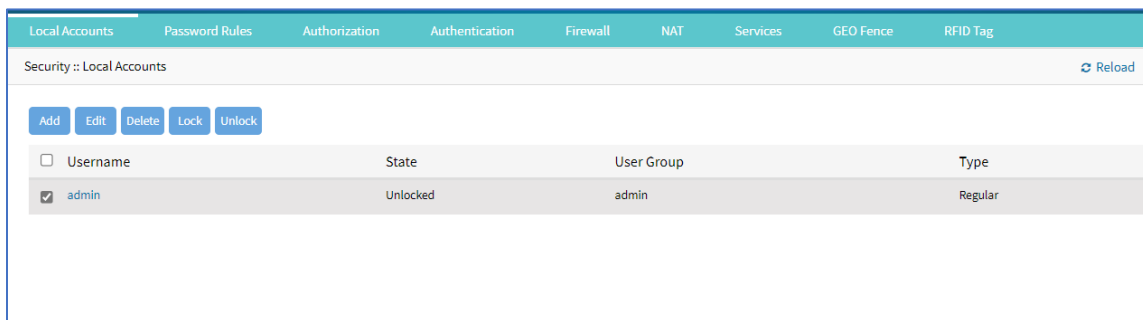

**NOTE:** Regardless of activation options, users can change their passwords at any time.

## Manage Local Users

### Add Local User

#### WebUI Procedure

1. Go to *Security :: Local Accounts*.
2. Click **Add** (displays dialog).

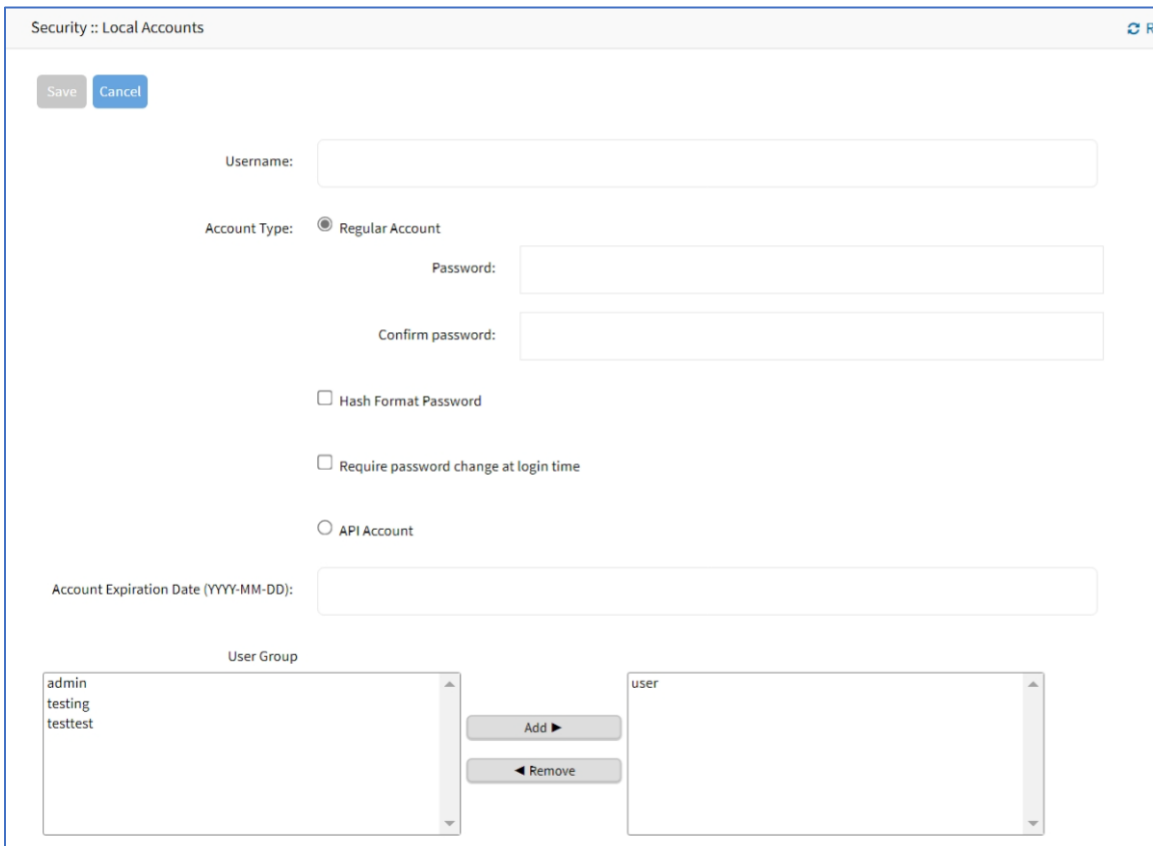

3. Enter **Username**.
4. In *Account Type* menu, select one.

#### **Regular Account** radio button

Enter **Password** and **Confirm Password**.

If the password is in a hash format, select **Hash Format Password** checkbox.

(as needed) Select **Require password change at login time** checkbox.

#### **API Account** radio button

On the **API Key**, follow this instruction: "Copy and store the API Key as it will not be possible to recover it after clicking on Save button."

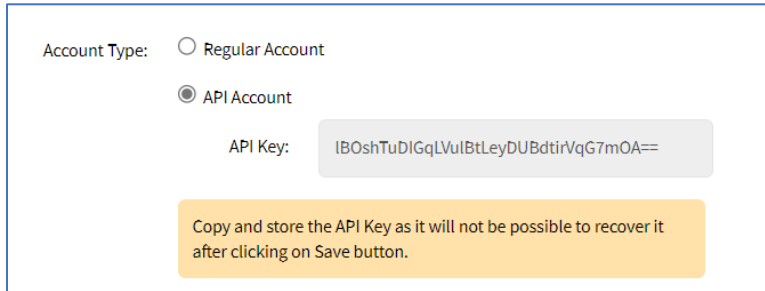

5. (optional) Enter **Account Expiration Date (YYYY-MM-DD)**.
6. In the *User Group* panel:
  - Select from left-side panel, click **Add ►** to move to right-side panel.
  - To remove from right-side panel, select, and click **◀ Remove**.
7. Click **Save**.

### Edit Local User

#### WebUI Procedure

1. Go to *Security :: Local Accounts*.
2. Locate and select checkbox next to username.
3. Click **Edit** (displays dialog).
4. Make changes as needed.
5. Click **Save**.

### Delete Local User

#### WebUI Procedure

1. Go to *Security :: Local Accounts*.
2. Locate and select checkbox next to username.
3. Click **Delete** (displays confirmation dialog).

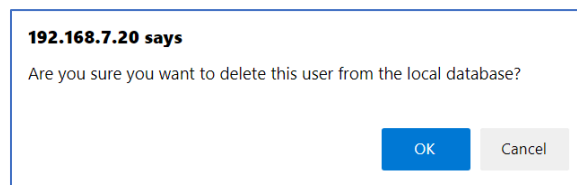

4. Click **OK**.

### Lock/Unlock Local User

#### WebUI Procedure

Generally, the administrator can lock a user out of the device.

1. Go to *Security :: Local Accounts*.
2. Locate and select checkbox next to username.
3. Click one:
  - Lock** (locks user out of device).
  - Unlock** (allows user access)

There is a function whereby the user is authorized by an external authentication provider (LDAP, AD, or TACACS+) and the Local user account is locked. The user can authenticate with the sshkey, but permissions are enforced based on his group permissions with the external authentication provider.

## Hash Format Password

As needed, the administrator can use a hash format password, rather than plain password. This can be used for scripts (avoids requiring scripts to use actual user passwords). The hash password must be generated separately beforehand. Use a hash password generator. These applications (OpenSSL, chpasswd, mkpasswd) use MD5, SHA256, SHA512 engines.

## Hash Format

### CLI Procedure

The Nodegrid Platform has an OpenSSL version. In the Console, use this:

```
root@nodegrid:~# openssl passwd -1 -salt mysall
Password:
$1$mysall$YBFr90n0wjde5be32mC1g1
```

## Generate a new API key for a user

In the *Type* column, the user must have a value of **API**.

### WebUI Procedure

1. Go to *Security :: Local Accounts*.
2. Locate and click the user’s name – *Type* column must be **API** (displays dialog).  
Alternatively, select checkbox and click **Edit**.

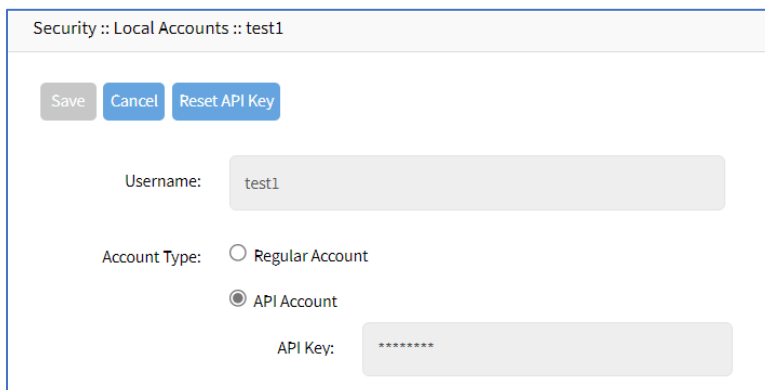

3. Click **Reset API Key**.

The new key is displayed in the API Key field. Copy the key and save in a secure location.

4. Click **Save**.

## Password Rules tab

When password rules are configured for the Nodegrid Platform, all local user accounts are subject. The administrator can set password complexity as well as password expiration.

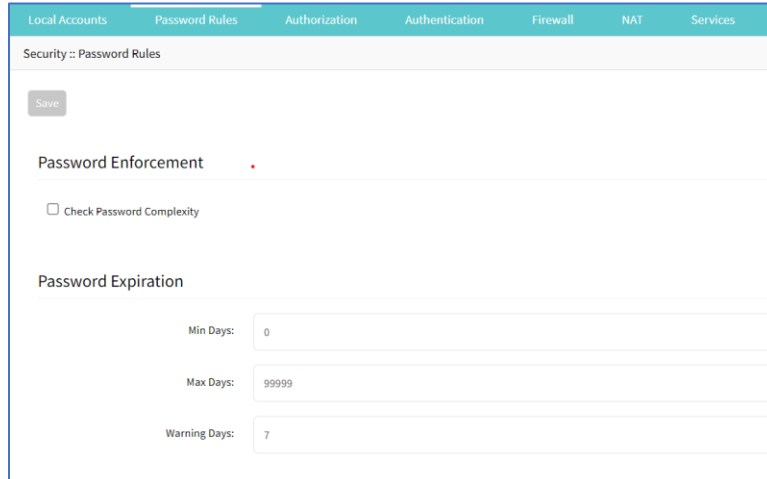

Local Accounts Password Rules Authorization Authentication Firewall NAT Services

Security :: Password Rules

Save

Password Enforcement

Check Password Complexity

Password Expiration

Min Days: 0

Max Days: 99999

Warning Days: 7

## Manage Password Rules

### Modify Password Rules

#### WebUI Procedure

1. Go to *Security :: Password Rules*.
2. In *Password Enforcement* menu

Select **Check Password Complexity** checkbox (expands dialog).

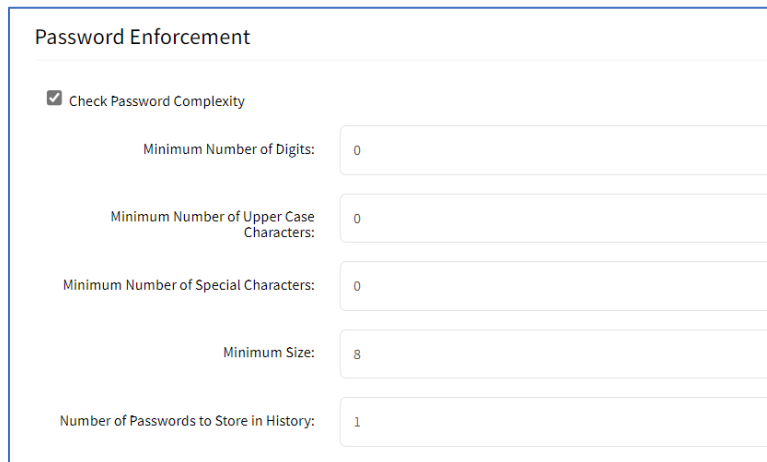

Password Enforcement

Check Password Complexity

Minimum Number of Digits: 0

Minimum Number of Upper Case Characters: 0

Minimum Number of Special Characters: 0

Minimum Size: 8

Number of Passwords to Store in History: 1

Enter **Minimum Number of Digits** (minimum characters in password).

Enter **Minimum Number of Upper Case Characters** (minimum upper case characters in password).

Enter **Minimum Number of Special Characters** (minimum special characters in password).

Enter **Minimum Size**. (minimum characters in password – default: 8).

Enter **Number of Passwords to Store in History** (the number of passwords stored in history to prevent reuse – default: 1).

3. In *Password Expiration* menu:

Enter **Min Days** (minimum days password must be valid before changed – default: 0).

Enter **Max Days** (maximum days password is valid before forcing change – default: 99999).

Enter **Warning Days** (days that users is notified before expiration – default: 7).

4. Click **Save**.

### **User Response to Expired Password**

When the password is configured to expire after a specified time, on user login, this is the response on the WebUI.

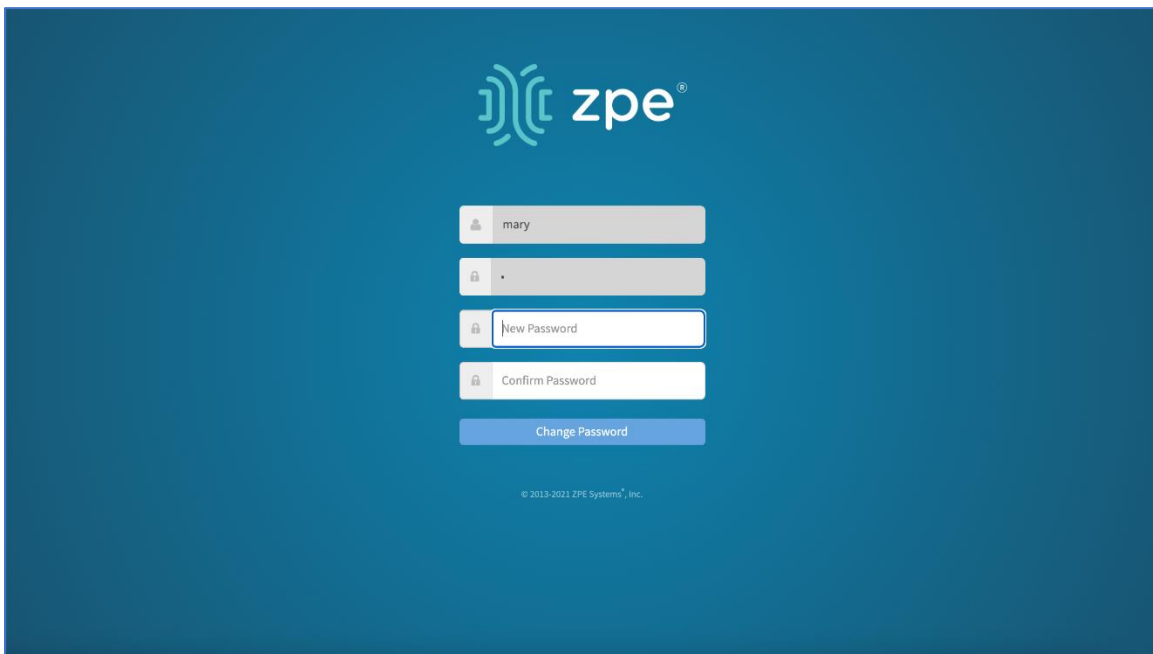

When this displays, enter **New Password** and **Confirm Password**, then click **Change Password**.

## **Authorization tab**

User groups combine multiple local and remote users into a single local group. Members are assigned group-specific roles/permissions. Members have access to devices assigned to that group. Groups which are authenticated against an external authentication provider are mapped to local groups. When

a user is assigned to a group, that user received the combined access rights. Administrators can add and delete groups, as well as change permissions. On the device's original configuration, two default groups are available: Admin and Users. The Admin group grants full system and target access.

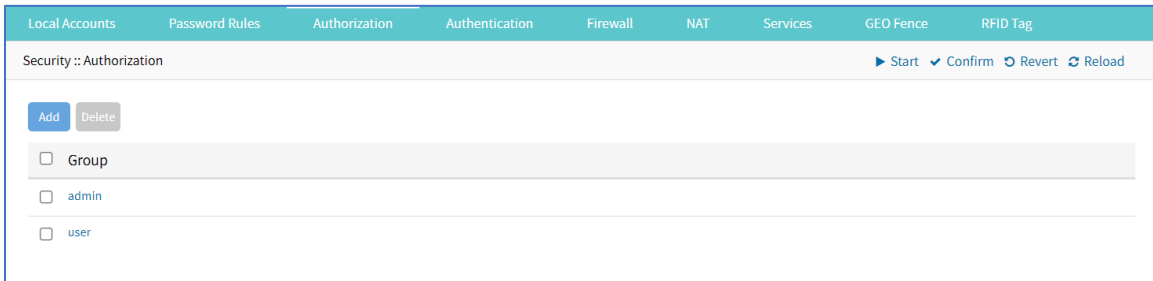

## User Group Configuration Process

This is the process to establish a User Group.

1. Create a user group
2. Add local and remote users to the group
3. Configure group system permissions and settings
4. Assign access to remote server groups
5. Add devices and configure permissions
6. Add and configure power outlet details

### Add User Group

#### WebUI Procedure

1. Go to *Security :: Authorization*.
2. Click **Add** (displays dialog).

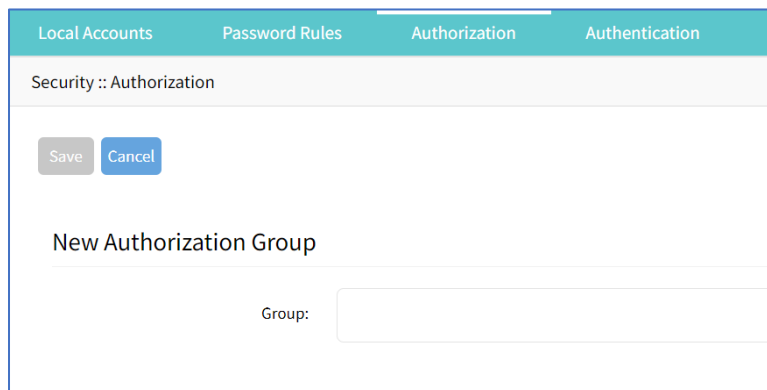

3. In **Group**, enter name of group.
4. Click **Save**.

## Delete User Group

### WebUI Procedure

1. Go to *Security :: Authorization*.
2. Select checkbox next to group to be deleted.
3. Click **Delete**.
4. On Confirmation dialog, click **OK**.

## User Group :: Members sub-tab

Groups are configured in this section. To access, click on an existing user group.

## Add Members to User Group

### WebUI Procedure

1. Go to *Security :: Authorization*.
2. Click the **Group Name**.
3. On **Members** sub-tab, click **Add** (displays dialog).

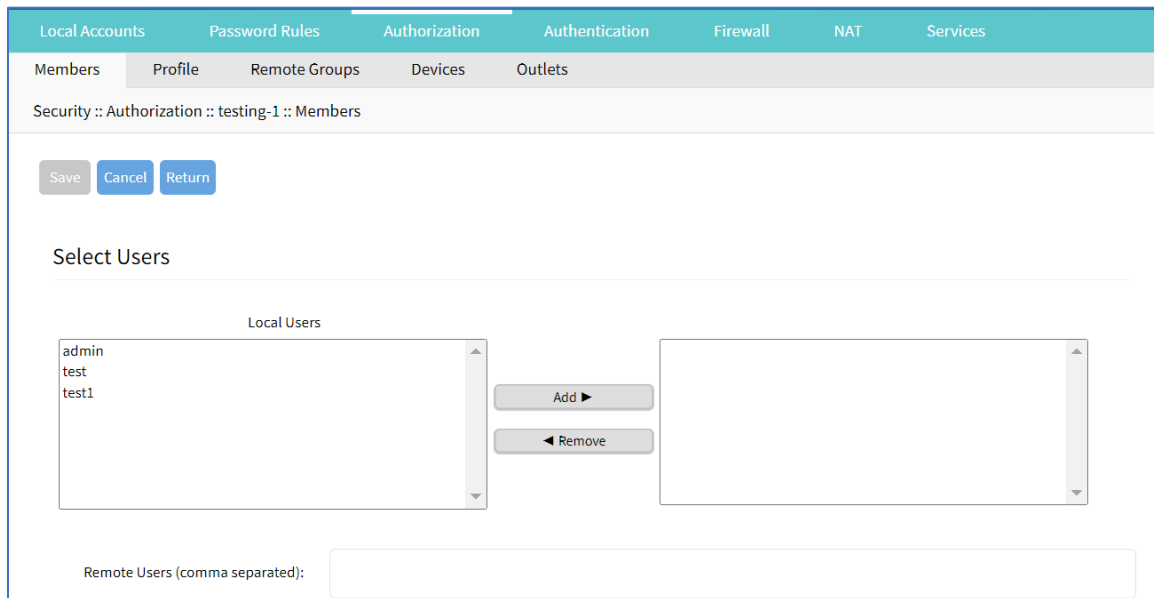

4. In the *Local Users* (left) panel:  
 Select from left-side panel, click **Add ►** to move to right-side panel.  
 To remove from right-side panel, select, and click **◀ Remove**.
5. Click **Save**.



## User Group: Profile sub-tab

### Apply System Permissions and Profile Settings

#### WebUI Procedure

1. Go to *Security :: Authorization*.
2. Click on the **Group Name**.
3. Click on the **Profile** sub-tab:

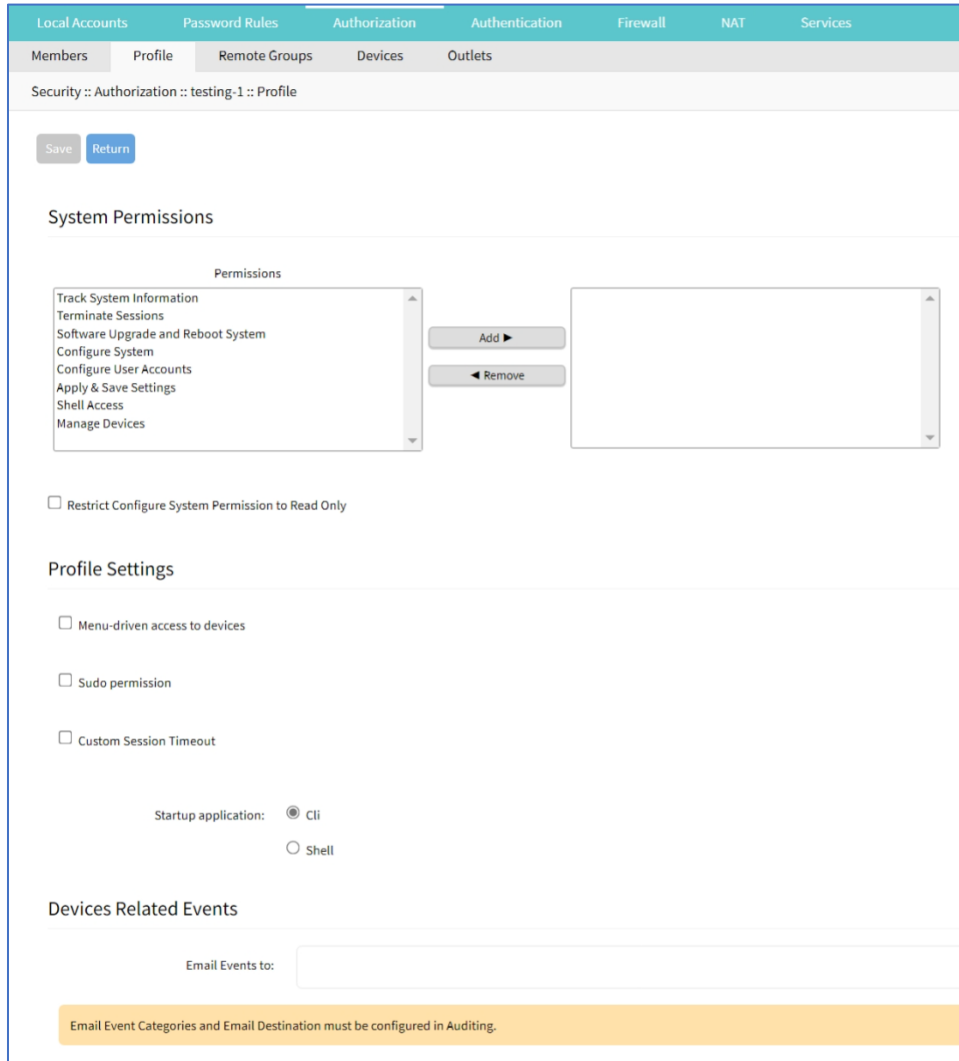

4. In *System Permissions* menu:

Select from left-side panel, click **Add ►** to move to right-side panel.

To remove from right-side panel, select, and click **◀ Remove**.

Select **Restrict Configure System Permission to Read Only** checkbox (granted system settings are visible but cannot be changed)

5. In *Profile Settings* menu:

Select **Menu-driven access to devices** checkbox (group members presented a target menu when SSH connection to the Nodegrid device is established).

Select **Sudo permission** checkbox (users can execute sudo commands).

Select **Custom Session Timeout** checkbox (enables a custom session time).

Enter **Timeout [seconds]**.

In *Startup application* menu, select one (**Cli, Shell**).

6. In *Devices Related Events* menu:

On **Email Events to**, enter email addresses (comma-separated).

**NOTE:** *Email Event Categories* and *Email Destination* are configured in the *Auditing* section.

7. Click **Save**.

## User Group: Remote Groups sub-tab

### Assign Remote Groups

External remote groups must be assigned to a local group. This ensures the remote group gets the correct permissions.

**NOTE:** This step is required for LDAP, AD, and Kerberos groups. Radius and TACACS+ authentication providers use other methods to link external groups/users to local groups.

#### WebUI Procedure

1. Go to *Security :: Authorization*.
2. Click on the **Group Name**,
3. On the **Remote Groups** sub-tab:

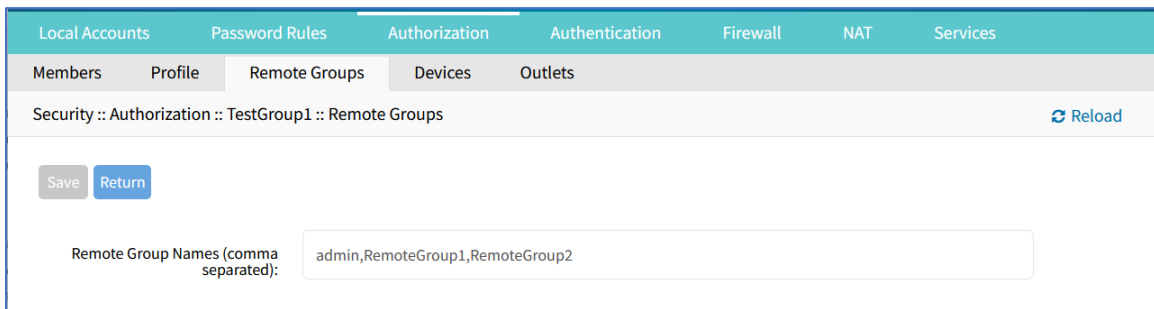

The screenshot shows the 'Remote Groups' sub-tab in the 'TestGroup1' group configuration. The breadcrumb path is 'Security :: Authorization :: TestGroup1 :: Remote Groups'. There are 'Save' and 'Return' buttons. A text input field labeled 'Remote Group Names (comma separated):' contains the text 'admin,RemoteGroup1,RemoteGroup2'.

In **Remote Group Names**, enter external group names (comma-separated).

4. Click **Save**.

## User Group: Devices sub-tab

Depending on system permission, access to specific devices can be assigned to groups. Devices must be added to the group. Appropriate access rights can be set. Multiple devices can be added at the same time.

**NOTE:** Access permissions to control power outlets are granted through the Outlets permissions and not through Devices

### Admin Group: Devices/Permissions

1. Go to *Security :: Authorization*.

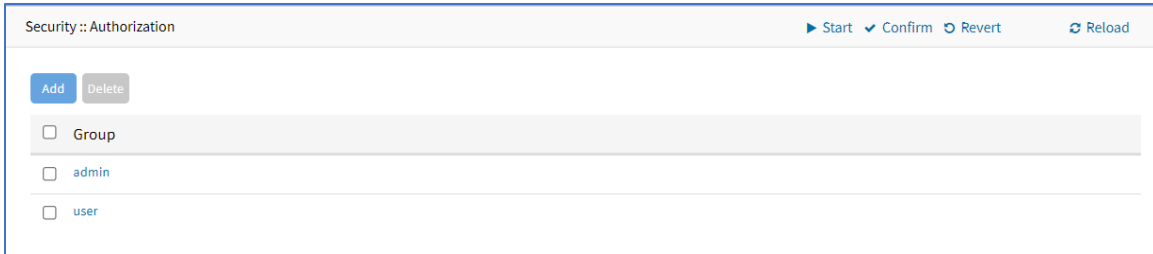

2. Click on **Admin** name and go to **Devices** sub-tab

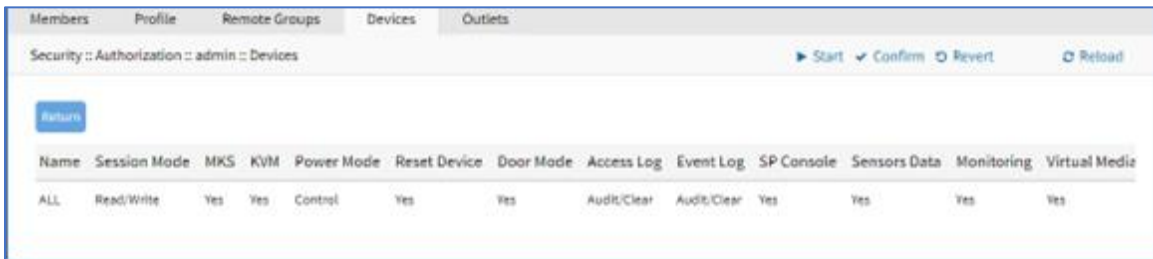

With the **ALL** configuration, admin users have all permissions to devices: Read/Write, Power, Command, etc.

**NOTE:** No additions/changes can be made to available devices or device permissions.

### Other Groups: Manage Devices/Permissions

1. Go to *Security :: Authorization*.

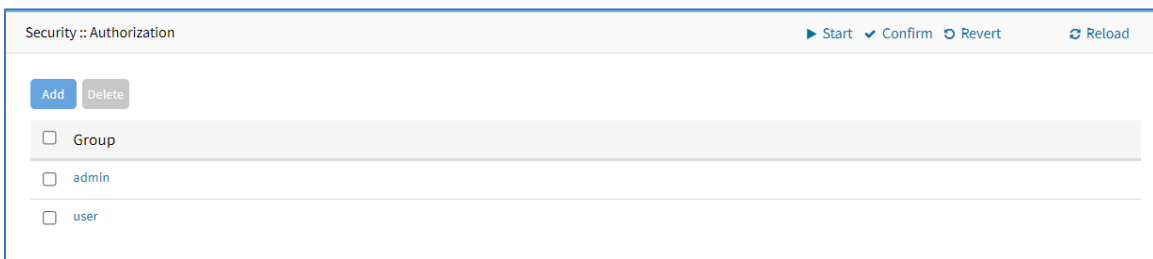

2. Click on **Users** (or other group name) and go to **Devices** sub-tab (displays dialog)

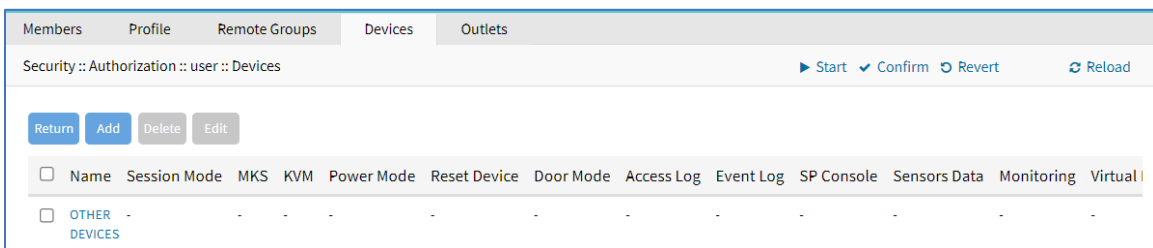

3. Click on **OTHER DEVICES** (displays dialog).

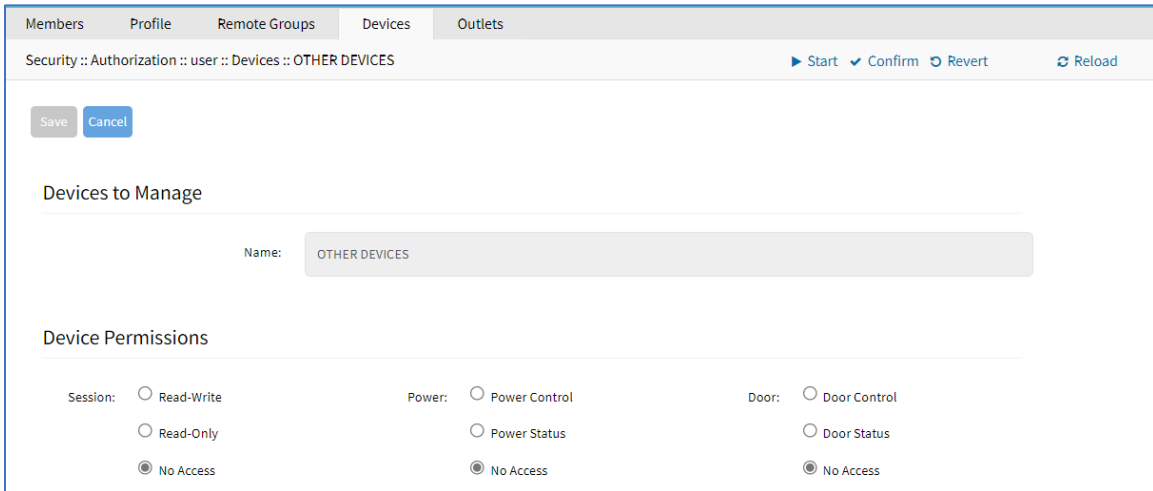

Members Profile Remote Groups **Devices** Outlets

Security :: Authorization :: user :: Devices :: OTHER DEVICES ▶ Start ▼ Confirm ↺ Revert ↻ Reload

Save Cancel

Devices to Manage

Name: OTHER DEVICES

Device Permissions

Session:  Read-Write  Read-Only  No Access

Power:  Power Control  Power Status  No Access

Door:  Door Control  Door Status  No Access

4. Device permissions are set for all devices in this group.
5. To add individual devices and set permissions, use the *Add Devices and Configure Permissions* procedure.

## Add Devices and Configure Permissions

### WebUI Procedure

1. Go to *Security :: Authorization*.
2. Click on the **Group Name**.
3. Click on the **Devices** sub-tab.

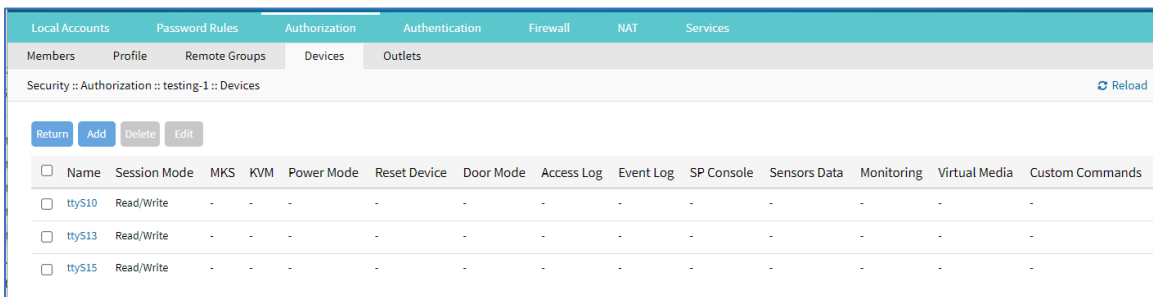

Local Accounts Password Rules Authorization Authentication Firewall NAT Services

Members Profile Remote Groups **Devices** Outlets

Security :: Authorization :: testing-1 :: Devices ↻ Reload

Return Add Delete Edit

<input type="checkbox"/>	Name	Session Mode	MKS	KVM	Power Mode	Reset Device	Door Mode	Access Log	Event Log	SP Console	Sensors Data	Monitoring	Virtual Media	Custom Commands
<input type="checkbox"/>	tty510	Read/Write	-	-	-	-	-	-	-	-	-	-	-	-
<input type="checkbox"/>	tty513	Read/Write	-	-	-	-	-	-	-	-	-	-	-	-
<input type="checkbox"/>	tty515	Read/Write	-	-	-	-	-	-	-	-	-	-	-	-

4. Click **Add** (displays dialog).

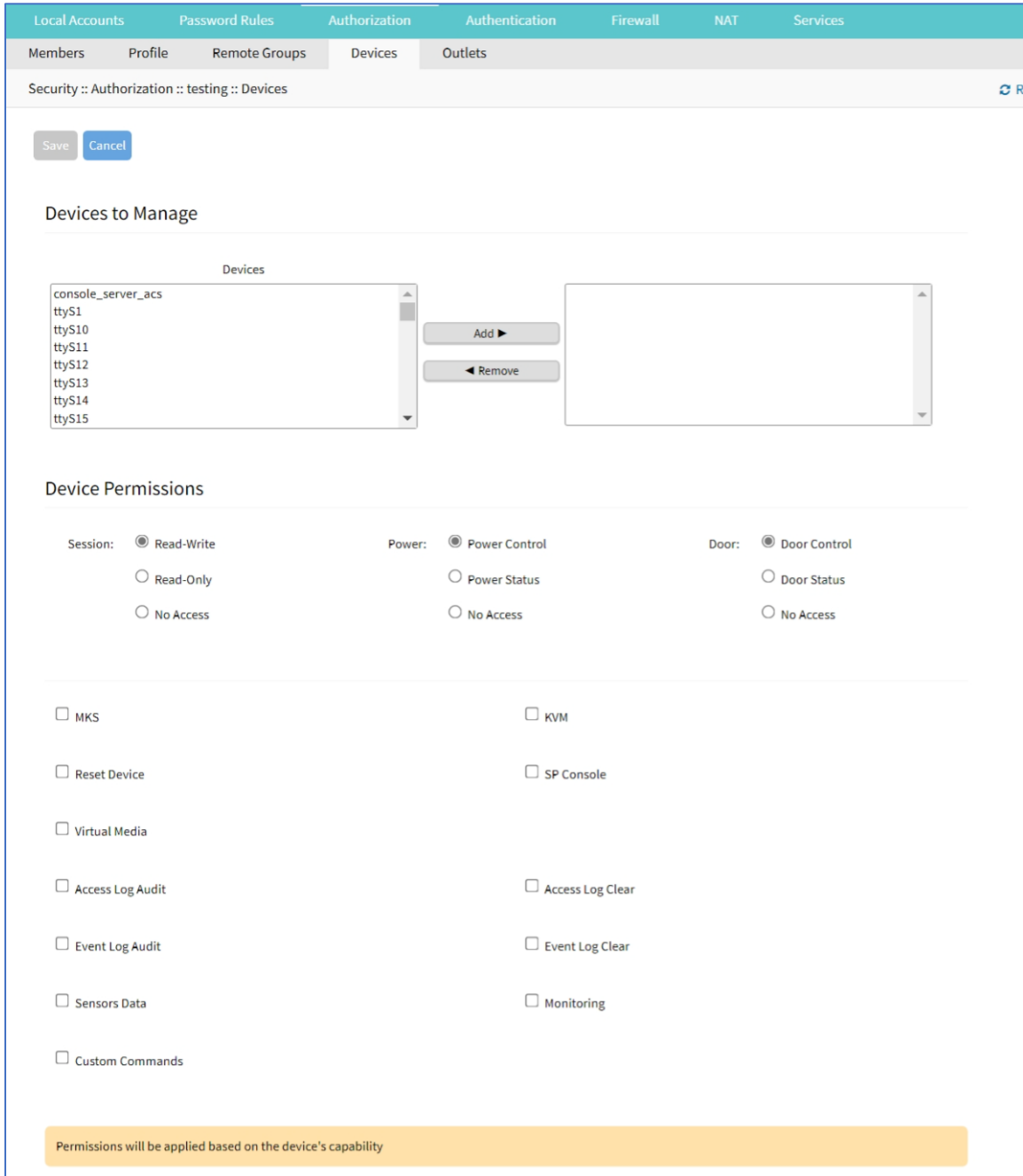

5. In *Devices to Manage* menu:

On *Devices* panel:

Select from left-side panel, click **Add ►** to move to right-side panel.

To remove from right-side panel, select, and click **◀ Remove**.

In *Device Permissions* menu:

In *Sessions* menu, select one (**Read-Write, Read-Only, No Access**).

In *Power* menu, select one (**Power Control, Power Status, No Access**).

In *Door* menu, select one (**Door Control, Door Status, No Access**)

6. (as needed) Select/unselect the following settings:

**MKS** (access to MKS sessions).

**KVM** (access to KVM sessions).

**Reset Device** (permission to reset a device session).

**SP Console** (access to IPMI console sessions - serial over LAN).

**Virtual Media** (access to start a Virtual Media session to an IPMI device).

**Access Log Audit** (access to read the access log of an IPMI device).

**Access Log Clear** (permission to clear the access log of an IPMI device).

**Event Log Audit** (permission to read the device-specific event log).

**Event Log Clear** (permission to clear the device-specific Event Log).

**Sensors Data** (permission to access monitoring features).

**Monitoring** (permission to read sensor data).

**Custom Commands** (permission to execute custom commands).

7. Click **Save**.

## Edit Device in Group

### WebUI Procedure

1. Go to *Security :: Authorization*.
2. Click on the **Group Name**.
3. Click on the **Devices** sub-tab.
4. In the **Name** column, click on the device name.  
Alternatively, select checkbox and click **Edit**.
5. Make changes as needed.
6. Click **Save**.

## Delete Device from Group

### WebUI Procedure

1. Go to *Security :: Authorization*.
2. Click on the **Group Name**.
3. Click on the **Devices** sub-tab.
4. Select checkbox and click **Delete**.

## User Group: Outlets sub-tab

### Add and Configure Power Outlets

Access permissions for power outlets from Rack PDUs are controlled individually as the power to turn on or off a device can have severe consequences for the running of a data center or remote location. The assignment of permissions is analogous to device's access permissions.

#### WebUI Procedure

1. Go to *Security :: Authorization*.
2. Click on the **Group Name**.
3. Click **Outlets** sub-tab.

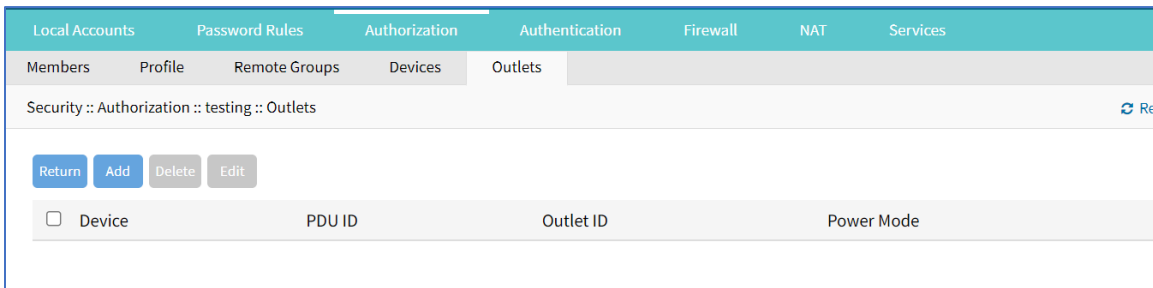

4. Click **Add** (displays dialog).

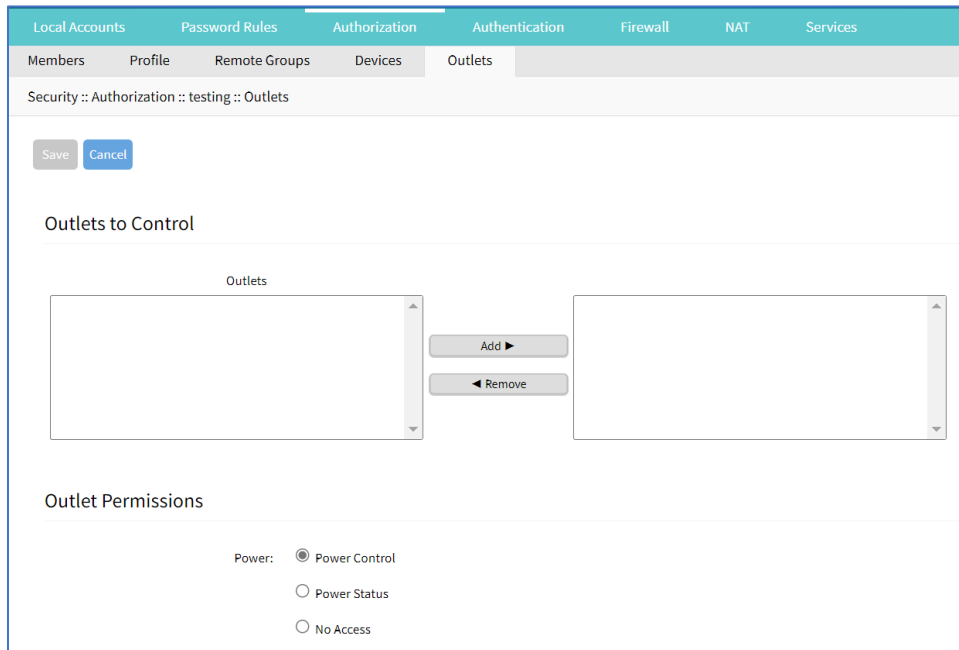

5. In *Outlets to Control* menu:

In *Outlets* panel:

Select from left-side panel, click **Add ►** to move to right-side panel.

To remove from right-side panel, select, and click **◀ Remove**.

- In *Outlet Permissions* menu, select one:
  - Power Control** radio button (permission to turn on or off an outlet)
  - Power Status** radio button (permission to see the current outlet status)
  - No Access** radio button (no access to outlet)
- Click **Save**.

## Configure SSH Key Authentication

The Nodegrid platform allows use of SSH keys for authorization. The feature is often used to allow automation systems to gain secure access without a password. It works well with direct Shell access and users who want to use SSH keys for a local home directory. This feature is available for all local, LDAP, AD, and TACACS+ users. Radius users cannot use SSH keys for authentication.

### Configure SSH Key Authorization

#### WebUI Procedure

- Go to *Security :: Authorization*.
- In the Group column, click on a name.
- On the group's **Profile** sub-tab:
  - In *Startup application* menu:
    - Select **Shell** radio button (gives group members default shell access, and not CLI access, on connection via SSH).
  - Click **Save**.
- Go to *Security :: Local Accounts*.
- Create a local user and add to the new group.

The SSH key can be used for authentication. The default SSH tools can copy the SSH key to the Nodegrid device (i.e., SSH-copy-id).

**NOTE:** If the user needs default CLI access, and not Shell access, remove the user from the newly created Group.

## Authentication tab

Authentication validates the user, usually with credentials that, most often, take the form of a username and password. Authorization is an essential security feature that complements authentication. Once authenticated with credentials, authorization determines access (i.e., directories, functions, features, and displays).



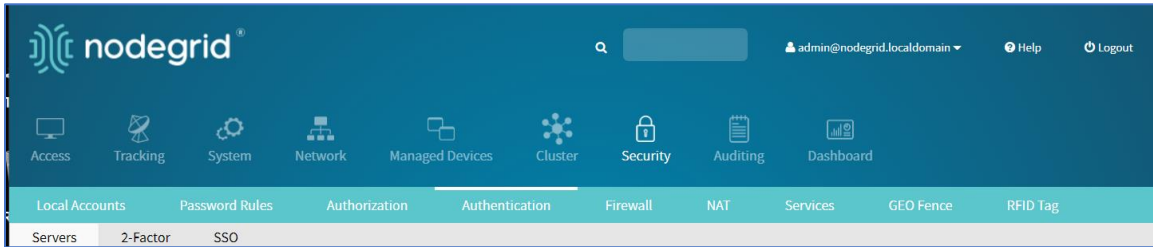

Nodegrid devices have a built-in admin user account named 'admin'. This has full access and rights to all configurable unit functions: network, security, authentication, authorization, managed devices, including other users. The admin account cannot be deleted (initial default password: admin).

**NOTE:** For security reasons, during the first login, administrators are immediately required to change the default password. Use the Change Password option on the pull-down menu under the username (upper right corner of the WebUI).

Authentication of local users and groups is fully supported, as well as external users and groups. External authentication of users and groups can be done through LDAP/AD, TACACS+, Radius and Kerberos.

By default, all users have access to enabled managed devices. Based on assigned groups, users have limited access to Nodegrid Web portal management attributes. User privileges can be modified with profile and access rights in an authorization group.

A user in the Admin group has the same administrative privileges as the initial admin user. Each user must have a specific user account on a Nodegrid device. An external authentication server can provide authenticated access. A user can be assigned to one or more groups.

**NOTE:** The device's root user and Admin group users can still bypass 2-Factor Authentication in Console and WebUI, in case the remote server is unreachable.

## Servers sub-tab

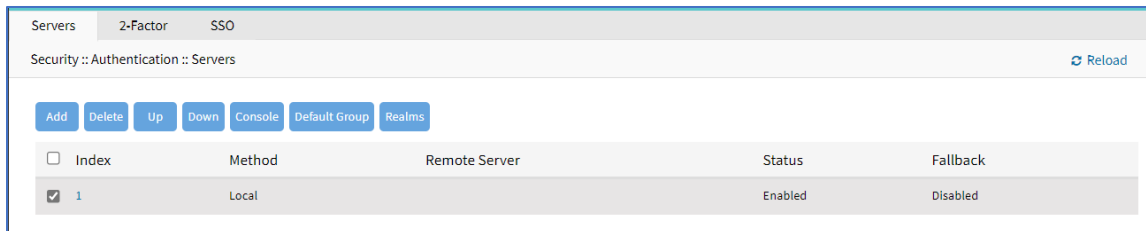

## Add a server

### WebUI Procedure

1. Go to *Security :: Authentication :: Servers*.
2. Click **Add** (displays dialog).

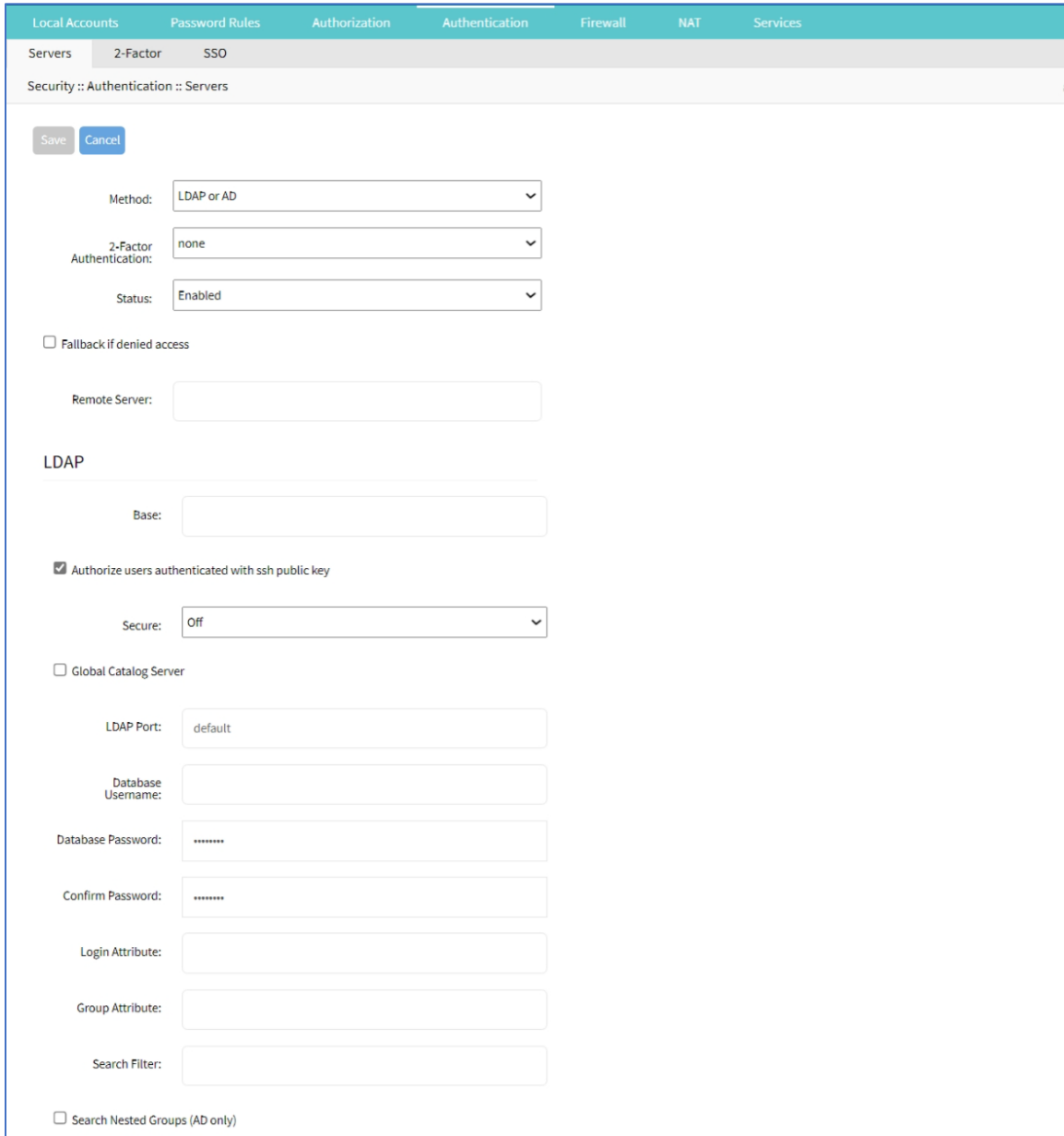

3. On **Method** drop-down, select one (**LDAP or AD, RADIUS, TACACS+, Kerberos**). (Additional options display, depending on selection).
4. On **2 Factor Authentication** drop-down, select one (**None, Enabled**).
5. On **Status** drop-down, select one (**Enabled, Disabled**).
6. Select **Fallback if denied access** checkbox.
7. Enter **Remote Server** (IP address of remote server).

8. If **Method** selection is: **LDAP or AD** (displays dialog).

LDAP

Base:

Authorize users authenticated with ssh public key

Secure:

Global Catalog Server

LDAP Port:

Database Username:

Database Password:

Confirm Password:

Login Attribute:

Group Attribute:

Search Filter:

Search Nested Groups (AD only)

Enter **Base** (root DN or a sublevel DN – highest point used to search for users or groups).

Select **Authorize users authenticated with ssh public key** checkbox (default: disabled).

On **Secure** drop-down, select one (**On**, **Off**, **Start\_TLS**) (default: Off).

Select **Global Catalog Server** checkbox (if enabled, uses an Active Directory Global Catalog Server).

Enter **LDAP Port** (or accept "default").

Enter **Database Username**.

Enter **Database Password**.

Enter **Confirm Password**.

Enter **Login Attribute** (contains username - for AD, default: sAMAccountName).

Enter **Group Attribute** (group identifier - for AD, default: memberOf).

Enter **Search Filter**.

Select **Search Nested Groups (AD only)** checkbox (default: disabled).

Enter **Group Base**.

**Example: OpenLDAP Configuration**

Status: True; Fallback if denied access: True; Remote Server: 192.168.1.1; Base: dc=zpe, dc=net; Secure: Off; Global Catalog Server: False; Database Username: cn=admin, dc=zpe, dc=net; Login Attribute: cn; Group Attribute: Member, UID

**Example: Active Directory Configuration**

Status: True; Fallback if denied access: True; Remote Server: 192.168.1.1; Base: dc=zpesystems, dc=com; Secure: Start TLS!; Global Catalog Server: True; Database Username: cn=Administrator, cn=Users, dc=zpesystems, dc=com; Login Attribute: sAMAccountName; Group Attribute: memberOf

9. If **Method** selection is: **RADIUS** (displays dialog).

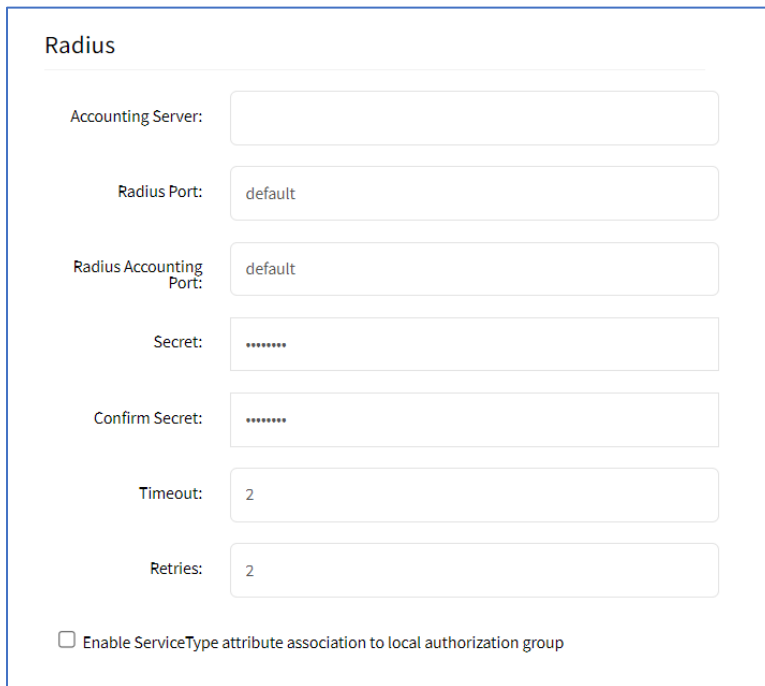

Enter **Accounting Server**.

Enter **Radius Port** (or accept "default").

Enter **Radius Accounting Port** (or accept "default").

Enter **Secret** and **Confirm Secret**.

Enter **Timeout**.

Enter **Retries**.

Select **Enable ServiceType attribute association to local authorization group** checkbox (allows assignment of Radius Service Types to Nodegrid local groups).

+++++

**Configure Nodegrid as a FreeRadius Server - CLI Procedure (example)**

1. Create the file "/usr/share/freeradius/dictionary.zpe" with the content listed below:

```
VENDOR ZPE 42518
BEGIN-VENDOR ZPE
    ATTRIBUTE ZPE-User-Groups 1 string
END-VENDOR ZPE
```

2. Edit the file "/usr/share/freeradius/dictionary". In the file, add a line with dictionary.zpe (suggested location).

```
$INCLUDE dictionary.zpe
$INCLUDE dictionary.jradius
```

3. In /etc/freeradius/users, assign user groups. Define the "Framed-Filter-ID" attribute (as before) or define a new attribute "ZPE-User-Groups".

**NOTE:** If both attributes are defined, "ZPE-User-Groups" takes precedence.

```
rad-edmond      Cleartext-Password := "*****"
                Service-Type = Framed-User,
                Framed-Protocol = PPP,
                Framed-Filter-Id = "group_name=filter-grp1, filter-
grp2;",
                ZPE-User-Groups = "vsa-grp1, vsa-grp2",
                Framed-MTU = 1500,
                Framed-Compression = Van-Jacobsen-TCP-IP
```

+++++

10. If **Method** selection is: **TACACS+** (displays dialog).

Tacacs+

Accounting Server:

Authorize users authenticated with ssh public key

TACACS+ Port:

Service:  ▼

Secret:

Confirm Secret:

Timeout:

Retries:

TACACS+ Version:  ▼

Enable User-Level attribute of Shell and raccess services association to local authorization group

Enter **TACACS+ Port** (default: 49).

On **Service** drop-down, select one (**PPP, Shell, raccess**) (default: raccess).

Enter **Secret**.

Enter **Confirm Secret**.

Enter **Timeout**.

Enter **Retries**.

On **TACACS+ Version** drop-down, select one (**V0, V1, V0\_V1, V1\_V0**).

Select **Enable User-Level attribute of Shell and raccess services association to local authorization group** checkbox.

11. If **Method** selection is: **Kerberos** (displays dialog).

Kerberos

Realm Domain Name:

Domain Name:

Enter **Realm Domain Name**.

Enter **Domain Name**.

12. Click **Save**.

## Set 2-Factor Authentication for Admin/Root Users

### WebUI Procedure

1. Go to *Security :: Authentication :: Servers*.
2. In *Index* column, click the index to be updated (displays dialog).

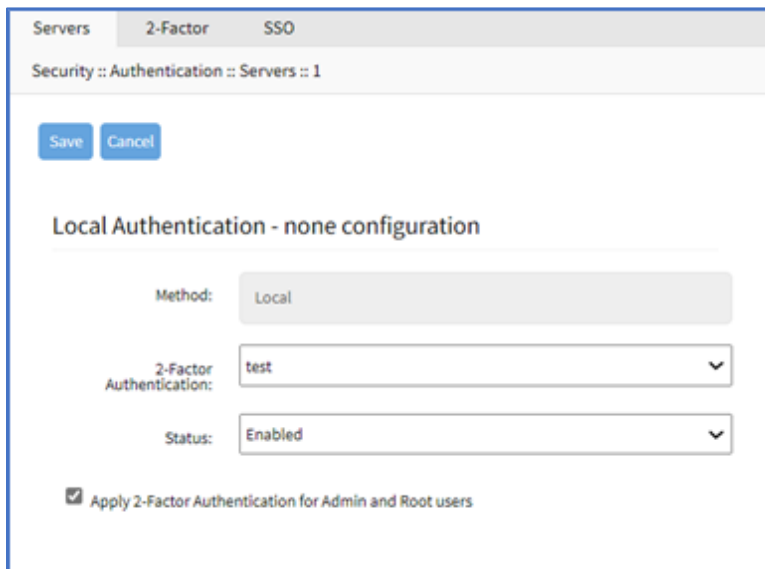

The screenshot shows a configuration window titled 'Security :: Authentication :: Servers :: 1'. It has 'Save' and 'Cancel' buttons at the top left. The main section is 'Local Authentication - none configuration'. It contains three dropdown menus: 'Method' set to 'Local', '2-Factor Authentication' set to 'test', and 'Status' set to 'Enabled'. At the bottom, there is a checked checkbox with the label 'Apply 2-Factor Authentication for Admin and Root users'.

3. Select **Apply 2-Factor Authentication for Admin and Root users** checkbox (if not selected, Admin and Root roles can use single logon).
4. Click **Save**.

## Edit a Server

### WebUI Procedure

1. Go to *Security :: Authentication :: Servers*.
2. In *Index* column, click the index to be updated (displays dialog).
3. Make changes, as needed.
4. Click **Save**.

## Delete a Server

### WebUI Procedure

1. Go to *Security :: Authentication :: Servers*.
2. Locate and select checkbox.

3. Click **Delete**.
4. On the confirmation pop-up dialog, click **OK**.

### Move Index Priority Up/Down

#### WebUI Procedure

1. Go to *Security :: Authentication :: Servers*.
2. Locate and select checkbox.
3. Click **Up** to move the selection up in the table.
4. Click **Down** to move the selection down in the table.
5. Click **Save**.

### Enable/disable Console Authentication

#### WebUI Procedure

1. Go to *Security :: Authentication :: Servers*.
2. Locate and select checkbox).
3. Click **Console** (displays dialog).

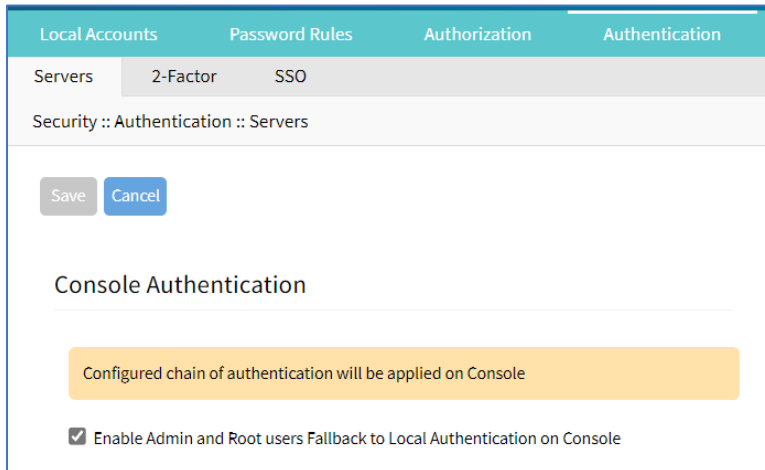

4. (as needed) Select/unselect **Enable Admin and Root users Fallback to Local Authentication on Console** checkbox.
5. Click **Save**.

### Set Default Group

#### WebUI Procedure

1. Go to *Security :: Authentication :: Servers*.
2. Locate and select checkbox.
3. Click **Default Group** (displays dialog).



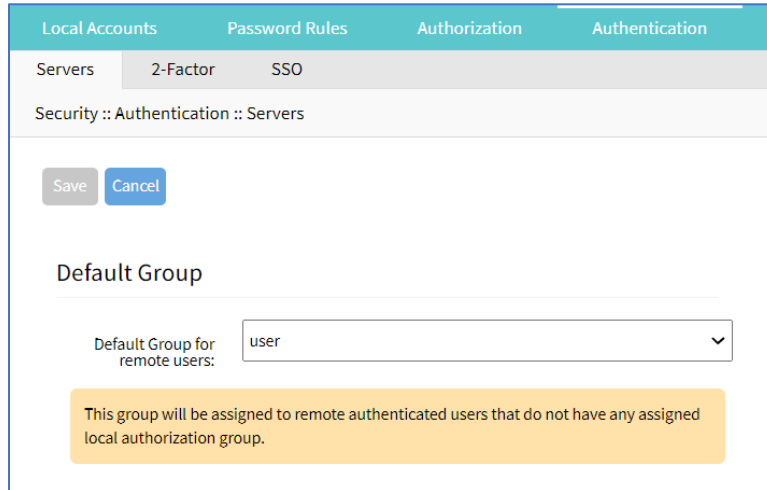

4. On the **Default Group for Remote Server** drop-down, select one.
5. Click **Save**.

### Set Realms

Realms allow the user to select authentication server when logging in with the notation `user@server` or `server\user`

#### WebUI Procedure

1. Go to *Security :: Authentication :: Servers*.
2. Locate and select checkbox.
3. Click **Realms** (displays dialog).

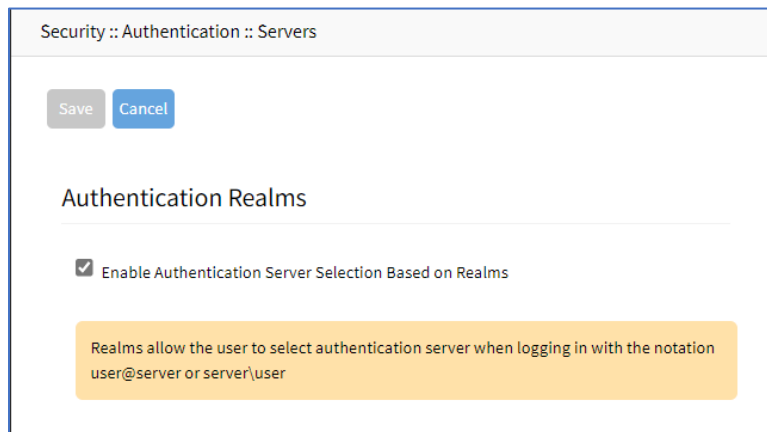

4. Select **Enable Authentication Server Selection Based on Realms** checkbox.
5. Click **Save**.

### 2-Factor sub-tab

This sets up 2-factor authentication.

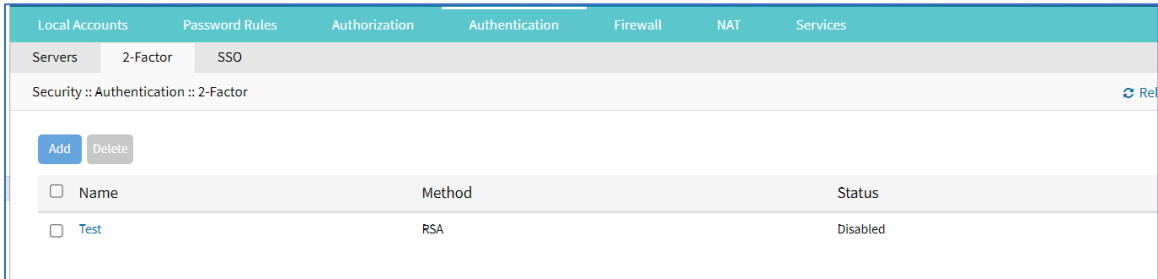

## Add 2-Factor Configuration

### WebUI Procedure

1. Go to *Security :: Authentication :: 2-Factor*.
2. Click **Add** (displays dialog)

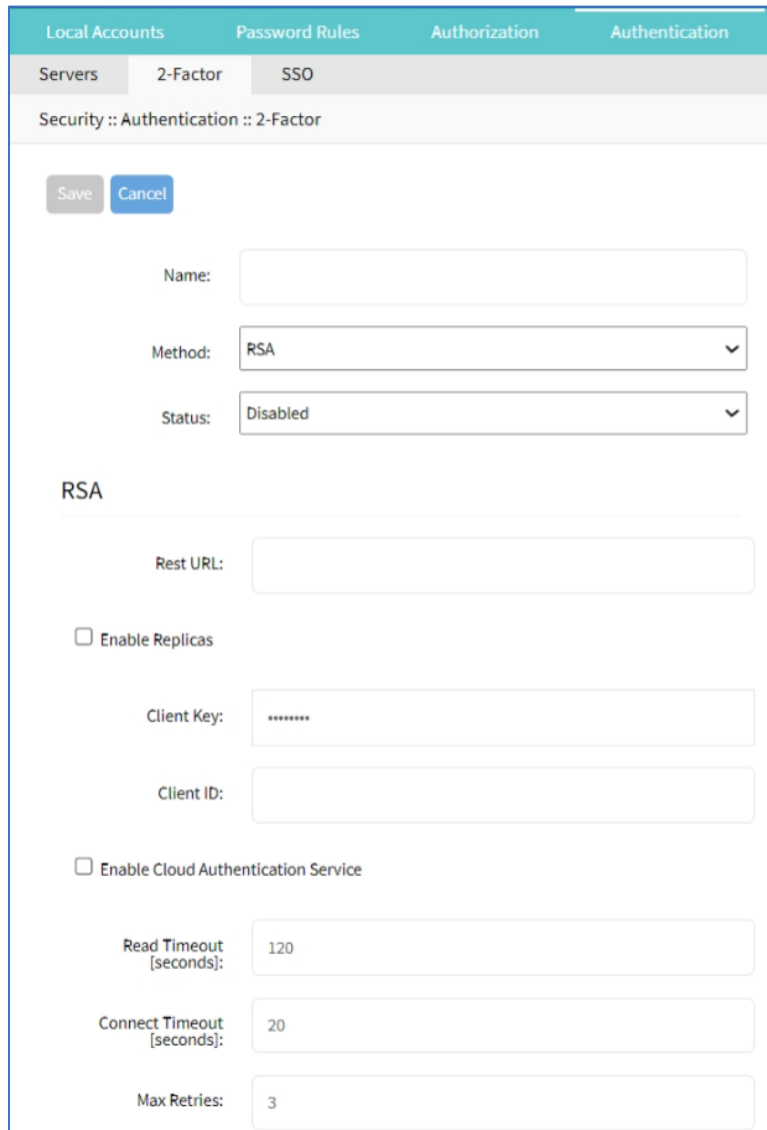

3. Enter **Name**.

4. On **Method** drop-down, select one (**RSA**).
5. On **Status** drop-down, select one (**Enabled, Disabled**).
6. In *RSA* menu:

Enter **Rest URL**.

Select **Enable Replicas** checkbox (expands dialog)

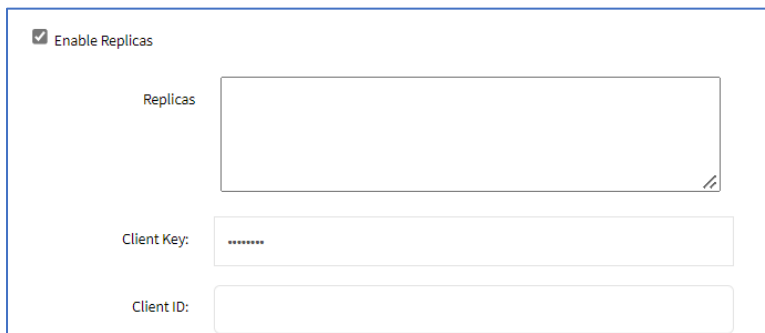

Enter **Replicas**.

Enter **Client Key**.

Enter **Client ID**.

Select **Enable Cloud Authentication Service** checkbox (expands dialog).

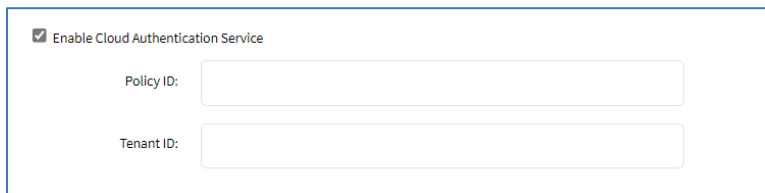

Enter **Policy ID**.

Enter **Tenant ID**.

Enter **Read Timeout [seconds]** (default: 120).

Enter **Connect Timeout [seconds]** (default: 20).

Enter **Max Retries** (default: 3).

7. Click **Save**.

## Configure RSA SecurID (2-Factor)

### Step 1 – Add SecurID (WebUI Procedure)

1. Go to *Security :: Authentication :: 2-Factor*.
2. Click **Add** (displays dialog)
3. Enter **Name** (name to identify the SecurID system, i.e., SecurID)

4. Enter **Rest URL** (URL to access the SecurID Authentication API – format: `https://5555/mfa/v1_1/authn`)
5. Select **Enable Replicas** (Rest Service URL to failover to the server (up to 15 replicas). One per line).  
**Client Key** (available through RSA Security Console. Copy/paste the **Access Key** from *SecurID Security Console*. The Access Key is also available at RSA SecurID Authentication API (under System Settings)  
**Client ID** (retrieve the Server Node name from the *Authentication Manager Contact List*.)
6. Select **Enable Cloud Authentication Service** checkbox (if enabled, two required fields display).  
**Policy ID** (access policy name configured in the ZPE Cloud Administration Console. Obtain this name from your Cloud Authentication Service Super Admin)  
**Tenant ID** (Tenant Id name created in the ZPE Cloud Administration Console. Obtain this name from your ZPE Cloud Authentication Service Super Admin)
7. Click **Save**.

### Step 2 – Set Certificate to access SecurID Server (WebUI Procedure)

1. If RSA server is through ZPE Cloud Authentication:  
Go to RSA SecurID Access and click the **Lock** icon (next to URL).  
Locate and click on the Certificate.  
On the pop-up dialog, click on the first/top certificate, and drag it to your desktop.  
Upload certificate to Nodegrid (certificate is automatically converted to the expected format).
2. If not via ZPE Cloud:  
Go the *RSA Operations Console*  
Download the Signing Root Certificate.  
Go to *Security :: Authentication :: 2-Factor*.  
Click the link representing the SecurID server (added above).  
Click **Certificate**.  
Select **Local Computer** checkbox.  
Click **Choose File** and select the file (i.e. RootCA.cer file).  
Click **Apply**,
3. Click **Save**.

## Edit 2-Factor Configuration

### WebUI Procedure

1. Go to *Security :: Authentication :: 2-Factor*.

2. In *Name* column, click the name to be updated (displays dialog).
3. Make changes, as needed.
4. Click **Save**.

## Delete 2-Factor Configuration

### WebUI Procedure

1. Go to *Security :: Authentication :: 2-Factor*.
2. Locate and select checkbox.
3. Click **Delete**.
4. On the confirmation pop-up dialog, click **OK**.

## Assign 2-factor to an Authentication Method

RSA SecurID 2-factor authentication can be added to any of the Nodegrid-supported authentication methods: Local, LDAP/AD, Radius, TACACS+, or Kerberos.

Nodegrid authenticates users following the order of the authentication servers, as configured. When a method succeeds (user authenticated), Nodegrid initiates the 2-factor authentication (if configured).

The user receives a request from RSA SecurID to provide the token code and PIN (according to the setup on the user's RSA Security Console). The process is applied on user login via Web Browser, SSH, Telnet or Console port.

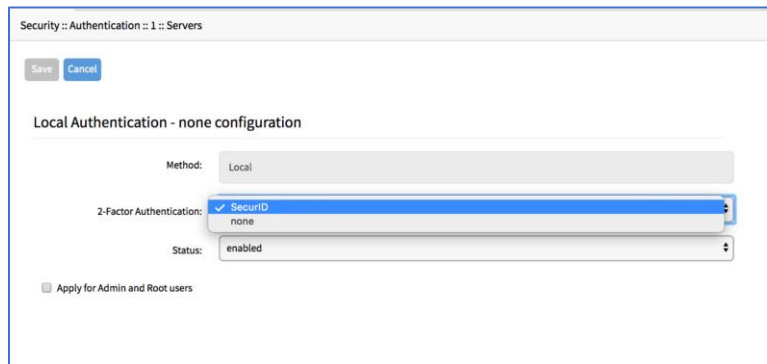

**NOTE:** For Local authentication method, 2-factor can be enforced or skipped. This allows local administrators to login without needing to configure counterpart users in the RSA Security Console.

## RSA Authenticate App

This applies only to ZPE Cloud Authentication Services.



1. Download the *RSA SecurID Authenticate* app.

2. Go to **RSA SecurID Access** and login.
3. Follow the steps to register the device.

## SSO sub-tab

With Single Sign-On (SSO), users authenticate once to gain access to multiple secured systems without resubmitting credentials. Nodegrid currently supports multiple identify providers.

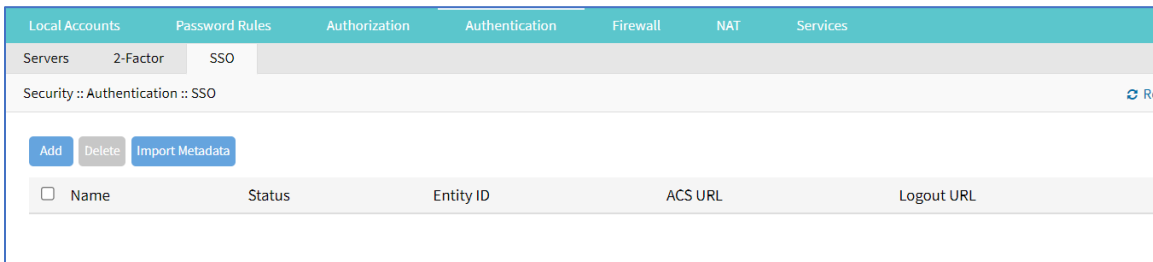

## Add SSO

### WebUI Procedure

1. Go to *Security :: Authentication :: SSO*.
2. Click **Add** (displays dialog).

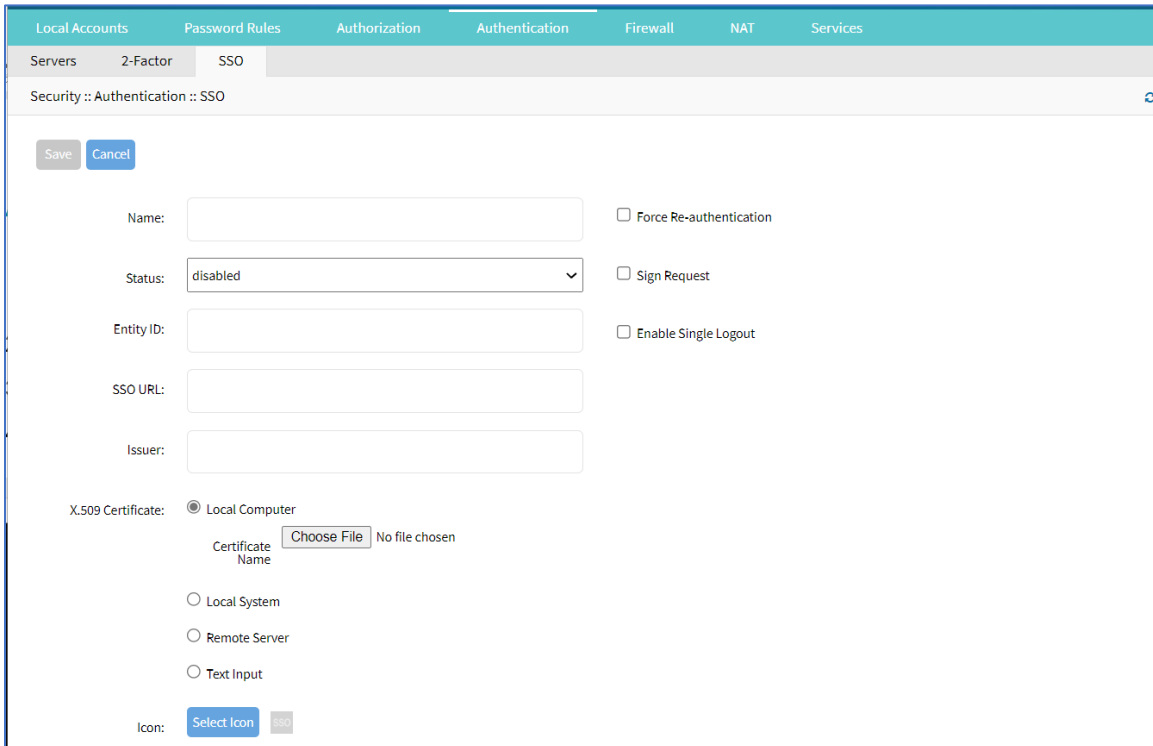

3. Enter **Name**.
4. On **Status** drop-down, select one (**Enabled, Disabled**).
5. Enter **Entity ID** (globally unique name).

6. Enter **SSO URL**.
7. Enter **Issuer**.
8. In *X-509 Certificate* menu, select one:

**Local Computer** radio button (expands dialog).

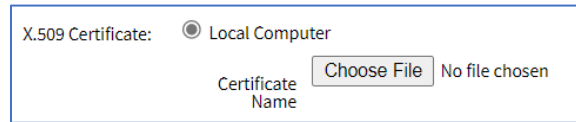

X.509 Certificate:  Local Computer

Certificate Name:  No file chosen

Click **Choose File**.

Locate and select file.

**Local System** radio button (expands dialog).

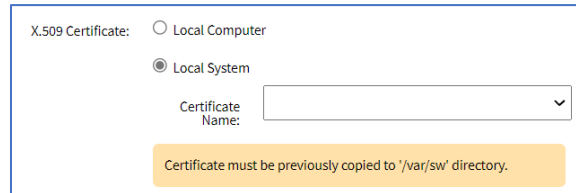

X.509 Certificate:  Local Computer

Local System

Certificate Name:

Certificate must be previously copied to '/var/sw' directory.

On **Certificate Name** drop-down, select one.

**Remote Server** radio button (expands dialog).

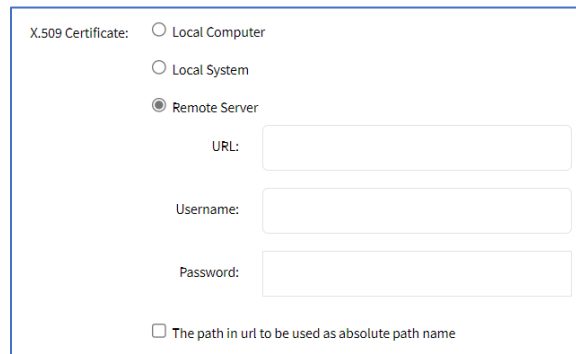

X.509 Certificate:  Local Computer

Local System

Remote Server

URL:

Username:

Password:

The path in url to be used as absolute path name

Enter **URL**.

Enter **Username**.

Enter **Password**.

(optional) Select **The path in url to be used as absolute path name** checkbox.

**Text Input** radio button (expands dialog).

In **Certificate** text box, enter details.

- 9. Select **Force Re-authentication** checkbox.
- 10. Select **Sign Request** checkbox.
- 11. Select **Enable Single Logout** checkbox. Enter **Logout URL**.

- 12. (optional) In **Icon**, click **Select Icon**. Click on a logo to set as 2-Factor icon.

- 13. Click **Save**.

The following fields are required to configure a successful SAML flow for each Identity Provider:

### SAML Requirements

Identity Provider (Idp)	Copy Fields from Nodegrid to IdP	Paste Fields from IDP to Nodegrid
Duo	Login URL Entity ID	SSO URL Entity ID Download Certificate
Okta	Single Sign On URL Audience URI (SP Entity ID)	Identity Provider SSO URL Identity Provider Issuer X.509 Certificate
G Suite	ACS URL Entity ID	SSO URL Entity ID Certificate



Identity Provider (Idp)	Copy Fields from Nodegrid to IdP	Paste Fields from IDP to Nodegrid
Ping	Entity ID ACS URL	Issuer Idpid <b>NOTE:</b> The idpid from Ping is used as the SSO URL field in Nodegrid: <a +the+idpid"="" href="https://sso.connect.pingidentity.com/sso/idp/SSO.saml2?idpid=">https://sso.connect.pingidentity.com/sso/idp/SSO.saml2?idpid= + the idpid</a>
ADFS	Entity ID (maps to Relying party trust identifier) ACS URL (maps to Trusted URL)	Entity ID (maps to Issuer on Nodegrid)

### IdP configuration fields:

*Entity ID* (globally unique name for the SP URL)

*ACS URL* (Assertion Consumer Service URL in which the Identity Provider redirects the user and sends the SAML assertion after its authentication process.)

*Attributes* (attributes that IdP sends back with the SAML assertion. SP can have more than one attribute, nameID is the most common.)

*SAML Signature Algorithm* (either SHA-1 or SHA-256. Used with X.509 certificate. Default: SHA-256.)

### SP configuration fields:

*X.509 Certificate* (certificate provided by the IdP to allow the SP to verify that the SAML assertion is from the IdP)

*Issuer URL/Entity ID* (unique identifier of the IdP)

*Single Sign On URL* (IdP endpoint that starts the authentication process)

*RelayState:* (optional) (deep linking for SAML for <ip>/direct/<device>/console)

For more information on SSO, please see <https://support.zpesystems.com/portal/kb/articles/single-sign-on-SSO>

## Import Metadata

### WebUI Procedure

1. Go to *Security :: Authentication :: SSO*.
2. Click **Import Metadata** (displays dialog).

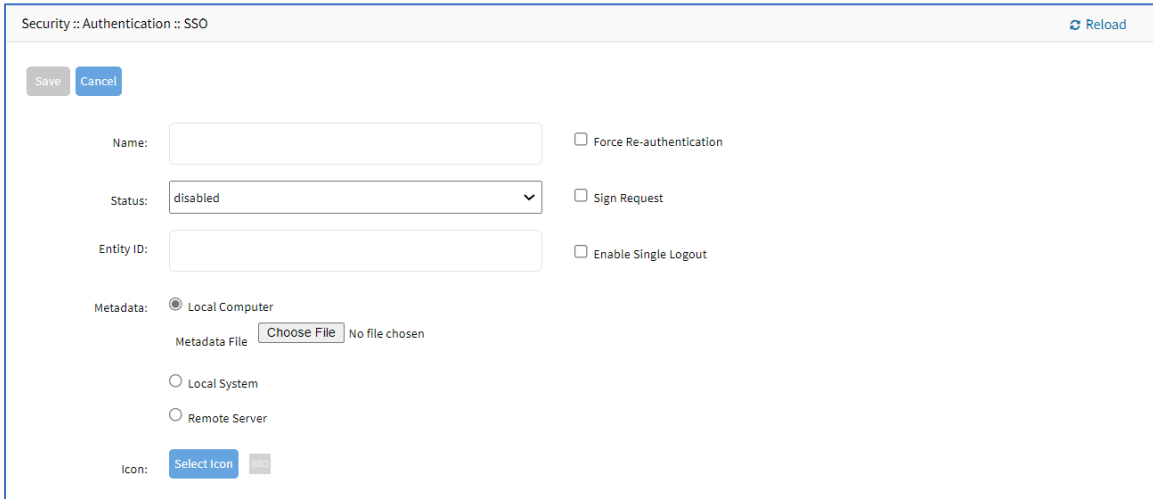

3. Enter **Name**.
4. On **Status** drop-down, select one (**Enabled, Disabled**).
5. Enter **Entity ID** (globally unique name).
6. In *Metadata* menu, select one:  
**Local Computer** radio button (expands dialog).

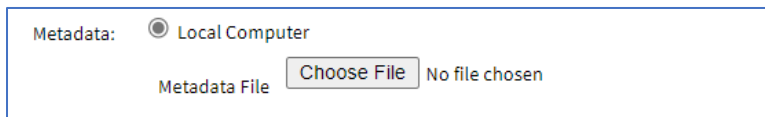

Click **Choose File**.

Locate and select file.

**Local System** radio button (expands dialog).

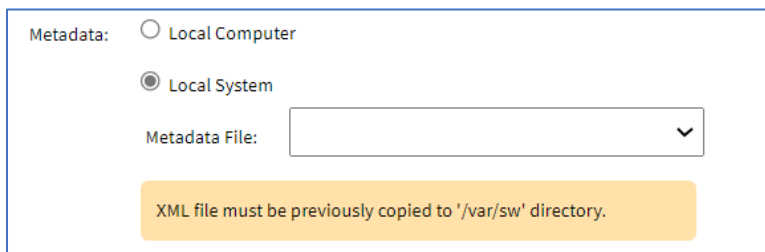

On **Metadata File** drop-down, select one.

**Remote Server** radio button (expands dialog).

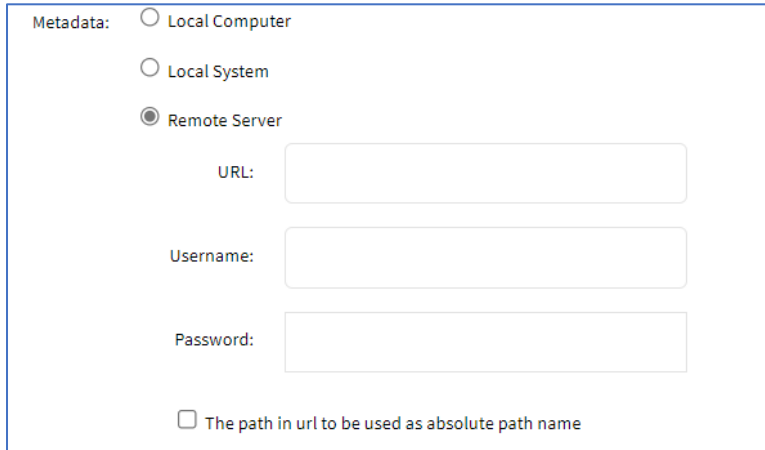

Enter **URL**.

Enter **Username**.

Enter **Password**.

(optional) Select **The path in url to be used as absolute path name** checkbox.

7. (optional) In **Icon**, click **Select Icon**. Click on a logo to set as 2-Factor icon.

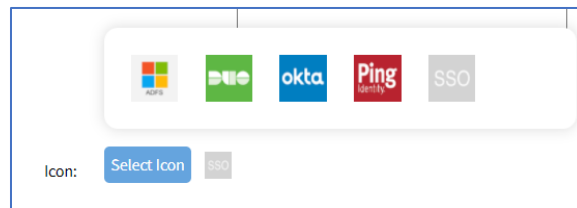

8. Select **Force Re-authentication** checkbox.

9. Select **Sign Request** checkbox.

10. Select **Enable Single Logout** checkbox.

11. Click **Save**.

## Firewall tab

When configured, the Nodegrid device functions as a Firewall. There are six built-in default chains (three for IPv4, three for IPv6). These accept packets (Output, Input, and Forward). As needed, additional user chains can be created. (Default chains cannot be deleted.)

Chain	Policy	Packets	Bytes	Type
<input type="checkbox"/> INPUT	ACCEPT	109305	25131106	IPv4
<input type="checkbox"/> FORWARD	ACCEPT	0	0	IPv4
<input type="checkbox"/> OUTPUT	ACCEPT	58355	22095940	IPv4
<input type="checkbox"/> INPUT	ACCEPT	0	0	IPv6
<input type="checkbox"/> FORWARD	ACCEPT	0	0	IPv6
<input type="checkbox"/> OUTPUT	ACCEPT	78972	5242168	IPv6

## Manage Chains

### Add a Chain

#### WebUI Procedure

1. Go to *Security :: Firewall*.
2. Click **Add** (displays dialog).

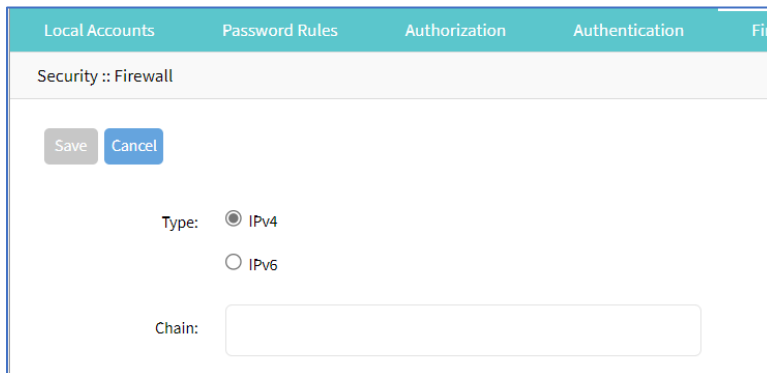

3. For **Type**, select one:
  - IPv4** radio button
  - IPv6** radio button
4. Enter **Chain** (name of this chain).
5. Click **Save**.

### Delete a Chain

#### WebUI Procedure

1. Go to *Security :: Firewall*.
2. Select checkbox next to name to be deleted.
3. Click **Delete**.
4. On confirmation pop-up dialog, click **OK**.

## Change Chain Policy

### WebUI Procedure

1. Go to *Security :: Firewall*.
2. In the *Chain* column, locate and click the name (displays dialog).

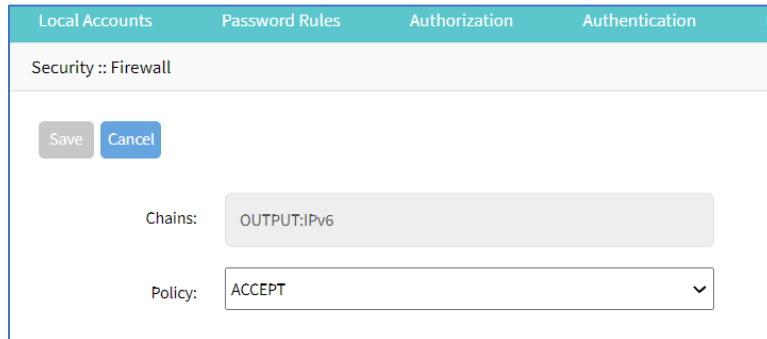

Local Accounts Password Rules Authorization Authentication Fi

Security :: Firewall

Save Cancel

Chains: OUTPUT:IPv6

Policy: ACCEPT

3. On **Policy** drop-down, select one (**ACCEPT**, **DROP**).
4. Click **Save**.

## Options to Manage a Chain

To manage chain functions/settings, click on the name in the *Chain* column (displays dialog).

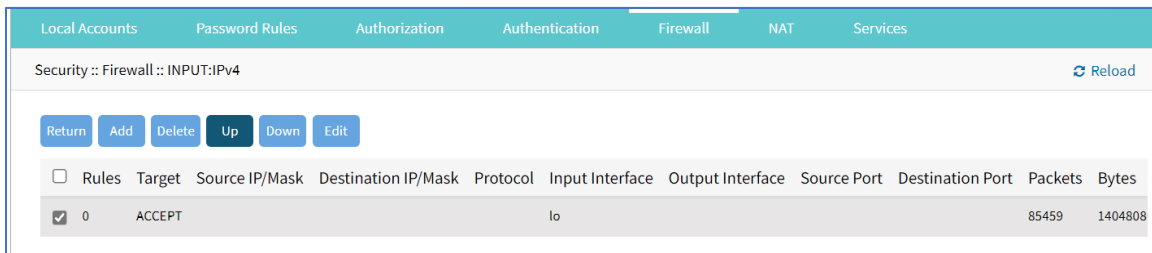

Local Accounts Password Rules Authorization Authentication Firewall NAT Services

Security :: Firewall :: INPUT:IPv4 [Reload](#)

Return Add Delete Up Down Edit

<input type="checkbox"/>	Rules	Target	Source IP/Mask	Destination IP/Mask	Protocol	Input Interface	Output Interface	Source Port	Destination Port	Packets	Bytes
<input checked="" type="checkbox"/>	0	ACCEPT				lo				85459	1404808

## Add Rule

### WebUI Procedure

1. Go to *Security :: Firewall*.
2. In the *Chain* column, locate and click on the name (displays dialog).
3. Click **Add** (displays dialog).

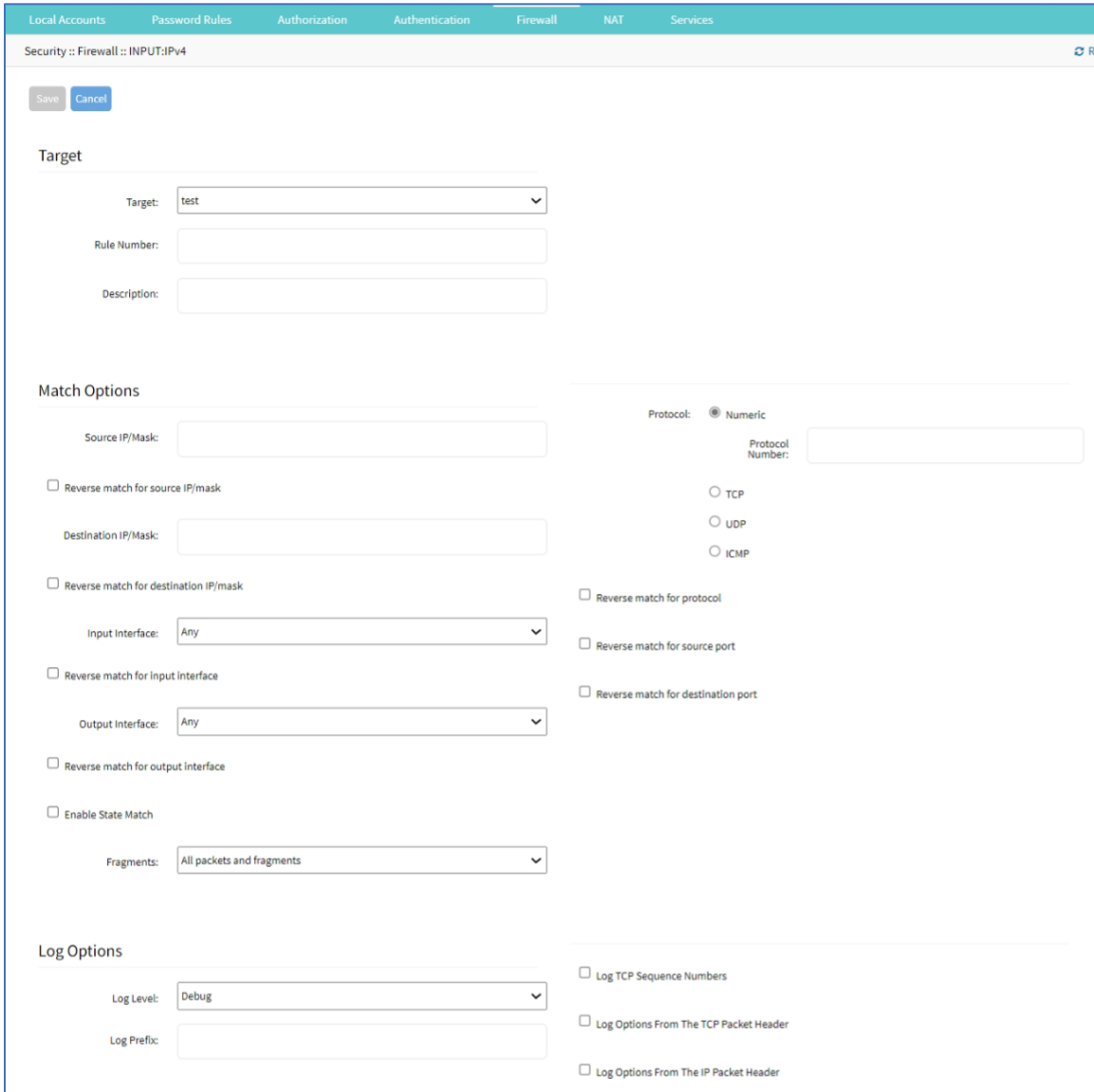

The screenshot shows the 'Security :: Firewall :: INPUT:IPv4' configuration page. It includes a 'Target' section with a dropdown menu set to 'test', and input fields for 'Rule Number' and 'Description'. The 'Match Options' section contains fields for 'Source IP/Mask', 'Destination IP/Mask', 'Input Interface' (set to 'Any'), and 'Output Interface' (set to 'Any'), each with a corresponding 'Reverse match' checkbox. It also includes 'Fragments' (set to 'All packets and fragments') and 'Enable State Match' (unchecked). The 'Log Options' section has a 'Log Level' dropdown set to 'Debug' and a 'Log Prefix' input field. On the right side, there are radio buttons for 'Protocol' (set to 'Numeric') and 'TCP', 'UDP', and 'ICMP', along with checkboxes for 'Reverse match for protocol', 'Reverse match for source port', 'Reverse match for destination port', 'Log TCP Sequence Numbers', 'Log Options From The TCP Packet Header', and 'Log Options From The IP Packet Header'.

4. In *Target* menu:

In **Target** drop-down, select one (**ACCEPT, DROP, REJECT, LOG, RETURN**).

Enter **Rule Number**.

Enter **Description**.

If **REJECT** selected, *Reject Options* menu displays:



The 'Reject Options' menu is shown with a 'Reject With' dropdown menu currently set to 'No Route'.

In **Reject With** drop-down, select one (**Network Unreachable, Host Unreachable, Port Unreachable, Protocol Unreachable, Network Prohibited, Host Prohibited, Administratively Prohibited, TCP Reset**).

5. In *Match Options* menu:

Enter **Source IP/Mask**.

Select **Reverse match for source IP/mask** checkbox.

Enter **Destination IP/Mask**.

Select **Reverse match for destination IP/mask** checkbox.

On **Input Interface** drop-down, select one (**Any, lo, eth0, eth1**).

Select **Reverse match for input interface** checkbox.

On **Output Interface** drop-down, select one (**Any, lo, eth0, eth1**).

Select **Reverse match for output interface** checkbox.

Select **Enable State Match** checkbox (displays options – one or more can be selected):

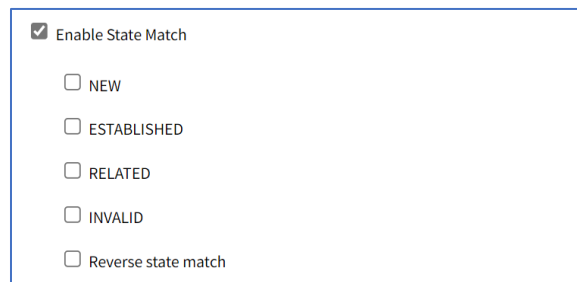

**NEW** checkbox.

**ESTABLISHED** checkbox.

**RELATED** checkbox.

**INVALID** checkbox.

**Reverse state match** checkbox

On **Fragments** drop-down, select one (**All packets and fragments, Unfragmented packets and 1st packets, 2nd and further packets**).

In *Protocol* menu, select one:

**Numeric** radio button (expands dialog).

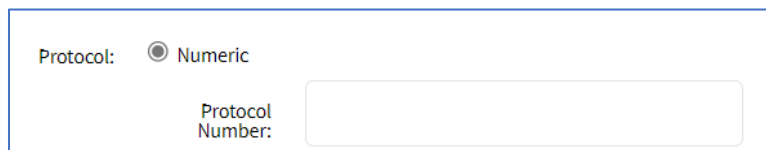

Enter **Protocol Number**.

**TCP** radio button (expands dialog).

Protocol:  Numeric

TCP

Source Port:

Destination Port:

TCP Flag SYN:  ▼

TCP Flag ACK:  ▼

TCP Flag FIN:  ▼

TCP Flag RST:  ▼

TCP Flag URG:  ▼

TCP Flag PSH:  ▼

Reverse match for TCP flags

UDP

ICMP

Enter **Source Port**.

Enter **Destination Port**.

On **TCP Flag SYN** drop-down, select one (**Any, Set, Unset**).

On **TCP Flag ACK** drop-down, select one (**Any, Set, Unset**).

On **TCP Flag FIN** drop-down, select one (**Any, Set, Unset**).

On **TCP Flag RST** drop-down, select one (**Any, Set, Unset**).

On **TCP Flag URG** drop-down, select one (**Any, Set, Unset**).

On **TCP Flag PSH** drop-down, select one (**Any, Set, Unset**).

Select **Reverse Match for TCP Flags** checkbox.



**UDP** radio button (expands dialog).

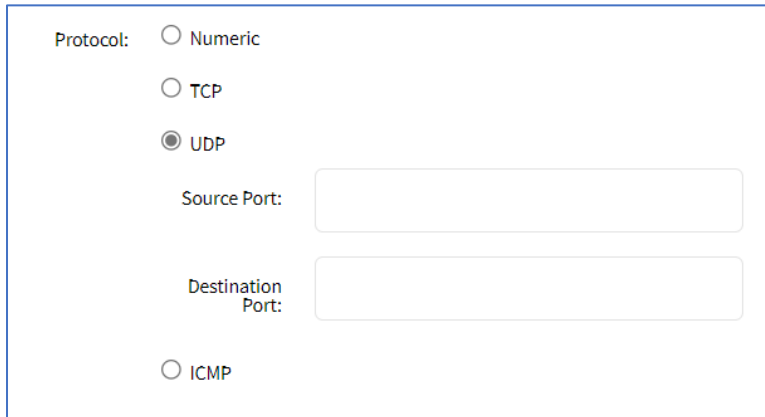

Protocol:  Numeric  
 TCP  
 UDP  
 ICMP

Source Port:

Destination Port:

Enter **Source Port**.

Enter **Destination Port**.

**ICMP** radio button (expands dialog).

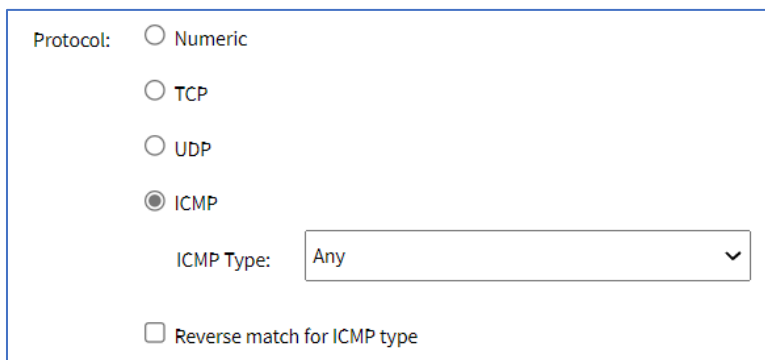

Protocol:  Numeric  
 TCP  
 UDP  
 ICMP

ICMP Type:

Reverse match for ICMP type

On **ICMP Type** drop-down, select one (Any, Echo Reply, Destination Unreachable, Network Unreachable, Host Unreachable, Protocol Unreachable, Port Unreachable, Fragmentation Needed, Source Route Failed, Network Unknown, Host Unknown, Network Prohibited, Host Prohibited, TOS Network Unreachable, TOS Host Unreachable, Communication Prohibited, Host Precedence Violation, Precedence Cutoff, Source Quench, Redirect, Network Redirect, Host Redirect, TOS Network Redirect, TOS Host Redirect, Echo Request, Router Advertisement, Router Solicitation, Time Exceeded, TTL Zero During Transit, TTL Zero During Reassembly, Parameter Problem, Bad IP Header, Required Option Missing, Timestamp Request, Timestamp Reply, Address Mask Request, Address Mask Reply)

Select **Reverse match for ICMP type** checkbox.

Select **Reverse match for protocol** checkbox.

Select **Reverse match for source port** checkbox.

Select **Reverse match for destination port** checkbox.

6. In *Log Options* menu:

On **Log Level** drop-down, select one (**Debug**, **Info**, **Notice**, **Warning**, **Error**, **Critical**, **Alert**, **Emergency**).

Enter **Log Prefix**.

Select **Log TCP Sequence Numbers** checkbox.

Select **Log Options from the TCP Packet Header** checkbox.

Select **Log Options from the IP Packet Header** checkbox.

7. Click **Save**.

## Edit Chain

### WebUI Procedure

1. Go to *Security :: Firewall*.
2. In the *Chain* column, locate and click on the checkbox.
3. Click **Edit** (displays dialog).
4. Make changes, as needed.
5. Click **Save**.

## Delete Chain

### WebUI Procedure

1. Go to *Security :: Firewall*.
2. In the *Chain* column, locate and select checkbox on the name.
3. Click **Delete**.
4. On the confirmation pop-up dialog, click **OK**.

## Move Chain Up/Down

### WebUI Procedure

1. Go to *Security :: Firewall*.
2. In the *Chain* column, locate and select checkbox on the name.
3. Click **Up** to move up.
4. Click **Down** to move down.

## NAT tab

There are eight built-in default chains (cannot be deleted): IPv4 with four, IPv6 with four. These accept Pre-routing, Output, Input, and Post-routing packets. Rules can be created for each chain.

Chain	Policy	Packets	Bytes	Type
<input type="checkbox"/> Chain				
<input type="checkbox"/> PREROUTING	ACCEPT	61740	7793280	IPv4
<input type="checkbox"/> INPUT	ACCEPT	61653	7785918	IPv4
<input type="checkbox"/> OUTPUT	ACCEPT	455097	30146854	IPv4
<input type="checkbox"/> POSTROUTING	ACCEPT	455097	30146854	IPv4
<input type="checkbox"/> PREROUTING	ACCEPT	219	33655	IPv6
<input type="checkbox"/> INPUT	ACCEPT	0	0	IPv6
<input type="checkbox"/> OUTPUT	ACCEPT	44	3168	IPv6
<input type="checkbox"/> POSTROUTING	ACCEPT	44	3168	IPv6

## Manage Chains

### Add a Chain

#### WebUI Procedure

1. Go to *Security :: NAT*.
2. Click **Add** (displays dialog).

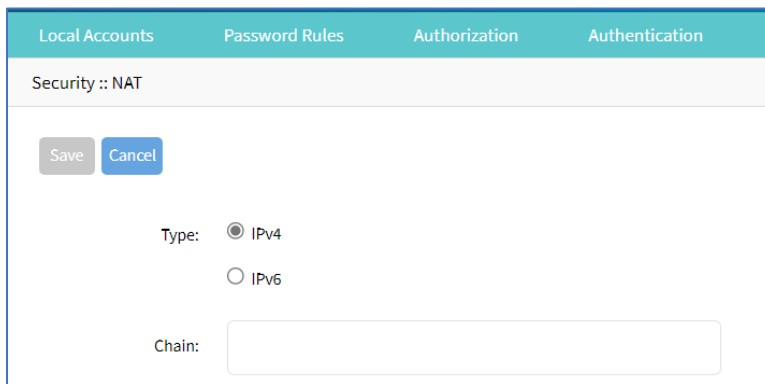

3. For **Type**, select one
  - IPv4** radio button
  - IPv6** radio button
4. Enter **Chain** (name of this chain).
5. Click **Save**.

### Delete a Chain

#### WebUI Procedure

1. Go to *Security :: NAT*.
2. Select checkbox next to name to be deleted.

3. Click **Delete**.
4. On confirmation pop-up dialog, click **OK**.

## Change Chain Policy

### WebUI Procedure

1. Go to *Security :: NAT*.
2. In the *Chain* column, locate and click the name (displays dialog).

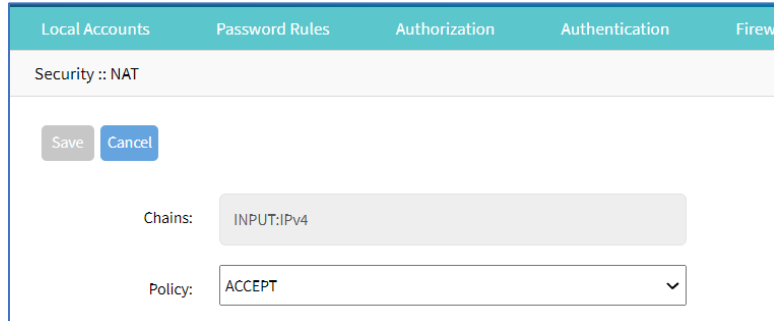

3. On **Policy** drop-down, select one (**ACCEPT**, **DROP**).
4. Click **Save**.

## Manage Chain Settings

To manage chain functions/settings, click on the name in the *Chain* column (displays dialog).

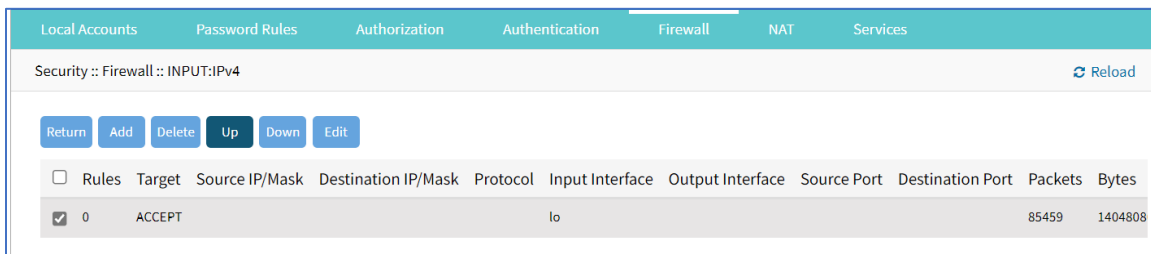

<input type="checkbox"/>	Rules	Target	Source IP/Mask	Destination IP/Mask	Protocol	Input Interface	Output Interface	Source Port	Destination Port	Packets	Bytes
<input checked="" type="checkbox"/>	0	ACCEPT				lo				85459	1404808

## Add Chain Setting (all Type selections)

### WebUI Procedure

1. Go to *Security :: NAT*.
2. In the *Chain* column, locate and click on the name (displays dialog).
3. Click **Add** (displays dialog).

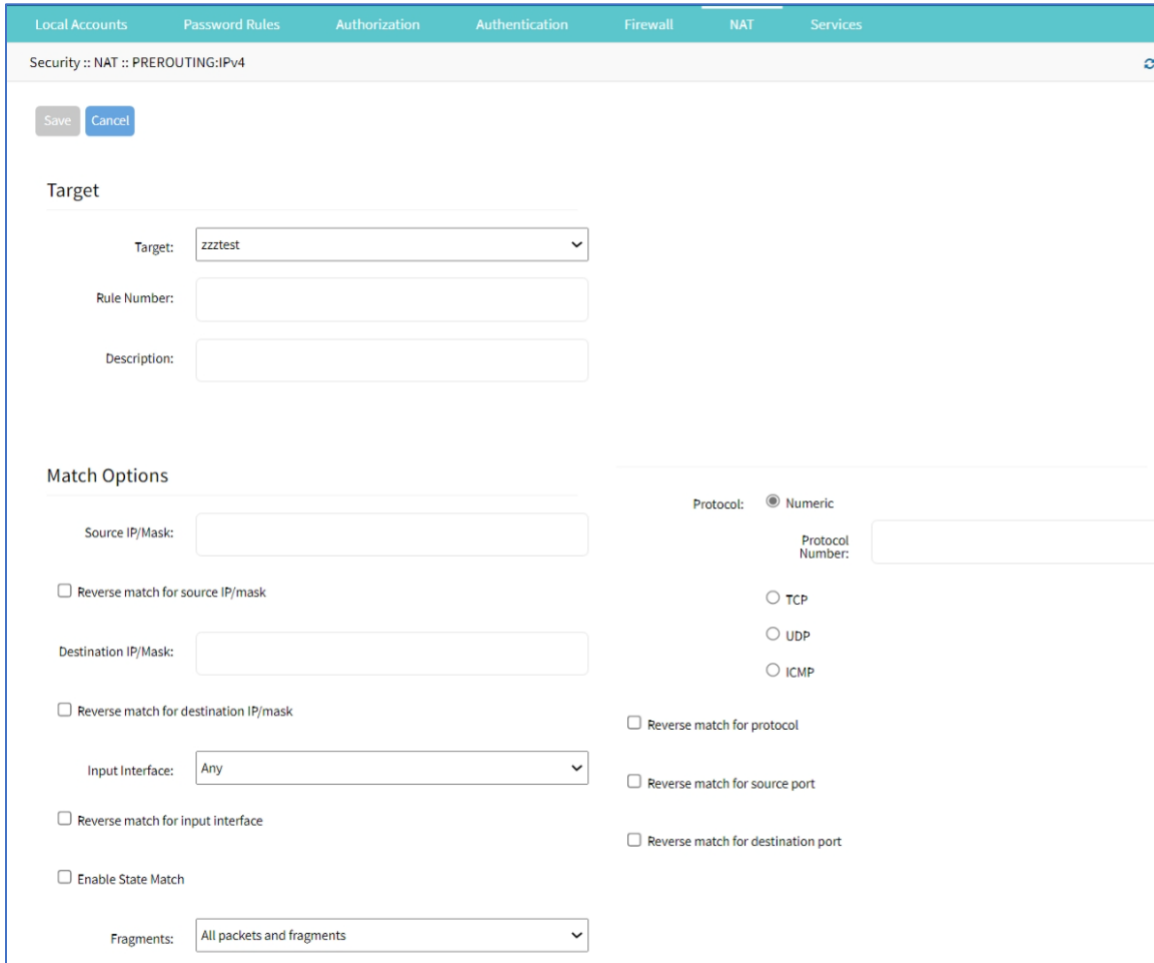

The screenshot shows the NAT configuration page for 'Security :: NAT :: PREROUTING:IPv4'. It features a 'Target' section with a dropdown menu set to 'zzztest', and empty fields for 'Rule Number' and 'Description'. The 'Match Options' section includes fields for 'Source IP/Mask' and 'Destination IP/Mask', both with 'Reverse match for source IP/mask' and 'Reverse match for destination IP/mask' checkboxes. The 'Input Interface' is set to 'Any' with a 'Reverse match for input interface' checkbox. There are also checkboxes for 'Enable State Match' and 'Fragments' (set to 'All packets and fragments'). On the right, the 'Protocol' is set to 'Numeric' with a 'Protocol Number' field, and radio buttons for 'TCP', 'UDP', and 'ICMP'. 'Reverse match for protocol', 'Reverse match for source port', and 'Reverse match for destination port' checkboxes are also present.

4. In *Target* menu:

In **Target** drop-down, select one (**ACCEPT, DNAT, REDIRECT, LOG, RETURN**).

Enter **Rule Number**.

Enter **Description**.

5. In *Match Options* menu:

Enter **Source IP/Mask**.

Select **Reverse match for source IP/mask** checkbox.

Enter **Destination IP/Mask**.

Select **Reverse match for destination IP/mask** checkbox.

On **Input Interface** drop-down, select one (**Any, lo, eth0, eth1**).

Select **Reverse match for input interface** checkbox.

Select **Enable State Match** checkbox (displays options – one or more can be selected):

**NEW** checkbox.

**ESTABLISHED** checkbox.

**RELATED** checkbox.

**INVALID** checkbox.

**SNAT** checkbox.

**DNAT** checkbox.

**Reverse state match** checkbox

On **Fragments** drop-down, select one (**All packets and fragments**, **Unfragmented packets and 1st packets**, **2nd and further packets**).

(Type selection: **DNAT**) Enter **To Destination**.

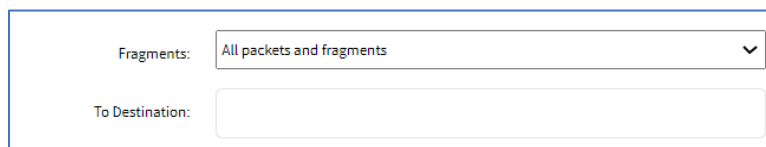

The screenshot shows a form with two fields. The first field is a drop-down menu labeled "Fragments:" with the text "All packets and fragments" and a downward arrow. The second field is a text input box labeled "To Destination:".

In *Protocol* menu, select one:

**Numeric** radio button (expands dialog).

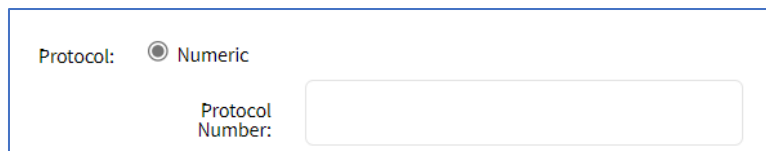

The screenshot shows a form with two elements. The first is a radio button labeled "Protocol:" with the text "Numeric" next to it. The second is a text input box labeled "Protocol Number:".

Enter **Protocol Number**.

**TCP** radio button (expands dialog).

Protocol:  Numeric  
 **TCP**

Source Port:

Destination Port:

To Ports:

TCP Flag SYN:  ▼

TCP Flag ACK:  ▼

TCP Flag FIN:  ▼

TCP Flag RST:  ▼

TCP Flag URG:  ▼

TCP Flag PSH:  ▼

Reverse match for TCP flags

Enter **Source Port**.

Enter **Destination Port**.

Enter **To Ports**

On **TCP Flag SYN** drop-down, select one (**Any, Set, Unset**).

On **TCP Flag ACK** drop-down, select one (**Any, Set, Unset**).

On **TCP Flag FIN** drop-down, select one (**Any, Set, Unset**).

On **TCP Flag RST** drop-down, select one (**Any, Set, Unset**).

On **TCP Flag URG** drop-down, select one (**Any, Set, Unset**).

On **TCP Flag PSH** drop-down, select one (**Any, Set, Unset**).

Select **Reverse Match for TCP Flags** checkbox.

**UDP** radio button (expands dialog).

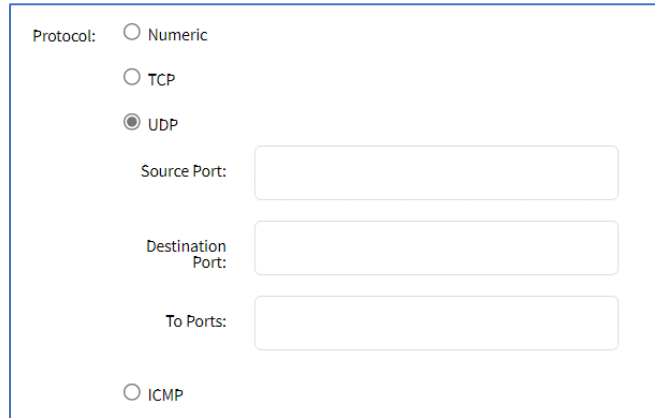

Enter **Source Port**.

Enter **Destination Port**.

Enter **To Ports**.

**ICMP** radio button (expands dialog).

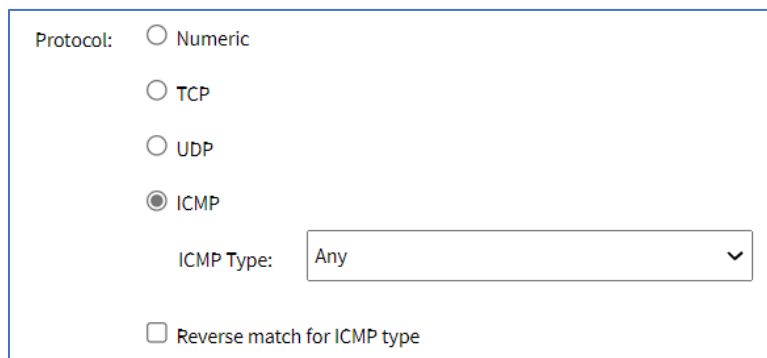

On **ICMP Type** drop-down, select one (

Select **Reverse match for ICMP type** checkbox.

Select **Reverse match for protocol** checkbox.

Select **Reverse match for source port** checkbox.

Select **Reverse match for destination port** checkbox.

6. In *Log Options* menu (only if **Type** selection: **LOG**).

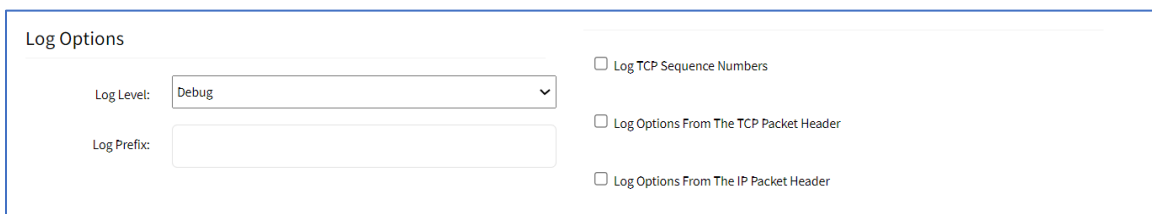

On **Log Level** drop-down, select one (**Debug, Info, Notice, Warning, Error, Critical, Alert, Emergency**).



Enter **Log Profile** (name of this profile).

Select **Log TCP Sequence Numbers** checkbox.

Select **Log Options From The TCP Packet Header** checkbox.

Select **Log Options From The IP Packet Header** checkbox.

7. Click **Save**.

## Edit Chain Setting

### WebUI Procedure

1. Go to *Security :: NAT*.
2. In the *Chain* column, locate and click on the checkbox.
3. Click **Edit** (displays dialog).
4. Make changes, as needed.
5. Click **Save**.

## Delete Chain Setting

### WebUI Procedure

1. Go to *Security :: NAT*.
2. In the *Chain* column, locate and select checkbox next to name.
3. Click **Delete**.
4. On the confirmation pop-up dialog, click **OK**.

## Move Up/Down

### WebUI Procedure

1. Go to *Security :: NAT*.
2. In the *Chain* column, locate and select checkbox on the name.
3. Click **Up** to move up.
4. Click **Down** to move down.

## Services tab

The device's security level is configured here. This includes active service settings for ZPE Cloud, managed devices, intrusion prevention, SSH, web service settings, and cryptographic protocols.

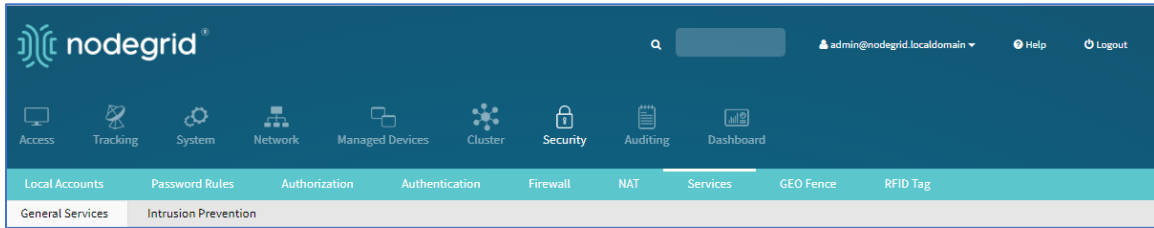

## General Services sub-tab

General security service settings are configured on this page. Because of this complexity, it is recommended to prepare a document that defines how the company security requirements are implemented with the device security settings.

Local Accounts Password Rules Authorization Authentication Firewall NAT Services GEO Fence

General Services Intrusion Prevention

Security :: Services :: General Services Reload

**Save**

### ZPE Cloud

- Enable ZPE Cloud
  - ZPE Cloud URL:
  - Enable Remote Access
  - Enable File Protection
- System Profile:

### Active Services

- Enable detection of USB devices
- Enable RPC
- Enable gRPC
- Enable FTP Service
- Enable S/NMP Service
- Enable Teinet Service to Nodegrid
- Enable Teinet Service to Managed Devices
- Enable ICMP echo reply
- Enable ICMP secure redirects
- Enable USB over IP
- Enable Elasticsearch
  - Enable Kibana
- Enable Telegraf

### Enable Virtualization Services

- Enable Docker
- Enable Qemu/KVM
- Enable VMware Manager
  - Cluster TCP Port:
- Enable Automatic Cluster Enrollment
  - Search Engine TCP Port:
  - Enable Search Engine High Level Cipher Suite
- Enable VM Serial access
  - VM Serial Port:
  - vMotion timeout (seconds):
- Enable Zero Touch Provisioning
- Enable Bluetooth
  - Display name:
  - Enable Bluetooth Discoverable mode
- Enable PXE (Preboot execution Environment)
- Block host with multiple authentication fails
- Allow root console access

### Managed Devices

- Device access enforced via user group authorization
- Enable Autodiscovery
  - DHCP lease controlled by autodiscovery rules

### SSH

- SSH allow root access
- SSH TCP Port:
- SSH Ciphers:
- SSH MACs:
- SSH KeyAlgorithms:

### Web Service

- Enable HTTP access
  - HTTP Port:
- Enable HTTPS access
  - HTTPS Port:
- Redirect HTTP to HTTPS

### Cryptographic Protocols

- TLSv1.3
- TLSv1.2
- TLSv1.1
- TLSv1
- Cipher Suite Level:
  - High
  - Medium
  - Low
  - Custom

Changes affecting HTTP and HTTPS services will terminate all HTTP sessions

## Configure General Services

### WebUI Procedure

1. Go to *Security :: Services :: General Services*.

2. In *ZPE Cloud* menu (cloud-based management platform for Nodegrid products):

Select **Enable ZPE Cloud** checkbox (Nodegrid NSR, GSR, BSR, LSR, HSR - default: enabled. Nodegrid Serial Console - default: disabled).

Confirm **ZPE Cloud URL** (read-only).

Select **Enable Remote Access** checkbox.

(optional) Select **Enable File Protection** checkbox (If enabled, file transfer requires authentication hash based on this password to validate file integrity and origin – default: disabled).

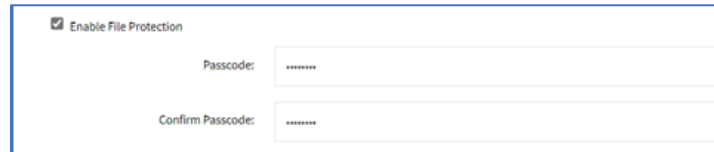

3. In *Active Services* menu (select all that apply):

Select **Enable detection of USB devices** checkbox.

Select **Enable RPC** checkbox.

Select **Enable gRPC** checkbox. Enter **gRPC Port**.

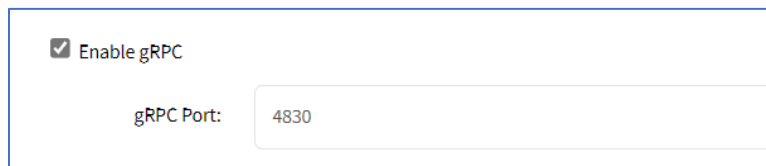

Select **Enable FTP Service** checkbox.

Select **Enable SNMP Service** checkbox (default: enabled).

Select **Enable Telnet Service to Nodegrid** checkbox (expands dialog).

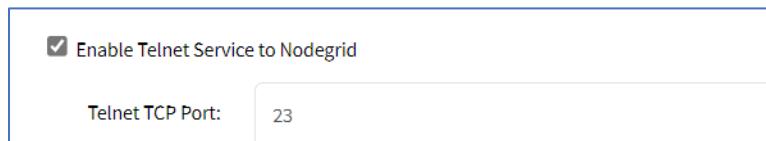

Enter **Telnet TCP Port** (default: 23).

Select **Enable Telnet Service to Managed Devices** checkbox.

Select **Enable ICMP echo reply** checkbox.

Select **Enable ICMP secure redirects** checkbox.

Select **Enable USB over IP** checkbox.

Select **Enable Elasticsearch** checkbox (expands dialog).



Select **Enable Kibana** checkbox.

Select **Enable Telegraf** checkbox

Select **Enable Services Status Page** (<NG URL>/services/status) used to determine functioning services

Select **Enable reboot on Services Status Page** checkbox (allows device reboot on the /services/status page)

4. In *Enable Virtualization Services* menu (select all that apply):

Select **Enable Docker** checkbox

Select **Enable Qemu/KVM** checkbox

Select **Enable VMware Manager** checkbox

Enter **Cluster TCP Port** (default: 9966)

Select **Enable Automatic Cluster Enrollment** checkbox

Enter **Search Engine TCP Port** (default: 9300)

Select **Enable Search Engine High Level Cipher Suite** checkbox

Select **Enable VM Serial access** checkbox (default: enabled)

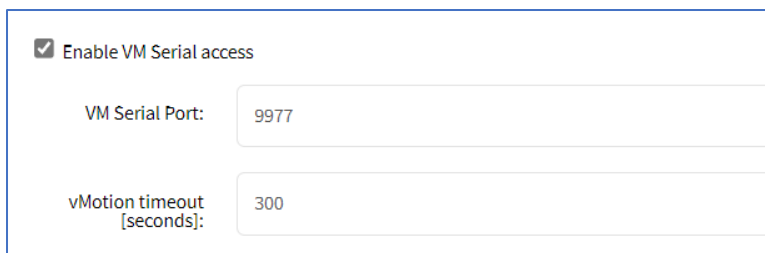

Enter **VM Serial Port** (default: 9977)

Enter **vMotion timeout [seconds]** (default: 300)

Select **Enable Zero Touch Provisioning** checkbox (default: enabled)

Select **Enable Bluetooth** checkbox

Enable Bluetooth

Display name:

Enable Bluetooth Discoverable mode

**NOTE:** (default: enabled) Completely enables/disables Bluetooth on the device. When enabled, tethers the network connection via Bluetooth to the device without any configuration. This tethers the network connection via Bluetooth to be the first device deployed on the network. This temporary connection reaches ZPE Cloud to download its full configuration.

Enter **Display name**.

**NOTE:** Name displayed on other devices paired with this device via Bluetooth (default format: <ProductName\_SerialNumber>).

Select **Enable Bluetooth Discoverable mode** checkbox.

**NOTE:** (default: enabled) Enables discovery and pairing this device to an external device. , This tethers the network connection via Bluetooth to be the first device deployed on the network. This temporary connection reaches ZPE Cloud to download its full configuration. When a connection is established to a trusted device, this discoverable mode can be disabled to ensure other devices cannot pair with this device.

Select **Enable PXE (Preboot eXecution Environment)** checkbox (default: enabled).

Select **Block host with multiple authentication fails** checkbox.

Block host with multiple authentication fails

Period Host will stay blocked (min):

Timeframe to monitor authentication fails (min):

Number of authentication fails to block host:

Whitelisted IP Addresses:

Enter **Period Host will stay blocked (min)** (default: 10).

Enter **Timeframe to monitor authentication fails (min)** (default: 10).

Enter **Number of authentication fails to block host** (default: 5).

Enter **Whitelisted IP Addresses** (comma-separated).

Select **Allow root console access** checkbox.

5. In *Managed Devices* menu (select all that apply):

Select **Device access enforced via user group authorization** checkbox (If enabled, users can only access devices listed in user's authorization groups. If not enabled, all enrolled devices are available.).

Select **Enable Autodiscovery** checkbox. Select **DHCP lease controlled by autodiscovery rules** checkbox (default: auto-selected).

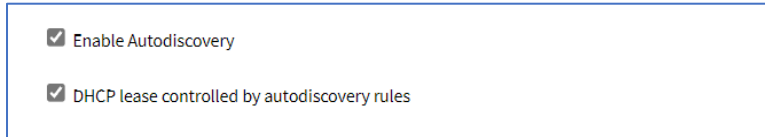

A screenshot of a configuration panel with a blue border. It contains two checked checkboxes: "Enable Autodiscovery" and "DHCP lease controlled by autodiscovery rules".

6. In *SSH* menu:

Select **SSH allow root access** checkbox (default: enabled).

Enter **SSH TCP Port** (default: 22).

Enter **SSH Ciphers** (comma-separated) (default: blank).

Enter **SSH MACs** (comma-separated) (default: blank).

Enter **SSH KexAlgorithms** (comma-separated) (default: blank).

7. In *Web Service* menu:

Select **Enable HTTP access** checkbox (default: enabled).

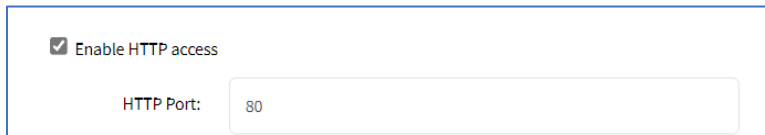

A screenshot of a configuration panel with a blue border. It contains a checked checkbox "Enable HTTP access" and a text input field labeled "HTTP Port:" with the value "80".

Enter **HTTP Port** (default: 80).

Select **Enable HTTPS access** checkbox (default: enabled).

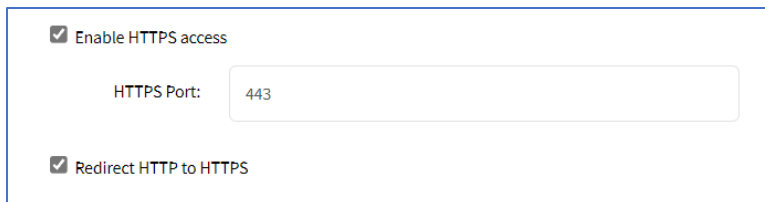

A screenshot of a configuration panel with a blue border. It contains a checked checkbox "Enable HTTPS access", a text input field labeled "HTTPS Port:" with the value "443", and a checked checkbox "Redirect HTTP to HTTPS".

Enter **HTTP Port** (default: 443)

Select **Redirect HTTP to HTTPS** checkbox (default: enabled).

Select **Enable HTTP/S File Repository** checkbox (default: disabled). When enabled, provides public access of files uploaded in the File Manager/datastore folder (to access the file publicly, use `https://<Nodegrid URL>/datastore/<filename.ext>`). For security reasons, full path of the file is required. In addition, "list", "edit", and "post" commands are disabled.

8. In *FRR* menu:

Select **Enable BGP** checkbox.

Select **Enable OSPFv2** checkbox.

Select **Enable OSPFv3** checkbox.

Select **Enable RIP** checkbox.

Select **Enable VRRP** checkbox.

9. In *Cryptographic Protocols* menu:

Select **TLSv1.3** checkbox (default: enabled).

Select **TLSv1.2** checkbox (default: enabled).

Select **TLSv1.1** checkbox (default: enabled).

Select **TLSv1** checkbox (default: disabled).

In *Cipher Suite Level* menu, select one:

**High** radio button.

**Medium** radio button (default).

**Low** radio button.

**Custom** radio button (expands dialog).

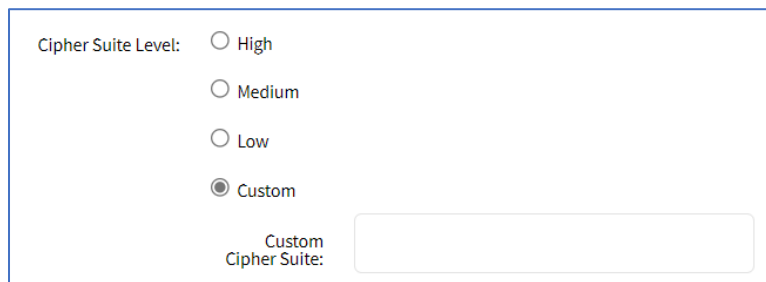

Cipher Suite Level:  High  
 Medium  
 Low  
 Custom  
 Custom Cipher Suite:

Enter **Custom Cipher Suite**.

10. Click **Save**.

ZPE Cloud ensures all deployment activity is done at the device location.

## CLI – Enable ZPE Cloud

### CLI Procedure

1. Go to *Access :: Table*.

2. Locate the device and click **Console**.

3. On the CLI window, enter:

```
shell sudo su -
zpe_cloud_enroll
```

4. Enter Customer Code and Enrollment Key.



**NOTE:** To locate Customer Code and Enrollment Key, log into ZPE Cloud account and go to *Settings :: Enrollment*. (The **Enable Device Enrollment** checkbox must be enabled.)

5. A confirmation is sent when the enrollment succeeds.

#### Example 1 – select options from menu.

```
root@ZPECloudNSR2:~# zpe_cloud_enroll -h
Usage: zpe_cloud_enroll [options]
ZPE Cloud Enrollment

Options:
  -v, --version          Displays version information.
  -h, --help            Displays this help.
  -c <customer-code>   ZPE Cloud customer code to enroll device.
  -k <enrollment-key> ZPE Cloud customer enrollment key.
  -r                    Read customer enrollment key from barcode.
```

**Example 2 – no arguments included.** If no arguments provided, Customer Code and Enrollment Key is requested.

```
root@ZPECloudNSR2:~# zpe_cloud_enroll
Enter your customer code: 2
Customer Code: "2"
Enter your enrollment key: example_key
```

**Example 3 – with arguments.** Customer code (-c) and enrollment key (-k) are provided as the arguments.

```
root@ZPECloudNSR2:~# zpe_cloud_enroll -c 23665442 -k example_key
```

When ZPE Cloud is enabled on the device, it is accessible on the ZPE Cloud application.

### ***Intrusion Prevention sub-tab***

This configures intrusion prevention settings.

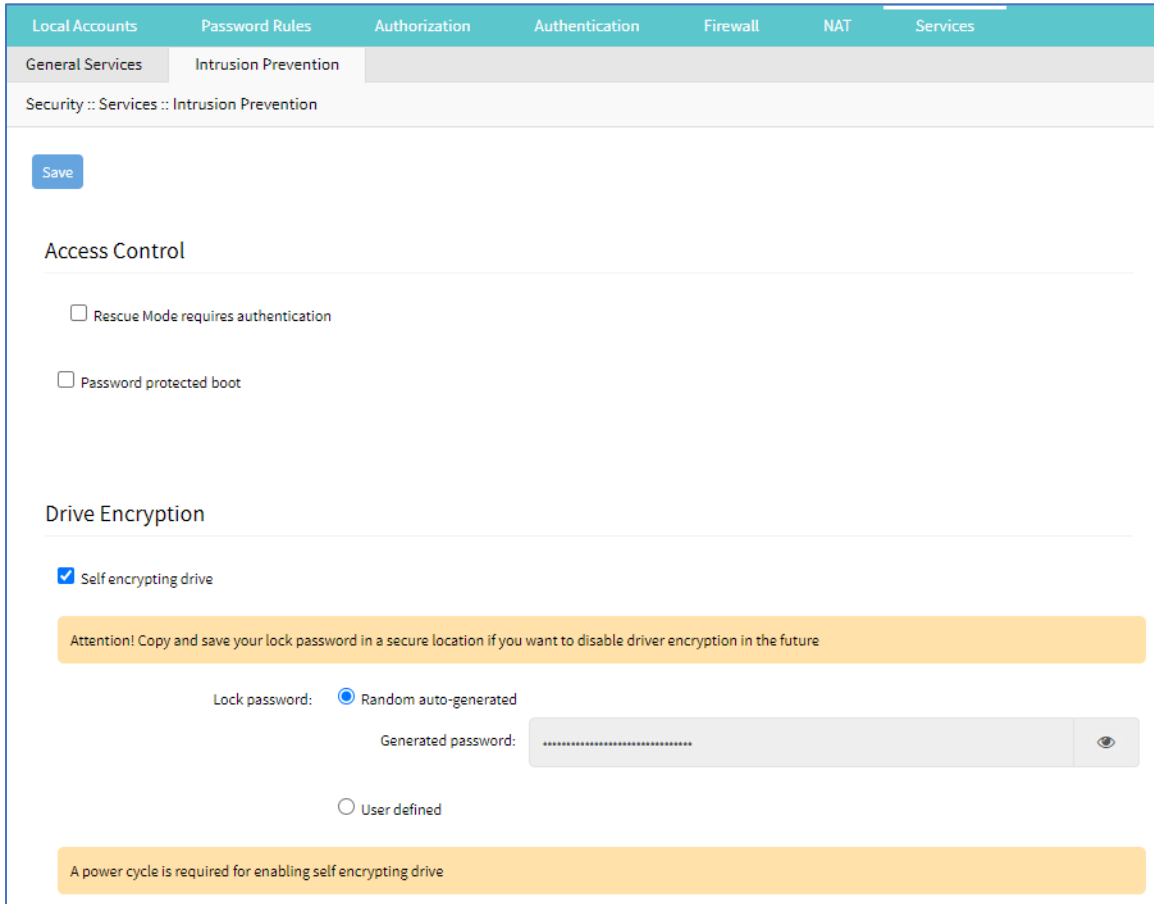

## Configure Intrusion Prevention

### WebUI Procedure

1. Go to *Security :: Services :: Intrusion Prevention*.

2. In *Access Control* menu:

Select **Rescue Mode requires authentication** checkbox.

Select **Password protected boot** checkbox (password required to reboot).

3. In *Drive Encryption* menu:

**NOTE:** This menu is only available if the drive is OPAL 2 compliant.

Select **Self encrypting drive** checkbox. If enabled, the device must be restarted for the change to take effect.

In *Lock Password* menu, select one:

**Random auto-generated** radio button (save password in a secure location - cannot be recovered if lost).

**User defined** radio button. Enter **Password**.

4. Click **Save**.

# GEO Fence tab

## Manage GEO Fence

### Enable GEO Fence

#### WebUI Procedure

1. Go to *Security :: GEO Fence*.

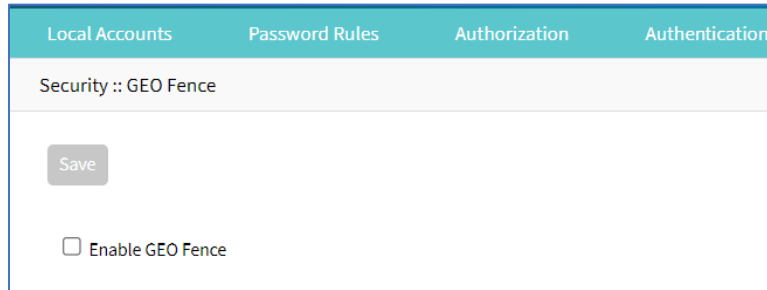

2. Select **Enable GEO Fence** checkbox (displays dialog).

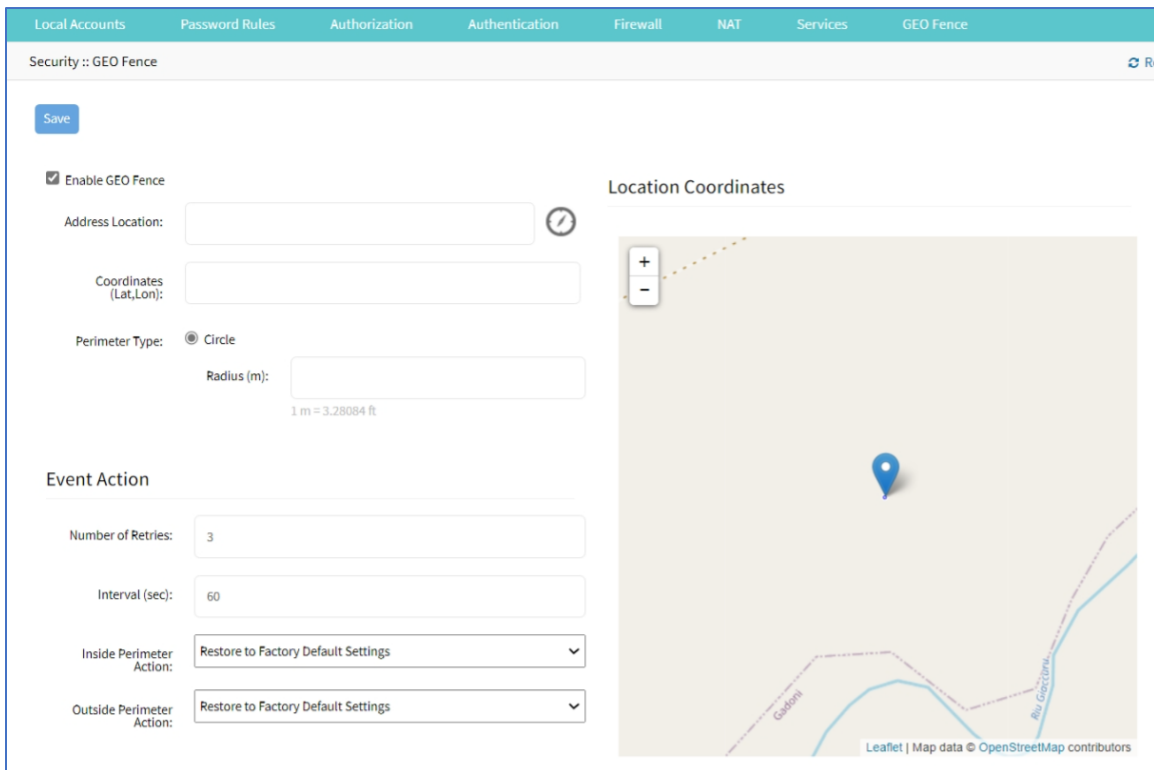

3. Enter **Address Location** (a valid address for the device location).
4. Enter **Coordinates (Lat, Lon)** (if GPS is available, click **Compass** icon  or manually enter GPS coordinates).
5. In Perimeter Type menu:  
Select **Circle** radio button (default).

Enter **Radius (m)**.

6. In *Event Action* menu:

Enter **Number of Retries** (default: 3).

Enter **Interval (sec)** (default: 60).

On **Inside Perimeter Action** drop-down, select one (**template.py**, **template.sh**, **template\_change\_system\_init.sh**, **template\_send\_sms.sh**, **Restore to Factory Default Settings**).

On **Outside Perimeter Action** drop-down, select one.

7. Click **Save**.

## **SED Pre-Boot Authenticator (PBA)**

### **Install or upgrade SED Pre-Boot authenticator**

SED must be disabled before upgrading or installing the SED PBA. If currently enabled, enter the unlock password and disable it.

1. Contact a ZPE representative to get valid copies of these PBA image files:

pba.img

pba.img.sha256

2. Copy the files to /var/sed
3. Restart the system and boot into Rescue Mode.
4. Execute the script:

```
/usr/sbin/sed_install.sh
```

5. When prompted, type:

```
continue.\
```

6. Enter the path to the SED PBA image file.
7. Enter the path to the SED PBA Image hash file.
8. Accept the SED PBA version check.
9. Wait for the installation to complete.
10. Once complete, power cycle the device for changes to take effect.

## RFID Tag tab

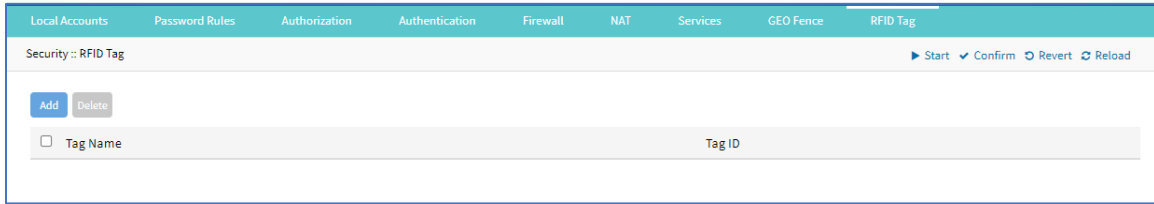

This tab lists authorized RFID Keys. Currently, these keys are linked to the RFID Door Lock. When a RIFD Reader door lock is connected to the Nodegrid device, a card with the correct RFID tag (on this list) must be inserted to unlock the door.

**NOTE:** When the RIFD Reader door lock is connected to the Nodegrid device, it is automatically recognized.

### Manage RFID Tag

#### Add RFID Tag

##### WebUI Procedure

1. Go to *Security :: RFID Tag*.
2. Click **Add** (displays dialog).

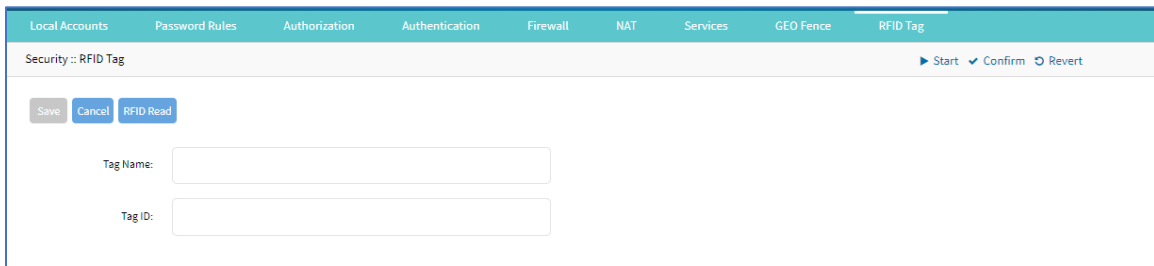

3. Enter **Tag Name**.
4. Enter **Tag ID**.
5. Click **Save**.

#### Read RFID Tag from Card

##### WebUI Procedure

1. Go to *Security :: RFID Tag*.
2. Click **Add** (displays dialog).
3. Click **RIFD Read**.
4. Insert Card into RIFD Reader.
5. The **Tag Name** and **Tag ID** are populated.
6. Click **Save**.

7. Repeat for additional cards.

## Delete RFID Tag

### WebUI Procedure

1. Go to *Security :: RFID Tag*.
2. Select checkbox.
3. Click **Delete**.

# Auditing Section

This tracks events and data logging settings. Events can be distributed with four different methods: Email, File, SNMP Trap, and Syslog. Data logging and events logging can be stored locally, remotely (via NFS) or sent to a syslog server.

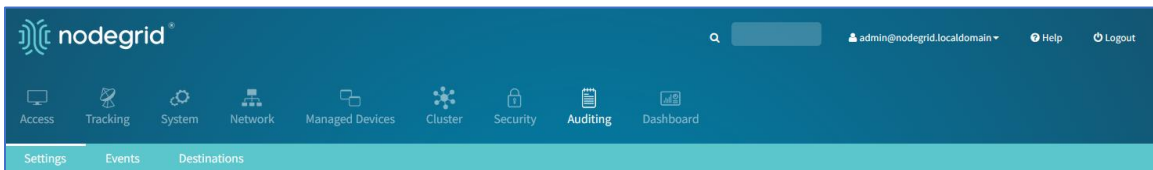

## Settings tab

Log settings are configured here. Data logging captures the data stream on the device, as well as to and from devices.

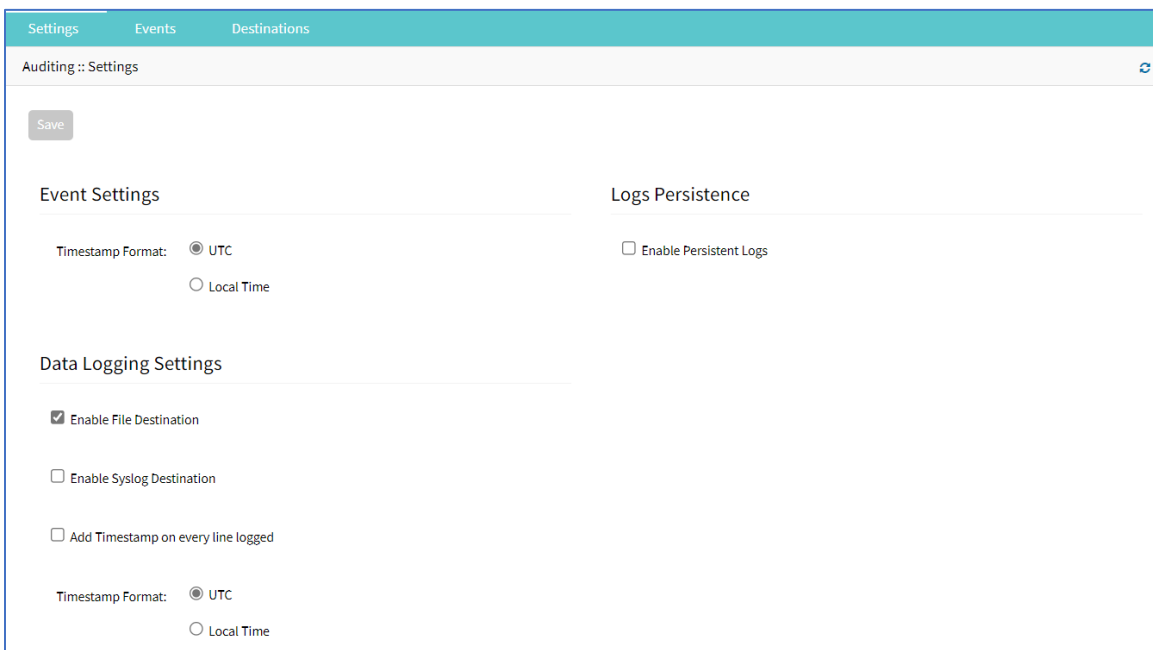

## Data Logging Settings

### Update Logging Settings

#### WebUI Procedure

1. Go to *Auditing :: Settings*.

2. In *Event Setting* menus

In **Timestamp Format**, select one:

**UTC** radio button (default).

**Local Time** radio button.

3. In *Data Logging Settings* menu:

Select **Enable File Destination** checkbox (if enabled, data logs stored at location defined in *Auditing :: Destination* - default: enabled).

Select **Enable Syslog Destination** checkbox (if enabled, data logs stored at location defined in *Auditing :: Destination* - default: disabled).

Select **Add Timestamp on every line logged** checkbox.

In **Timestamp Format**, select one:

**UTC** radio button (default).

**Local Time** radio button.

4. In *Logs Persistence* menu:

Select **Enable Persistent Logs** checkbox (expands dialog)

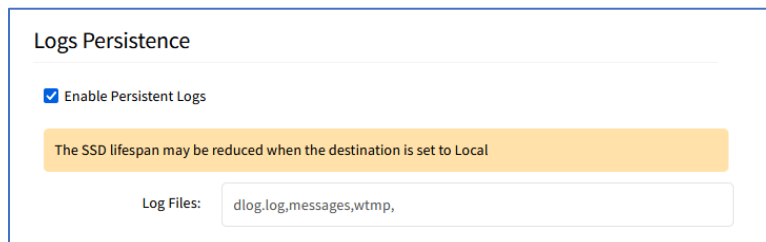

Accept **Log Files** (default values: dlog.log,messages,wtmp,), or edit, as needed.

5. Click **Save**.

## Events tab

Events are automatically logged based on event and device settings. By default, all events are stored to the local file system. This behavior is adjusted under *Auditing :: Events*. The administrator can configure to which destination events and which event categories are logged.

There are four event categories:

- Systems Events

- AAA Events
- Device Events
- Logging Events

### Event List sub-tab

This is a list of events. The table lists all current event types: 100 – 527 (list can be variable).

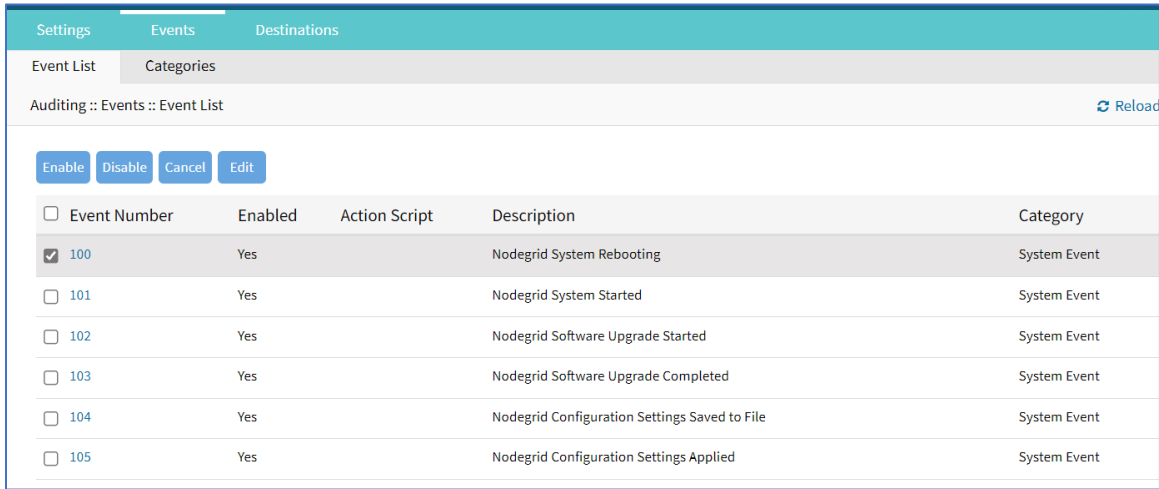

Event Number	Enabled	Action Script	Description	Category
<input checked="" type="checkbox"/> 100	Yes		Nodegrid System Rebooting	System Event
<input type="checkbox"/> 101	Yes		Nodegrid System Started	System Event
<input type="checkbox"/> 102	Yes		Nodegrid Software Upgrade Started	System Event
<input type="checkbox"/> 103	Yes		Nodegrid Software Upgrade Completed	System Event
<input type="checkbox"/> 104	Yes		Nodegrid Configuration Settings Saved to File	System Event
<input type="checkbox"/> 105	Yes		Nodegrid Configuration Settings Applied	System Event

### Enable/Disable Event

#### WebUI Procedure

1. Go to *Auditing :: Events :: Event List*.
2. Locate and select checkbox(es).
3. Click **Enable** (enables reporting of that event type).

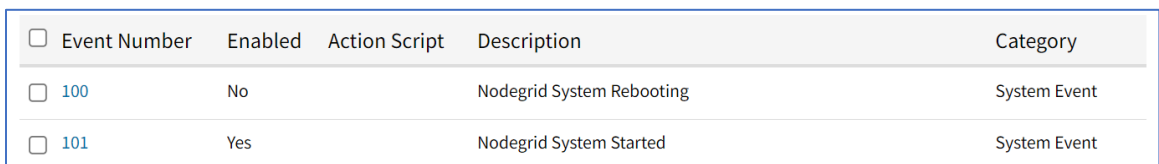

Event Number	Enabled	Action Script	Description	Category
<input type="checkbox"/> 100	No		Nodegrid System Rebooting	System Event
<input type="checkbox"/> 101	Yes		Nodegrid System Started	System Event

4. Click **Disable** (disables reporting of that event type).



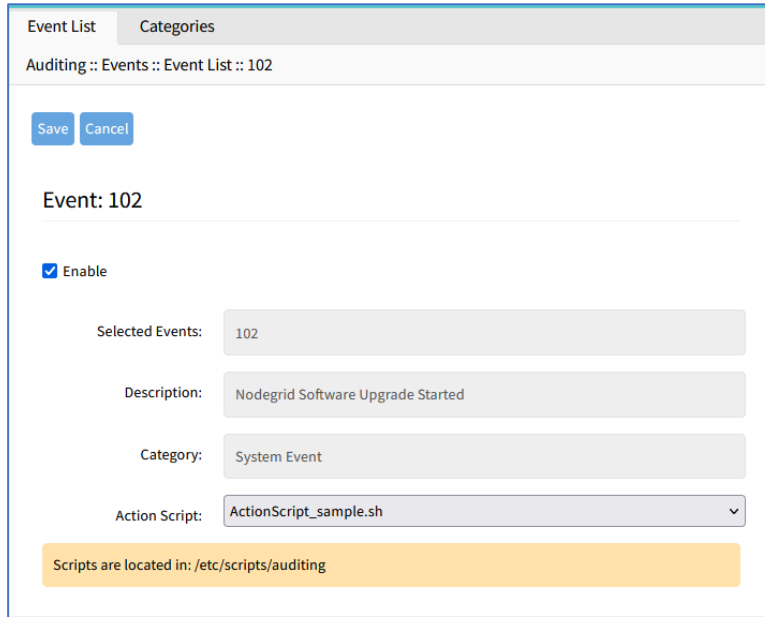

Edit Event

**WebUI Procedure**

1. Go to *Auditing :: Events :: Event List*.
2. Locate and select checkbox.
3. Click **Edit** (displays dialog).

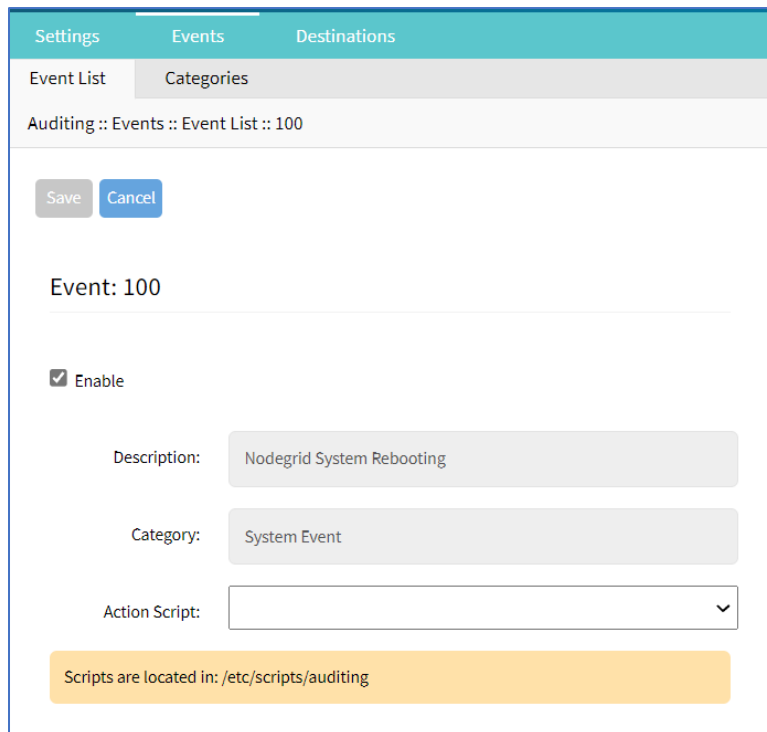

4. Select/unselect **Enable** checkbox (must be enabled to report occurrence).
5. On **Action Script** drop-down, select one (list is based on existing scripts).

**NOTE:** If event is enabled, and an action script assigned, the script runs when the event occurs.

6. Click **Save**.

## Categories sub-tab

Category reporting is defined here. Table indicates current settings for reporting.

Settings	Events	Destinations			
Event List	Categories				
Auditing :: Events :: Categories <span style="float: right;">Rel</span>					
Events	System Events	AAA Events	Device Events	Logging Events	ZPE Cloud Events
ZPE Cloud	-	-	-	-	Yes
Email	-	-	-	-	-
File	Yes	Yes	Yes	Yes	Yes
SNMP Trap	-	-	-	-	-
Syslog	Yes	Yes	Yes	Yes	Yes

## Set Categories

This procedure uses ZPE Cloud as an example.

### WebUI Procedure

1. Go to *Auditing :: Events :: Categories*.
2. In *Events* column, click **ZPE Cloud** (displays dialog).

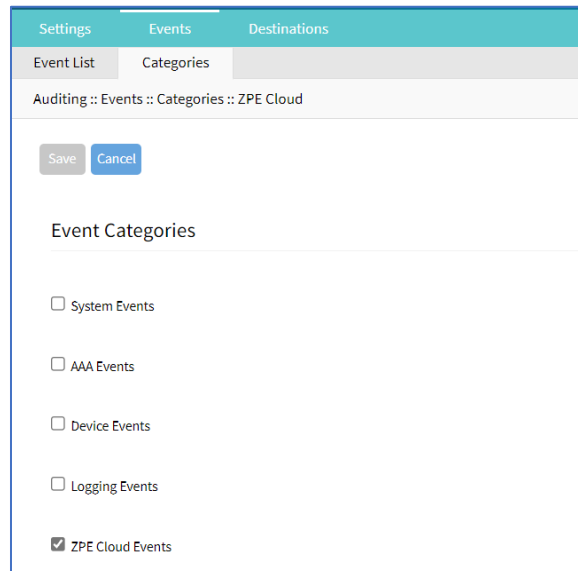

3. Select other checkboxes, as needed.
4. Select **ZPE Cloud Events** checkbox (to report events that occur in ZPE Cloud).
5. Click **Save**.

## Set Categories for Email

### WebUI Procedure

1. Go to *Auditing :: Events :: Categories*.
2. In *Events* column, click **Email** (displays dialog).

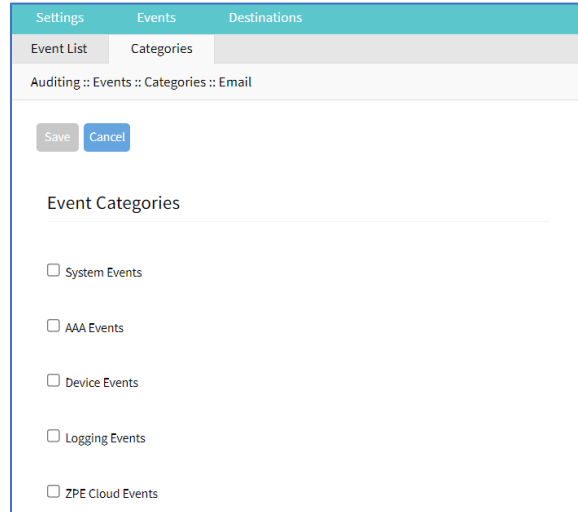

3. Select checkbox(es) that, when event occurs, email is sent (configured in *Auditing :: Destinations :: Email*).
4. Click **Save**.

## Set Categories for File

### WebUI Procedure

1. Go to *Auditing :: Events :: Categories*.
2. In *Events* column, click **File** (displays dialog).

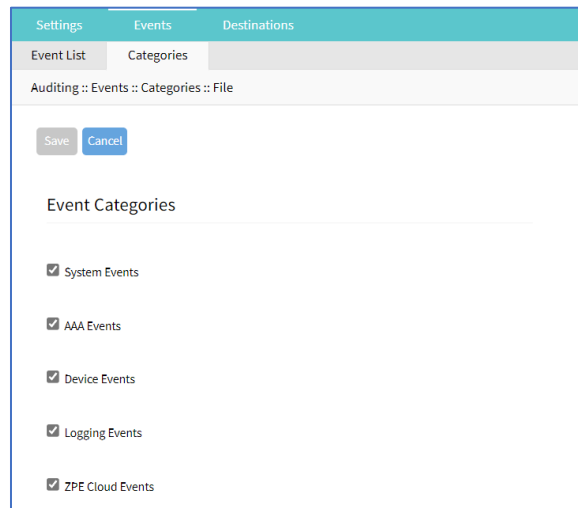

3. Select/unselect checkboxes, as needed.

4. Click **Save**.

## Set Categories for SNMP Trap

### WebUI Procedure

1. Go to *Auditing :: Events :: Categories*.
2. In *Events* column, click **SNMP Trap** (displays dialog).

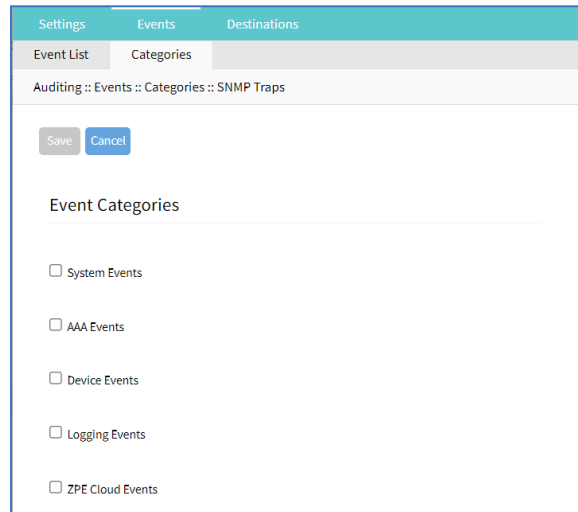

The screenshot shows a web interface with three tabs: 'Settings', 'Events', and 'Destinations'. The 'Events' tab is active, and within it, the 'Categories' sub-tab is selected. The breadcrumb path is 'Auditing :: Events :: Categories :: SNMP Traps'. At the top left of the dialog are 'Save' and 'Cancel' buttons. Below is the 'Event Categories' section with a list of categories and their checkboxes:

- System Events
- AAA Events
- Device Events
- Logging Events
- ZPE Cloud Events

3. Select/unselect checkboxes, as needed.
4. Click **Save**.

## Set Categories for Syslog

### WebUI Procedure

1. Go to *Auditing :: Events :: Categories*.
2. In *Events* column, click **Syslog** (displays dialog).

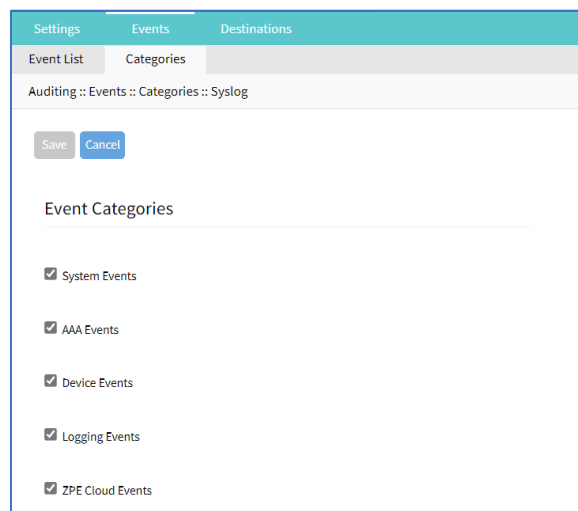

The screenshot shows a web interface with three tabs: 'Settings', 'Events', and 'Destinations'. The 'Events' tab is active, and within it, the 'Categories' sub-tab is selected. The breadcrumb path is 'Auditing :: Events :: Categories :: Syslog'. At the top left of the dialog are 'Save' and 'Cancel' buttons. Below is the 'Event Categories' section with a list of categories and their checkboxes:

- System Events
- AAA Events
- Device Events
- Logging Events
- ZPE Cloud Events

3. Select/unselect checkboxes, as needed.
4. Click **Save**.

## Destinations tab

Event Destinations are defined here.

### File sub-tab

File destination and archive settings are configured here. By default, data logs are written to local files.

**NOTE:** NFS requires RPC service to be enabled (*Security :: Services*).

### Configure File Settings

#### WebUI Procedure – Local Destination

1. Go to *Auditing :: Destinations :: File*.

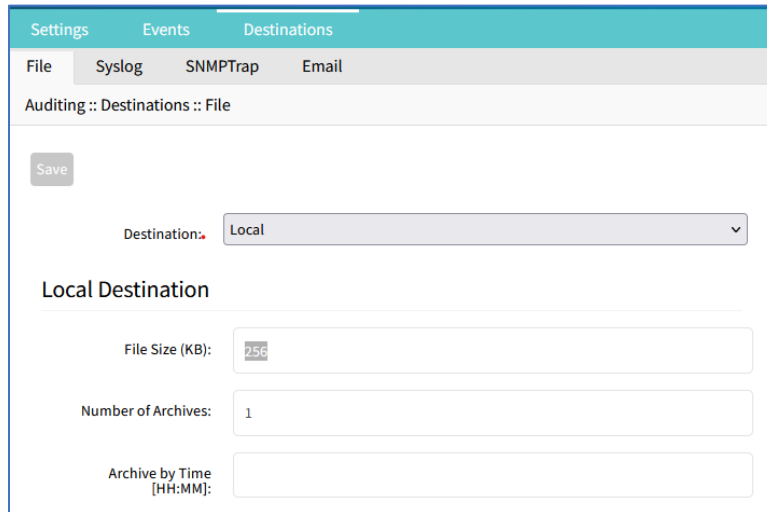

2. On **Destination** drop-down, select **Local** (expands dialog):

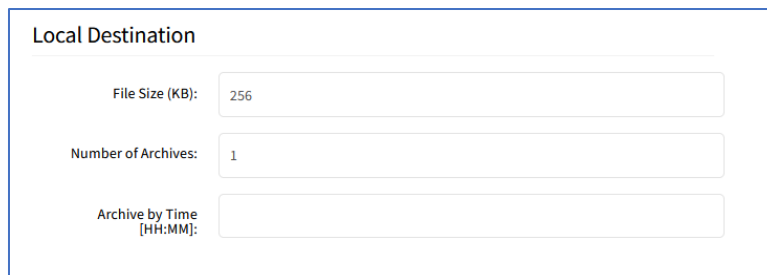

Enter **File Size [Kbytes]** (0=disabled, up to 2048 KB - default: 1024).

Enter **Number of Archives** (number of archive files before discard - default: 0, max: 99).

Enter **Archive by Time [HH:MM]** (when file archive is rotated - default: blank).

3. On **Destination** drop-down, select **NFS** (expands dialog):

**NFS Destination**

NFS Server:

NFS Path:

File Size (KB):

Number of Archives:

NFS Archive by Time [HH:MM]:

NFS requires RPC service to be enabled in Security :: Services.

Enter **NFS Server** (IP address of NFS server).

Enter **NFS Path** (path to NFS root directory).

Enter **File Size [Kbytes]** (0=disabled, up to 2048 KB - default: 1024).

Enter **Number of Archives** (number of archive files before discard - default: 0, max: 99).

Enter **NFS Archive by Time [HH:MM]** (when file archive is rotated - default: blank).

4. Click **Save**.

## Syslog sub-tab

Support destinations are: local Syslog destination or remote IPv4 and IPv6 destination.

Settings   Events   Destinations

File   Syslog   SNMPTrap   Email

Auditing :: Destinations :: Syslog

Save

System Console

Admin Session

IPv4 Remote Server

IPv6 Remote Server

Event Facility:

Data Logging Facility:

## Configure Syslog Settings

### WebUI Procedure

1. Go to *Auditing :: Destinations :: Syslog*.
2. Select **System Console** checkbox.
3. Select **Admin Session** checkbox.
4. Select **IPv4 Remote Server** checkbox.

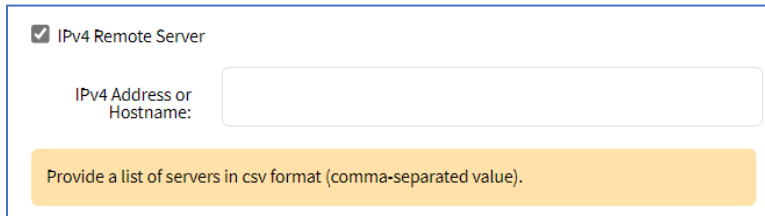

Enter **IPv4 Address or Hostname**.

5. Select **IPv6 Remote Server** checkbox.

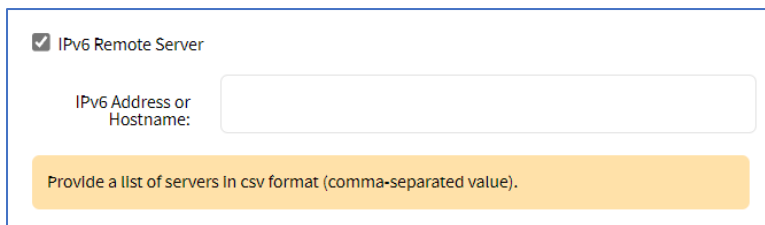

Enter **IPv6 Address or Hostname**.

6. On **Event Facility** drop-down, select one (**Log Local 0, Log Local 1, Log Local 2, Log Local 3, Log Local 4, Log Local 5**).
7. On **Data Logging Facility** drop-down, select one (**Log Local 0, Log Local 1, Log Local 2, Log Local 3, Log Local 4, Log Local 5**).
8. Click **Save**.

### ***SNMP Trap sub-tab***

Any triggered event can be sent as an SNMP trap to an existing NMS system. SNMP v2 and 3 for traps is supported. The MIB files for the device are available together with the firmware files.

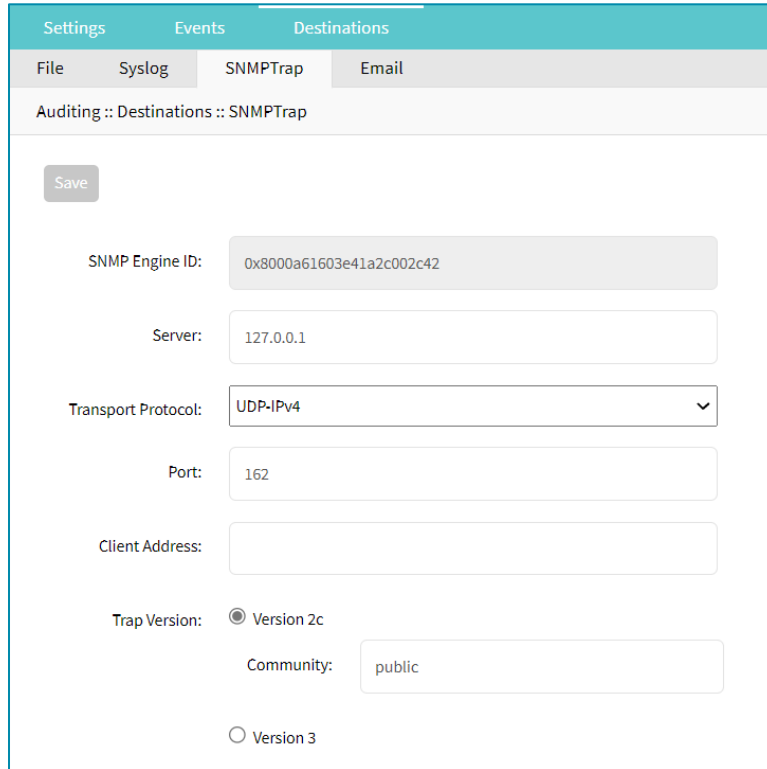

## Configure SNMP Trap Settings

### WebUI Procedure

1. Go to *Auditing :: Destinations :: SNMP Trap*.
2. Enter **Server**.
3. On **Transport Protocol** drop-down, select one (**UDP-IPv4, TCP-IPv4, UDP-IPv6, TCP-IPv6**) (protocol to send traps - default: UDP-IPv4).
4. Enter **Port** (default: 161).
5. Enter **Client Address**.
6. In *Trap Version* menu, select one:

**NOTE:** SNMP3 INFORM messages are currently not supported.

**Version 2c** radio button.

Enter **Community**.

**Version 3** radio button.

Enter **User Name**.

On **Security Level** drop-down, select one (**noAuthNoPriv, authNoPriv, authPriv**).

On **Authentication Algorithm** drop-down, select one (**MD5, SHA**).

Enter **Authentication Password**.



On **Privacy Algorithm** drop-down, select one (**DES, AES**).

Enter **Privacy Passphrase**.

7. Click **Save**.

## Access MIB files

### CLI Procedure

The MIB files are located as follows:

```
root@nodegrid:~# ls -l /usr/local/mibs/
total 104
-rw-r--r-- 1 root root 36940 Nov 20 2017 NodeGrid-MIB.asn
-rw-r--r-- 1 root root 61403 Nov 20 2017 NodeGrid-TRAP-MIB.asn
-rw-r--r-- 1 root root 2732 Nov 20 2017 ZPESystems.smi
```

## Email sub-tab

Events can be sent to an email address.

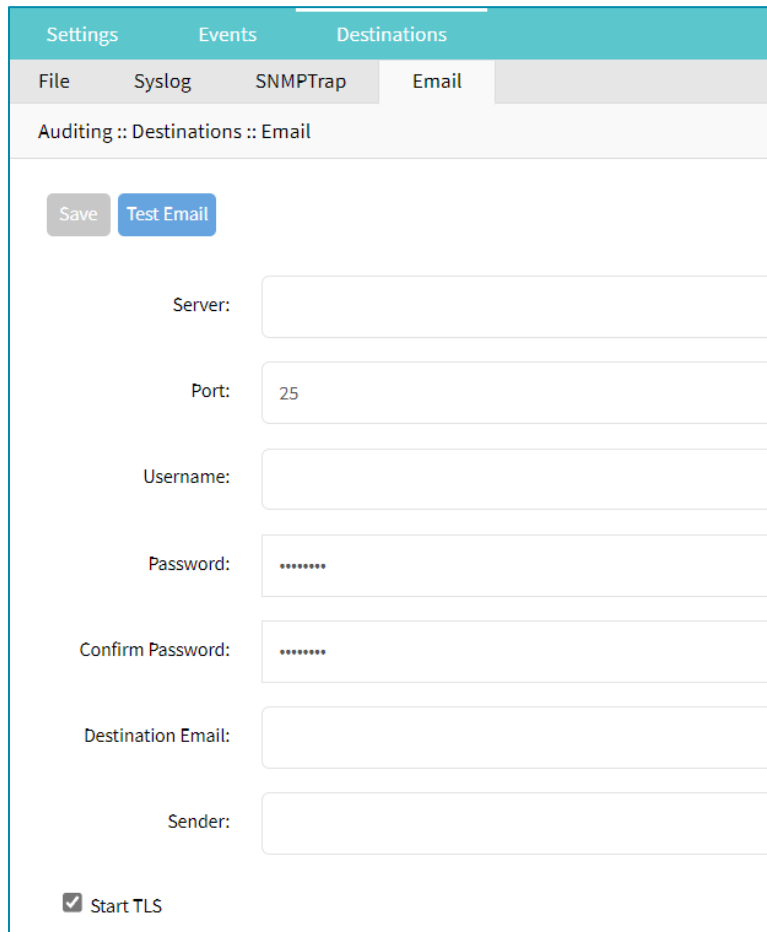

The screenshot shows the 'Email' sub-tab under 'Destinations' in the configuration interface. The breadcrumb path is 'Auditing :: Destinations :: Email'. There are two buttons: 'Save' and 'Test Email'. The form contains the following fields:

- Server: [Empty text input]
- Port: 25
- Username: [Empty text input]
- Password: [Password input with masked characters]
- Confirm Password: [Password input with masked characters]
- Destination Email: [Empty text input]
- Sender: [Empty text input]

At the bottom left, there is a checked checkbox labeled 'Start TLS'.

## Configure Email Settings

### WebUI Procedure

1. Go to *Auditing :: Destinations :: Email*.
2. Enter **Server**.
3. Enter **Port** (default: 25).
4. Enter **Username**.
5. Enter **Password** and **Confirm Password**.
6. Enter **Destination Email**.
7. Enter **Sender**.
8. Select **Start TLS** checkbox (if TLS is used for communication).
9. Click **Save**.

## Dashboard Section

The Dashboard (WebUI only) allows visual presentations of Event activities, Managed Device details, and data monitoring. Multiple dashboards can be created for different purposes. For example, one to monitor managed device data points (i.e., Power Consumption, Voltage, Current, Temperature, Fan speed, etc.) Another dashboard can monitor Nodegrid events such as authentication failures, login, and logout

## Description

### Navigation Tabs

Navigation tabs are located on the left panel.

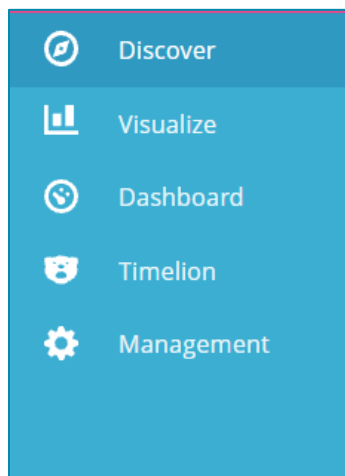

## Toolbar Description

The Toolbar is show across top of the panel.

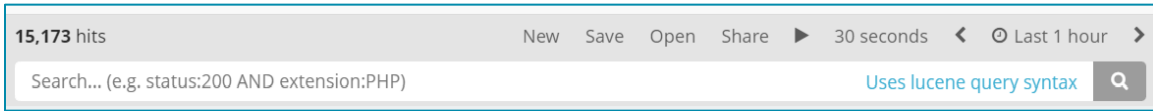

### New

Initiates an option to create a new option – visualization, panel, etc.

### Save

Saves the settings of the current configuration with any modifications.

### Open

Displays Open Search dialog.

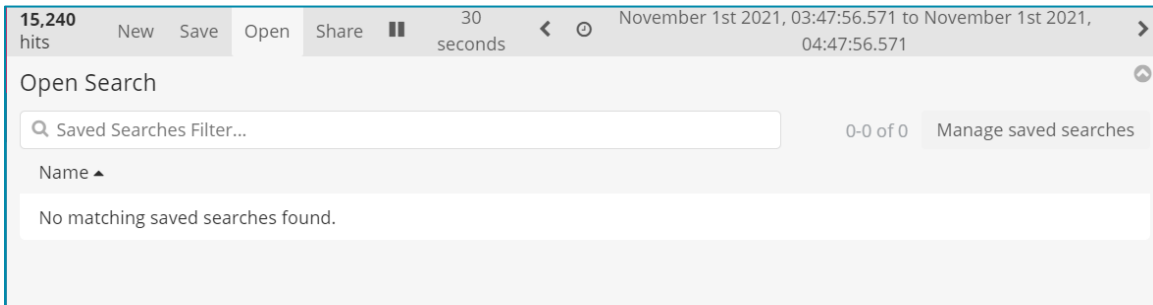

### Share

Opens *Share* dialog options of the current saved search.

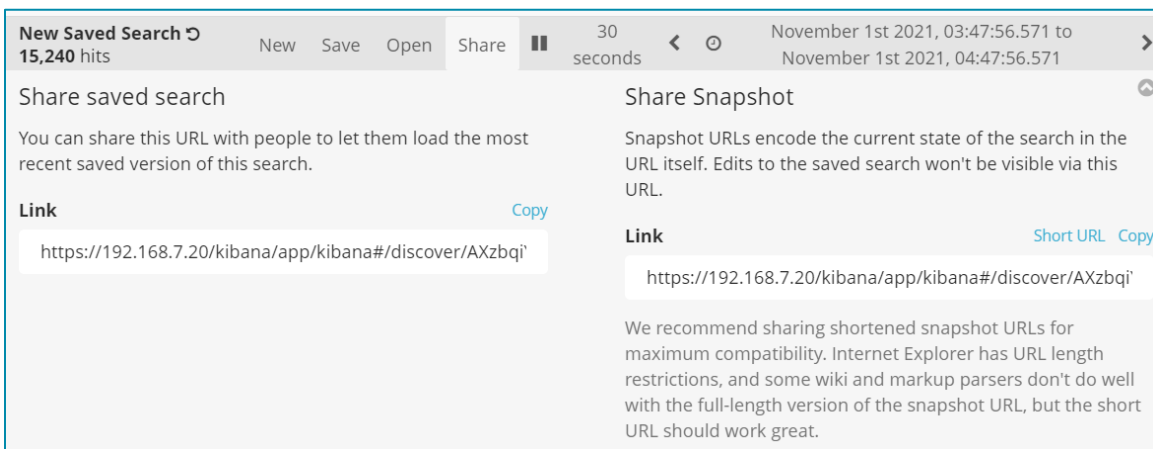

Click to play discovery to include modifications. Useful for testing parameter changes before saving.

## < (back)

Click to move the display back in time.

## Refresh interval

How often the results are checked and shown in the display.

15,240 hits    New   Save   Open   Share   ||   30 seconds   <   November 1st 2021, 03:47:56.571 to November 1st 2021, 04:47:56.571   >

Refresh Interval

Off	5 seconds	1 minute	1 hour
	10 seconds	5 minutes	2 hour
	<b>30 seconds</b>	15 minutes	12 hour
	45 seconds	30 minutes	1 day

## Quick sub-tab

Quick options to select a relative time frame to current time.

15,240 hits    New   Save   Open   Share   ||   30 seconds   <   November 1st 2021, 03:47:56.571 to November 1st 2021, 04:47:56.571   >

Time Range

<b>Quick</b>	Today	Yesterday	Last 15 minutes	Last 30 days
Relative	This week	Day before yesterday	Last 30 minutes	Last 60 days
Absolute	This month	This day last week	Last 1 hour	Last 90 days
	This year	Previous week	Last 4 hours	Last 6 months
	The day so far	Previous month	Last 12 hours	Last 1 year
	Week to date	Previous year	Last 24 hours	Last 2 years
	Month to date		Last 7 days	Last 5 years
	Year to date			

## Relative sub-tab

Select custom time frames in relation to current time.

15,240 hits    New   Save   Open   Share   ||   30 seconds   <   November 1st 2021, 03:47:56.571 to November 1st 2021, 04:47:56.571   >

Time Range

Quick

**Relative**

Absolute

From: November 1st 2021, 04:11:02.875   Set To Now

To: November 1st 2021, 05:11:02.875   Set To Now

2   Hours ago

1   Hours ago

round to the hour    round to the hour

Go

## Absolute sub-tab

Select fixed dates/times.

15,240 hits    New   Save   Open   Share   ▶   30 seconds   <   November 1st 2021, 03:47:56.571 to November 1st 2021, 04:47:56.571   >

Time Range

Quick

Relative

**Absolute**

From:    Set To Now

To:    Set To Now

Go

YYYY-MM-DD HH:mm:ss.SSS   YYYY-MM-DD HH:mm:ss.SSS

<   November 2021   >

Sun	Mon	Tue	Wed	Thu	Fri	Sat	Sun	Mon	Tue	Wed	Thu	Fri	Sat		
		01	02	03	04	05	06			01	02	03	04	05	06
07	08	09	10	11	12	13	07	08	09	10	11	12	13		
14	15	16	17	18	19	20	14	15	16	17	18	19	20		
21	22	23	24	25	26	27	21	22	23	24	25	26	27		
28	29	30					28	29	30						

## > (forward)

Click to moves the display forward in time.

### Search bar

Enter search criteria to locate details. Search expressions are used to select/limit data points on the visualization. They can be used as a filter for the whole visualization, or as a filter for the whole dashboard.

Search expressions are not restricted to data point fields. An expression can also refer to fields associated with the device (type, IP address, groups, custom fields, and more). For example, to collect current from each outlet in a selection of Rack PDUs, use one custom field “rack:abc” with another custom field “rack:xyz”. Here are some search examples:

- host:"ServertechPDU"
- collectd\_type:"power"
- type\_instance:"AA1"
- collectd\_type:"power" AND type\_instance:"AA1"

### Configuration Expressions of Data Points

#### Data Point fields (logstash-\* Index )

Field	Value	Description
host	Device Name	Name of the device being monitored.
plugin	snmp, ipmi, nominal, aggregation	Name of the collection plugin.
plugin_instance	sum, average	Instance of the plugin collecting the data, if the plugin requires it. Present in the aggregation plugin.
collectd_type	temperature, fan speed, humidity, counter, percent time left, voltage, current power, apparent_power, power_factor, frequency	Type of measurement.
type_instance	Data Point Name	Name of the element associated with measurement.

#### Device fields (logstash-\* Index )

Field	Values	Description
name	Device Name	Name of the device being monitored.
mode	enabled, on demand, disabled	Device operational mode.
type	device type	Device type (assigned under Managed Devices).

Field	Values	Description
family	ilo, drac, ipmi_1.5, ilmi_2.0, cimc_ucs, device_console, pdu	Device family.
addr_location	Address	Address (street, city, country).
coordinates	Coordinates	Latitude, longitude.
ip	IP address	Device IP address.
mac	MAC address	Device MAC address (if known).
alias	IP address alias	Alias of the IP address.
groups	list of groups	Groups authorized to access the device.
licensed	yes, no	Device license state.
status	connected, disconnected, in-use, unknown	Current device status.
nodegrid	Nodegrid hostname	Device hostname that controls the device.
custom fields		Any configured custom field for the device.

### Event fields (\*\_date\_\* Index )

Field	Value	Description
event_id	Number	Event ID number.
event_msg	Text	Event message.
host	Nodegrid hostname	Device hostname on which the event occurred.
message	Text	Full message text.

## Discover tab

### Data Point Exploration

This allows an inspection of the entire json document that was indexed

### Collect Raw Data Points

1. Go to *Dashboard :: Discover*.

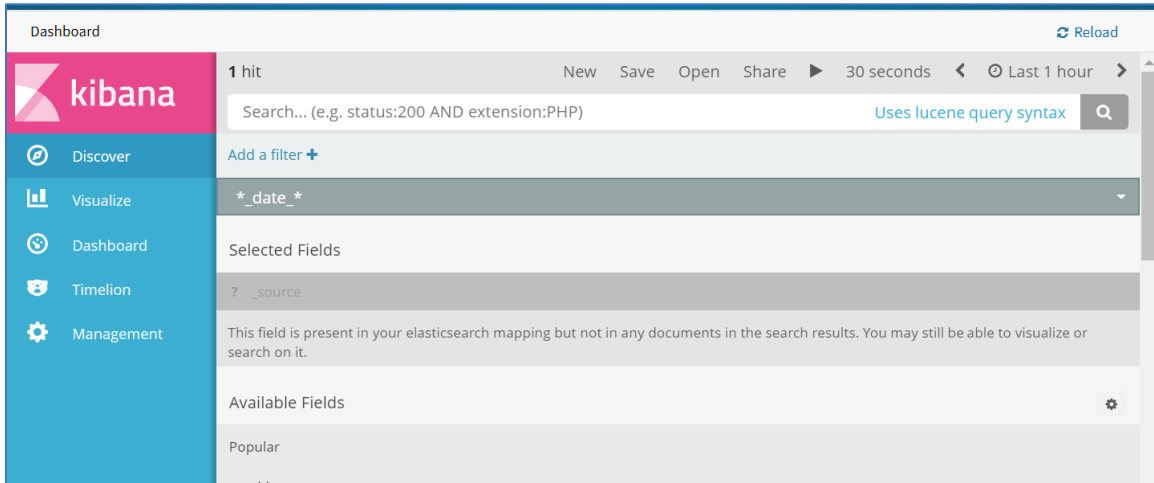

2. Click in the dark bar. On the drop-down, select the *Index Pattern*:

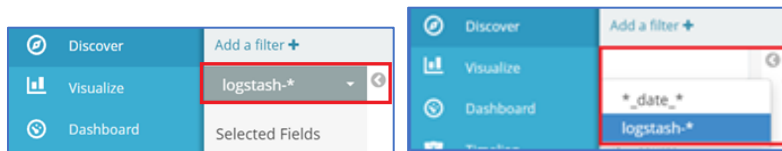

**logstash-\*** (contains monitored data)

**\*\_date\_\*** (contains event notifications)

3. Adjust the time frame as needed

By default, all displayed data is collected within the defined time frame.

4. Use **Search** to find a specific device or data point.

5. Verify that data points were collected.

6. Inspect the available fields.

**NOTE:** Collected data is buffered before stored. it may take up to a few minutes for data to display. If the data source produces a lot of content, buffers quickly fill up.

## Visualize tab

Visualizations display aggregate data in a variety of options. Following are descriptions of data presentation.

### Line Charts

Line Charts allow the visualization of data points along the line graph.

### Create a Single or Multi-Line Chart (Configuration Example)

#### WebUI Procedure

1. Go to *Dashboard :: Visualize*.
2. Click the + icon.



3. This displays the *Select visualization type* dialog.

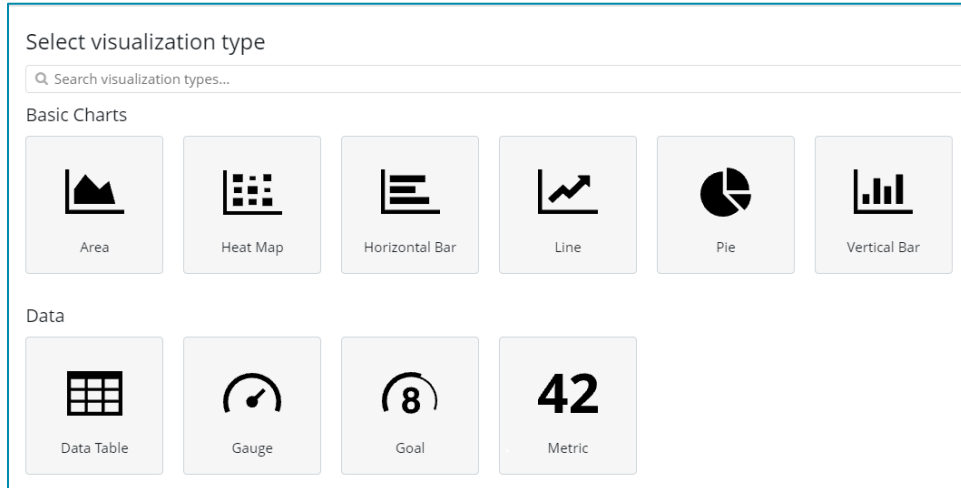

4. Click the **Line** icon. On the dialog, click **logstash-\***.

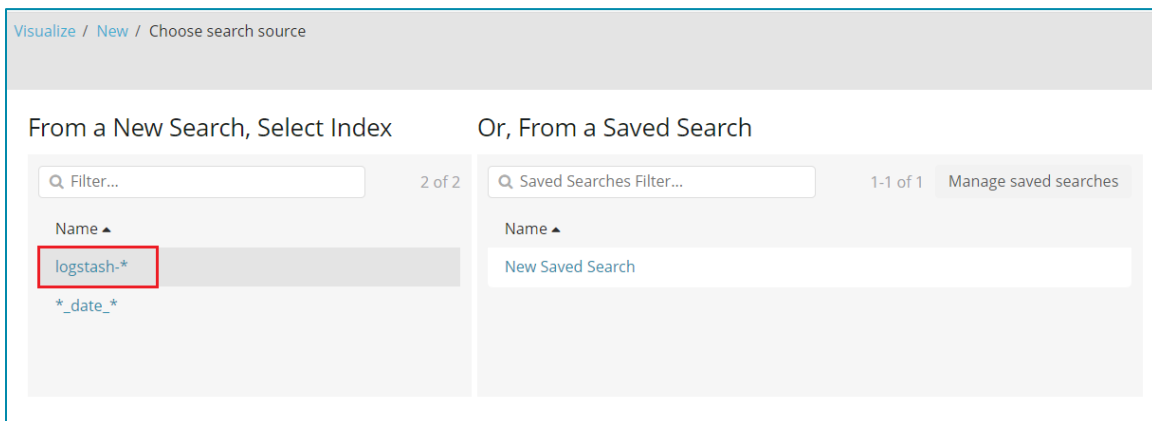

5. In the *From a New Search, Select Index* menu, click **logstash-\*** (displays editor dialog).



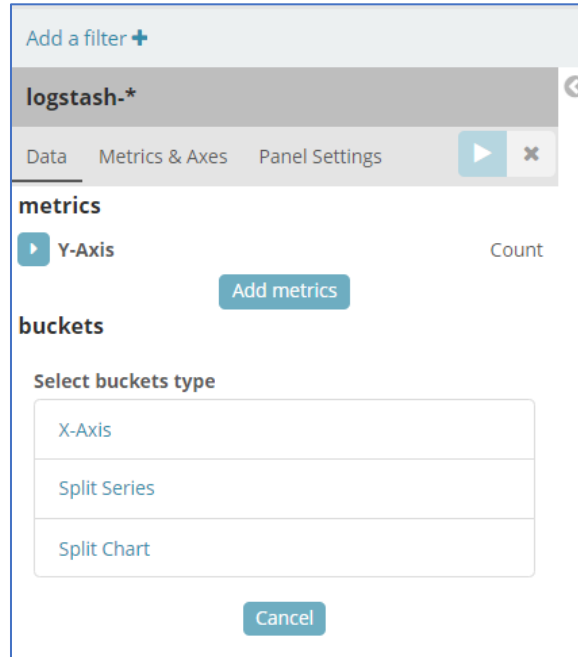

- To select the data points to visualize, enter a search expression.

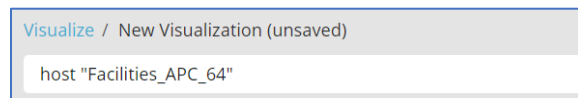

The search expression can be extended.

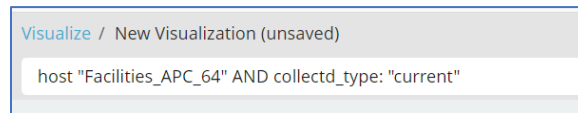

- In the *Metrics* section, click **Y-Axis** arrow.

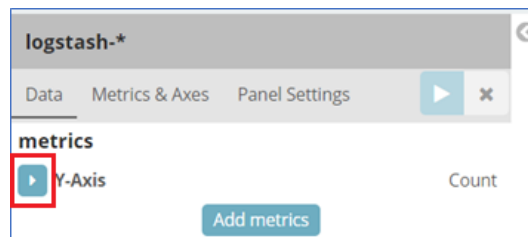

- On the **Aggregation** drop-down, under *Metric Aggregations* section, select **Average** . In **Field** drop-down, select **value**.

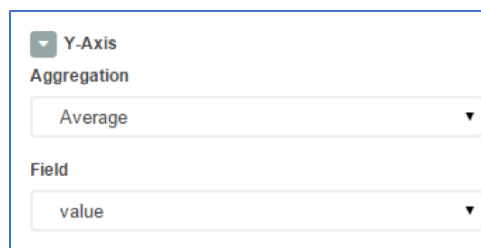

9. In *buckets* section, in *Select buckets type* menu, click **X-Axis**.

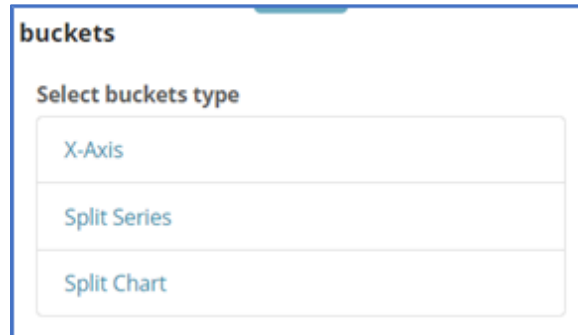

10. On **Aggregation** drop-down, select **Date Histogram**. Accept **Field** and **Interval** defaults.

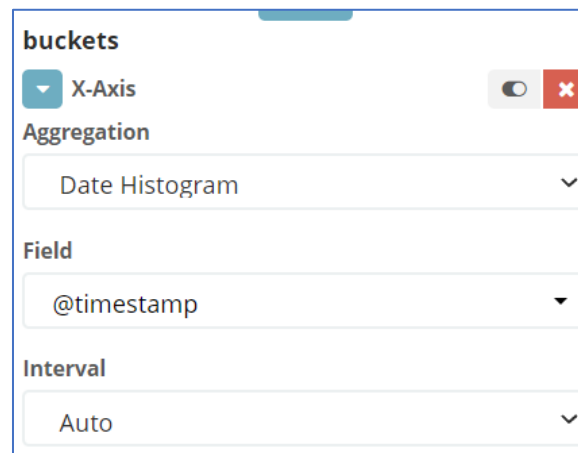

11. On the Toolbar, click **Save** (displays dialog).

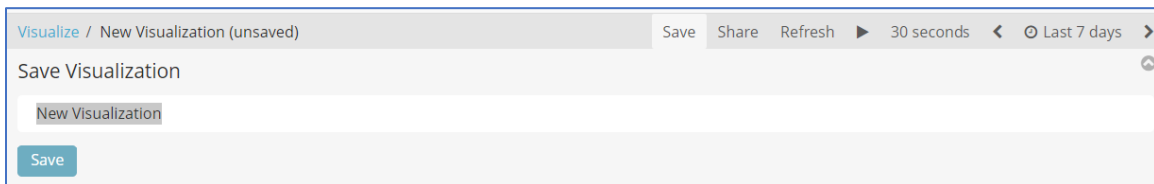

12. Enter a name for the visualization and click **Save**.

## Create a Multi-Line Chart (Configuration Example)

Follow the Single-Line Chart example and continue these steps.

### WebUI Procedure

1. Below **Custom Label** field, click **Add sub-buckets**.

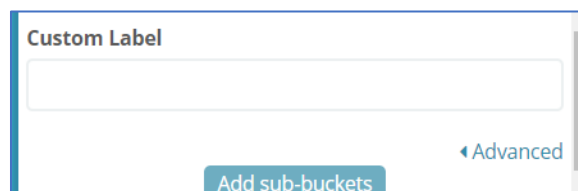

- On the *Select buckets type* menu, click **Split Series**.

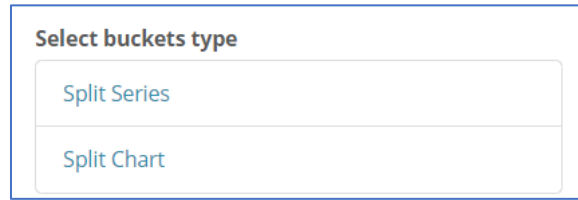

The screenshot shows a menu titled "Select buckets type" with two options: "Split Series" and "Split Chart".

- On **Sub Aggregation** drop-down, select **Filters**.

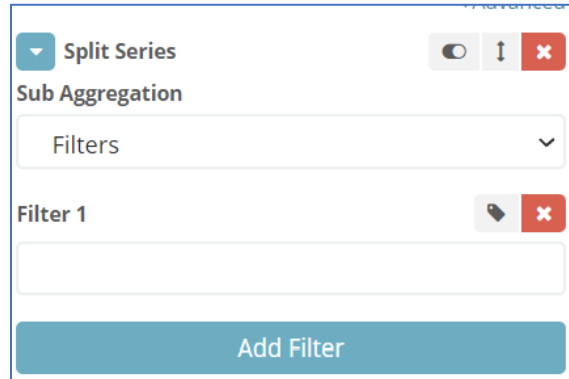

The screenshot shows the "Sub Aggregation" dropdown menu with "Filters" selected. Below it, there is a "Filter 1" section with an empty input field and an "Add Filter" button.

- In **Filter 1**, enter a search expression for the elements to visualize.

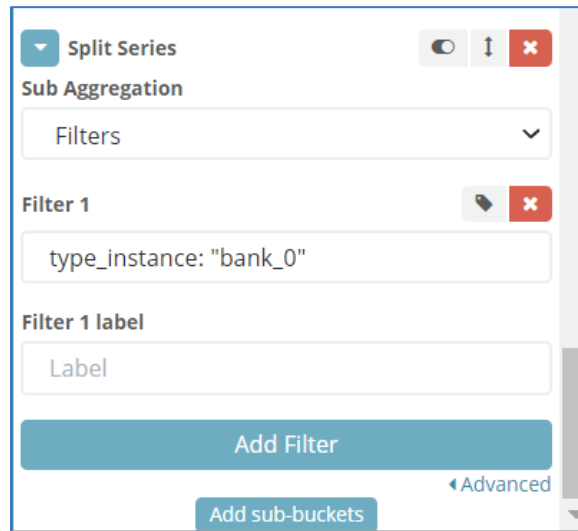

The screenshot shows the "Filter 1" input field containing the search expression "type\_instance: \"bank\_0\"". Below it, there is a "Filter 1 label" field with the text "Label". There is also an "Add Filter" button and an "Add sub-buckets" button at the bottom.

- (optional) To associate a label, click the **Settings** icon and enter **Filter 1 label**.

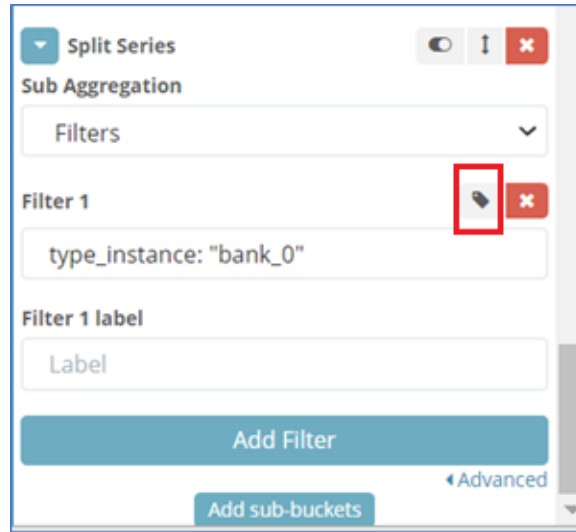

6. (as needed) Click **Add Filter** and repeat.
7. (as needed) Click **Add sub-buckets** and repeat.
8. To refresh the graph based on the configuration, click on the Play icon.

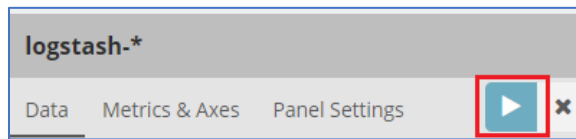

The graph example includes several sub-buckets.



9. On the Toolbar, click **Save** (displays dialog).

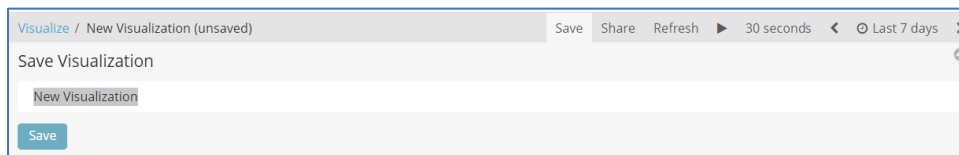

10. Enter a name for the visualization and click **Save**.

## Area Charts

### Create an Area Chart (Configuration Example)

The area chart is useful for stacking measurements for different but related entities.

**NOTE:** Become familiar with the Line Chart procedure before creating an Area Chart,

#### WebUI Procedure

1. Go to *Dashboard :: Visualize*.
2. Click the + icon.

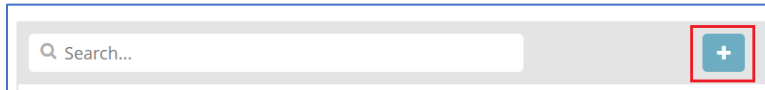

3. This displays the *Select visualization type* dialog.

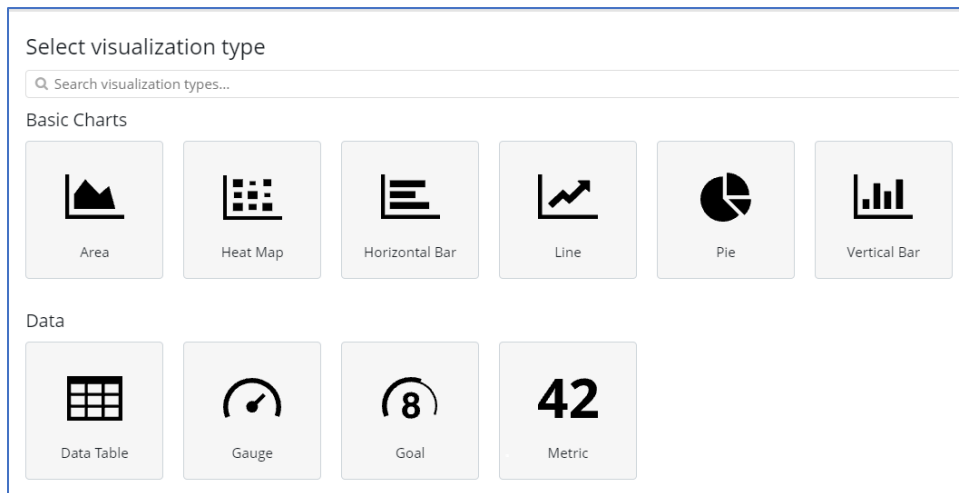

4. Click the **Area** icon. On the dialog, click **logstash-\***.
5. In *metrics* section, click on **Y-Axis** icon. In **Aggregation** drop-down, select **Sum**.

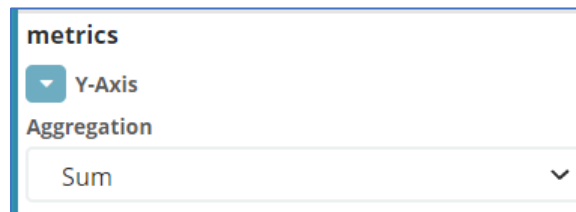

6. On *Buckets* menu, X-Axis, on **Aggregation** drop-down, select **Data Histogram**. In **Interval** drop-down, select **Custom** then enter value (i.e., 30s).

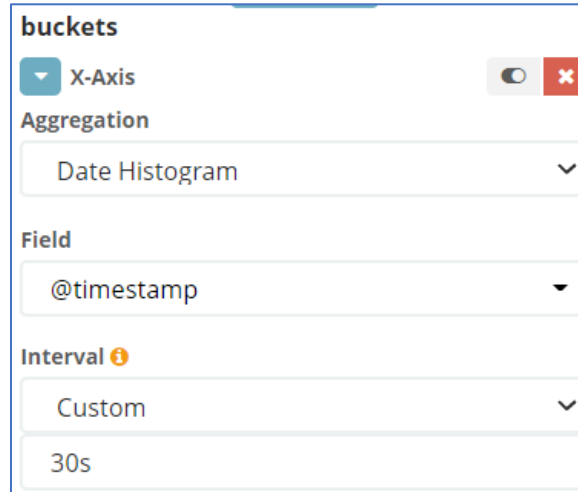

7. Below **Custom Label** field, click **Add sub-buckets**.

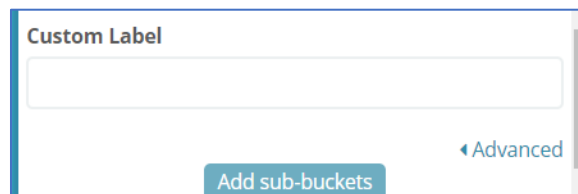

8. On the *Select buckets type* menu, click **Split Series**.

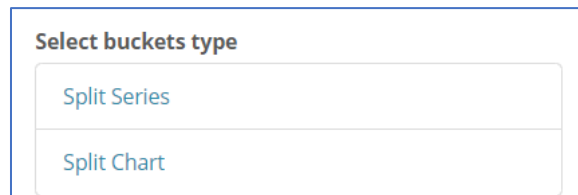

9. On **Sub Aggregation** drop-down, select **Filters**. In **Filter 1**, enter value. Click **Add Filter**.

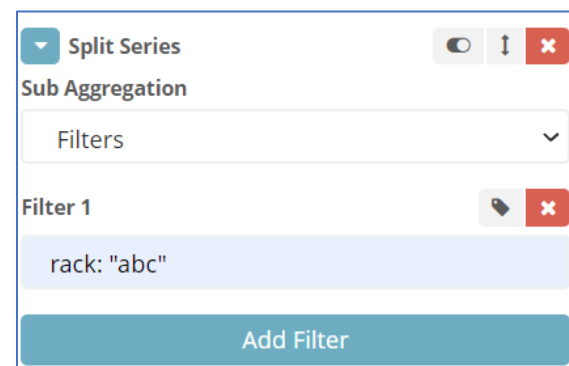

10. In **Filter 2**, enter a search expression for the elements to visualize.

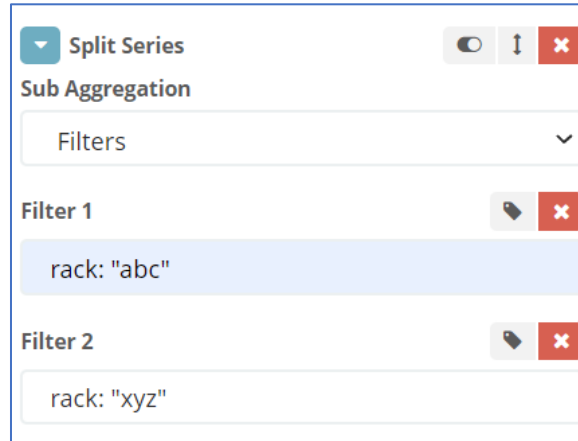

11. (as needed) Click **Add Filter** and repeat.
12. To refresh the graph based on the configuration, click on the Play icon.

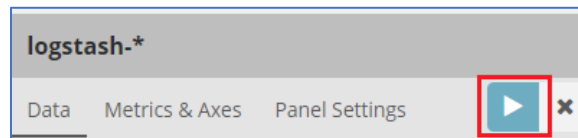

The resulting visualization would look like this:

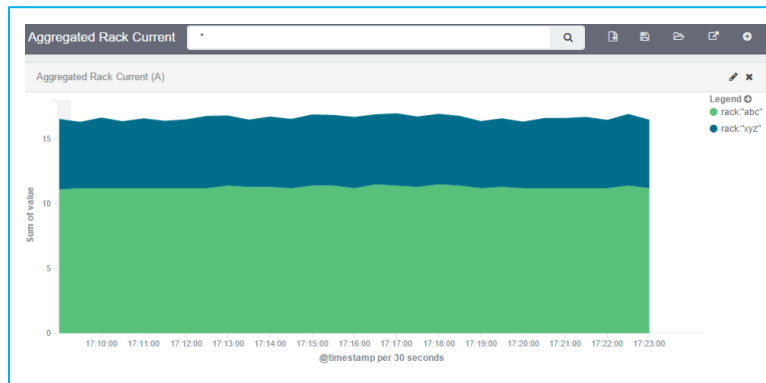

13. On the Toolbar, click **Save** (displays dialog).

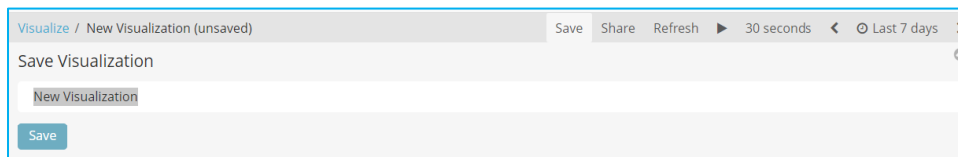

14. Enter a name for the visualization and click **Save**.

**NOTE:** When using area charts, be careful to not use the same measurement twice,

## Dashboard tab

Dashboards are a collection of one or more visualizations. These objects can be created, modified, and deleted.

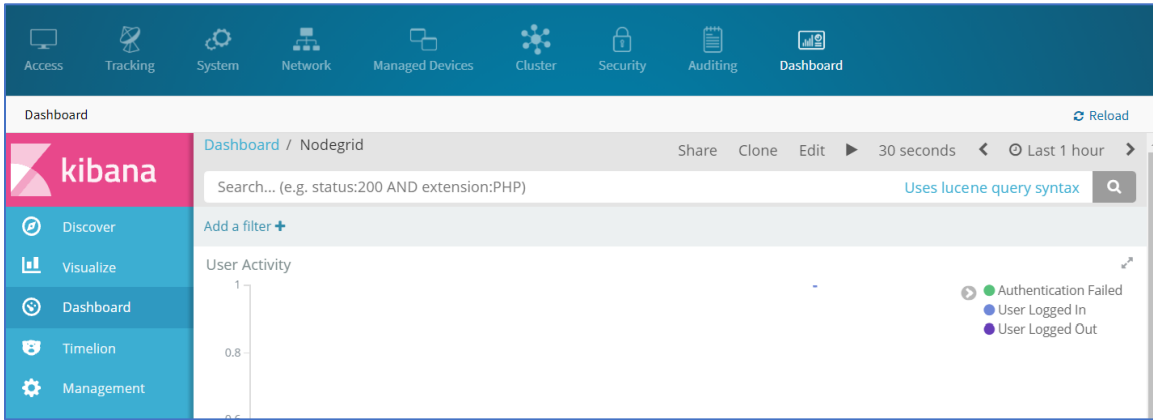

## Manage Dashboards

### Description

#### WebUI Procedure

1. On the left side panel, click **Dashboard** tab (main panel lists saved visualizations).

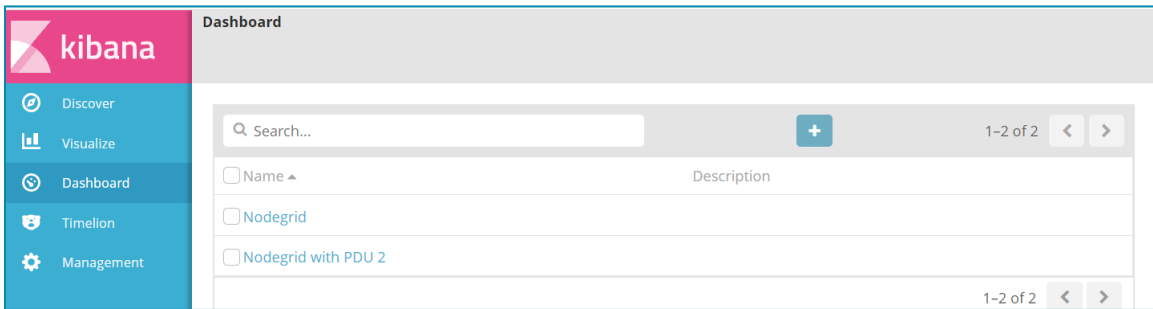

2. On the *Navigation* bar, click the **New Dashboard** icon



3. On the *Editing New Dashboard* panel, click **Add**.

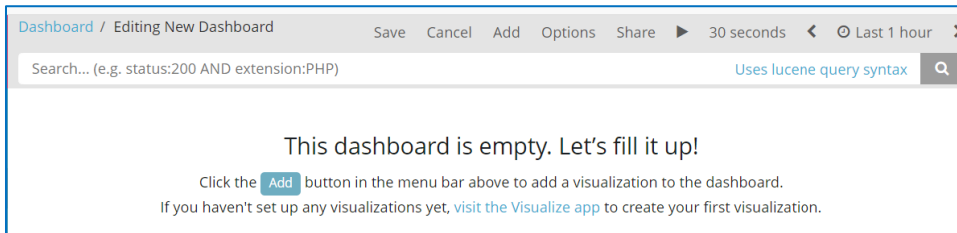

4. On the *Add Panels* dialog, top panel lists available visualizations. To the upper right is the option to create a new visualization. Below is the *dashboard* panel.



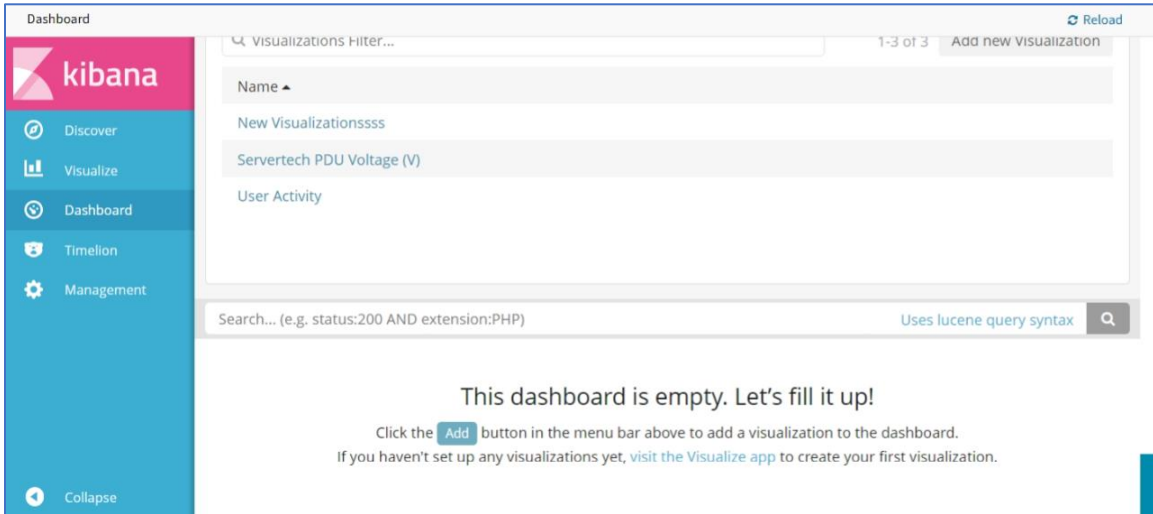

- On the visualization list, click the first one to add. The visualization displays in the *dashboard* panel. Click others to add those to the *dashboard* panel.

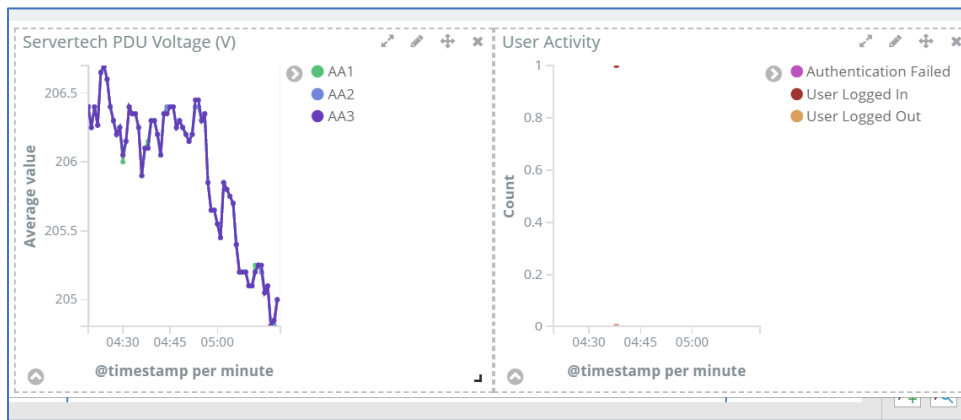

- Resize (lower right corner handle) and reposition (click, drag and drop) the graphs, as needed. .
- If needed, to include a filter, click **Add a filter** (displays *Add a Filter* dialog).

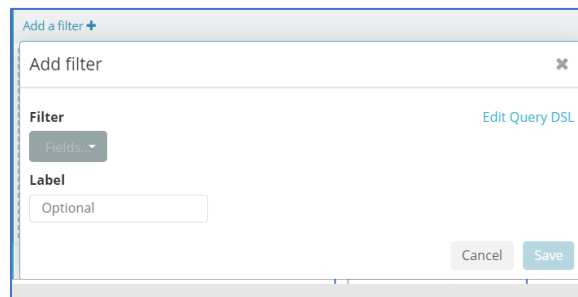

Select from **Filter** drop-down, Enter **Label**, then click **Save**.

- When the dashboard appearance and details are ready, click **Save** icon.

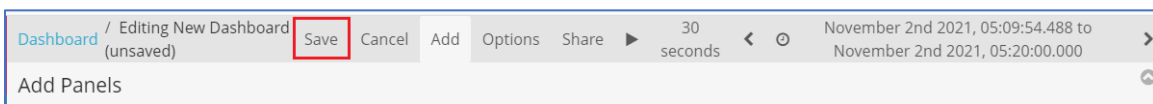

9. On the *Save dashboard* dialog:

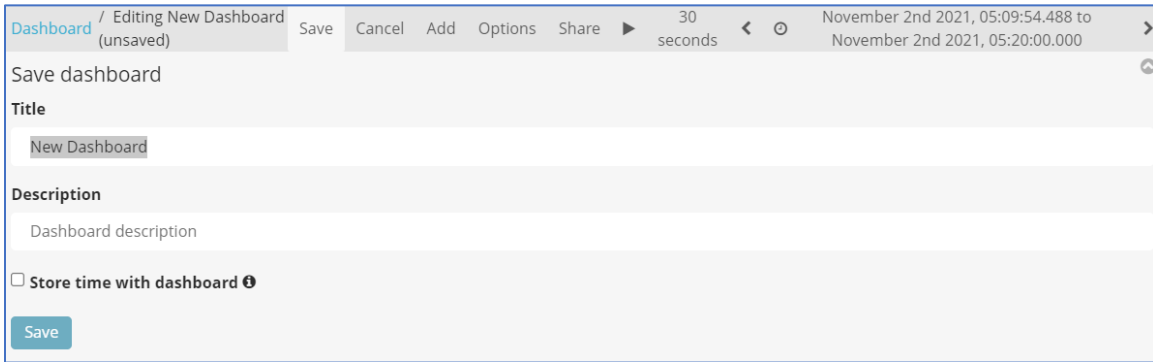

Enter **Title**.

Enter **Description**.

(optional) Select **Store time with dashboard** checkbox.

Click **Save**.

10. The new dashboard is added to the list.

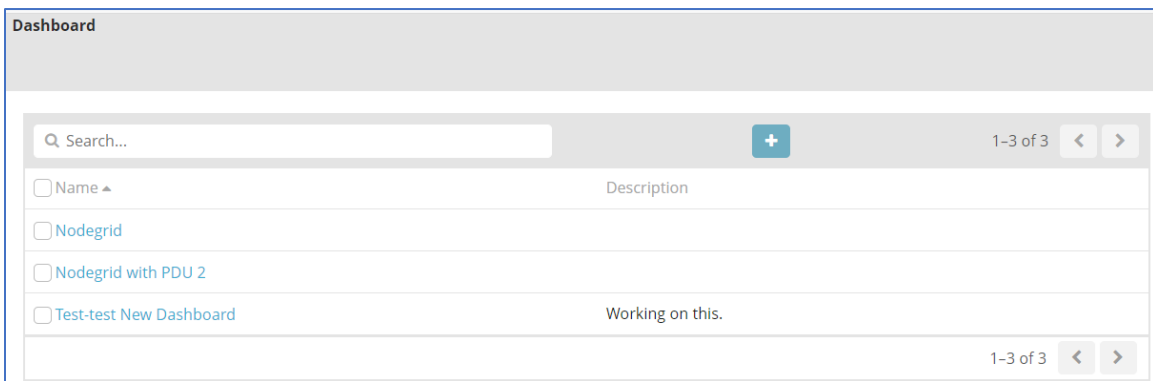

## Timelion tab

This is another visualization tool for time-based data analysis. For example, it can view specific data activity on a timeline basis. The chart results can be analyzed in various time segments (daily, weekly, etc.).

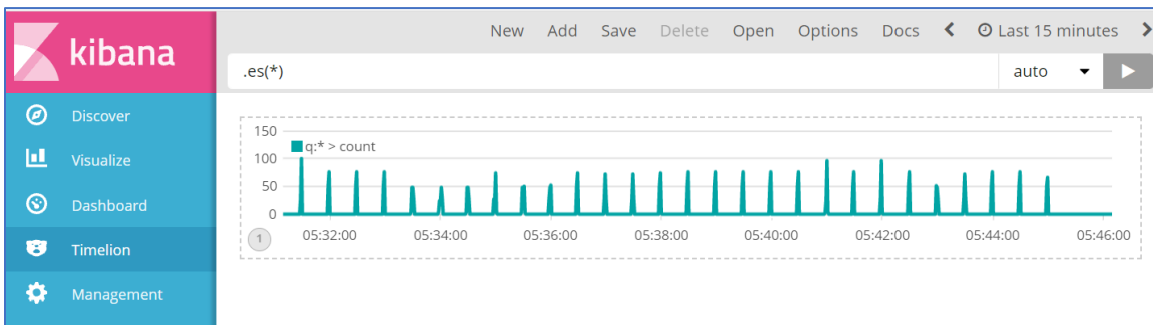

## Toolbar tabs

On the Toolbar, these functions are available:

### New sub-tab

Option to modify the display (change field, change time)

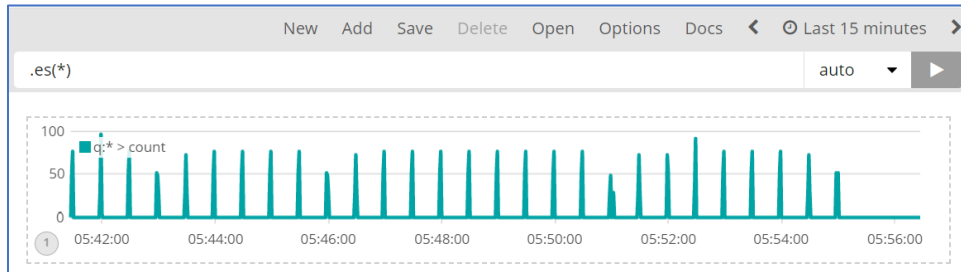

### Add sub-tab

Adds another visualization chart.

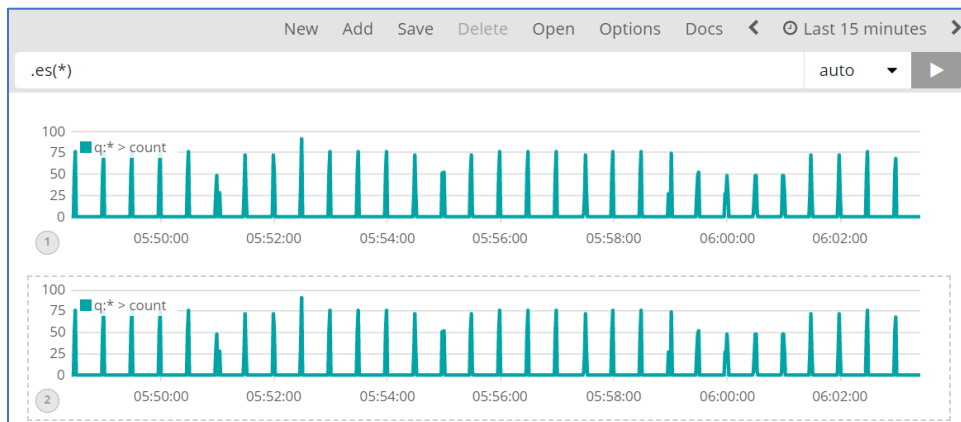

### Save sub-tab

Saves the current configuration. Click on one paragraph, as needed.

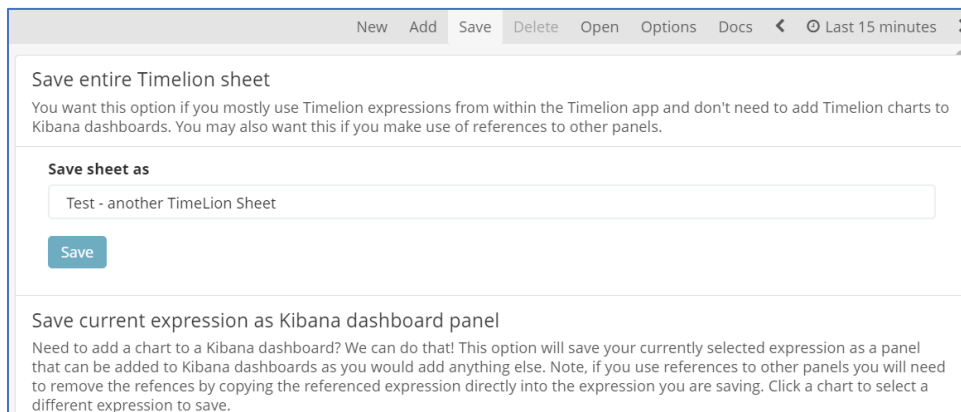

The screenshot shows the 'Save' dialog box with the following content:

- Buttons: New, Add, **Save**, Delete, Open, Options, Docs, Last 15 minutes
- Section: **Save entire Timelion sheet**
- Text: "You want this option if you mostly use Timelion expressions from within the Timelion app and don't need to add Timelion charts to Kibana dashboards. You may also want this if you make use of references to other panels."
- Section: **Save sheet as**
- Input field: "Test - another TimeLion Sheet"
- Button: **Save**
- Section: **Save current expression as Kibana dashboard panel**
- Text: "Need to add a chart to a Kibana dashboard? We can do that! This option will save your currently selected expression as a panel that can be added to Kibana dashboards as you would add anything else. Note, if you use references to other panels you will need to remove the references by copying the referenced expression directly into the expression you are saving. Click a chart to select a different expression to save."

### Delete sub-tab

Displays pop-up dialog to confirm deletion of the current displayed visualization.

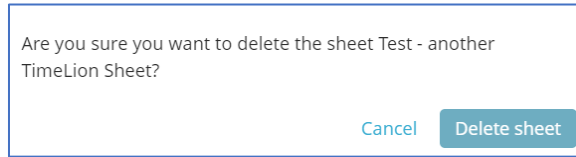

### Open sub-tab

Displays *Open Sheet* dialog to select a visualization.

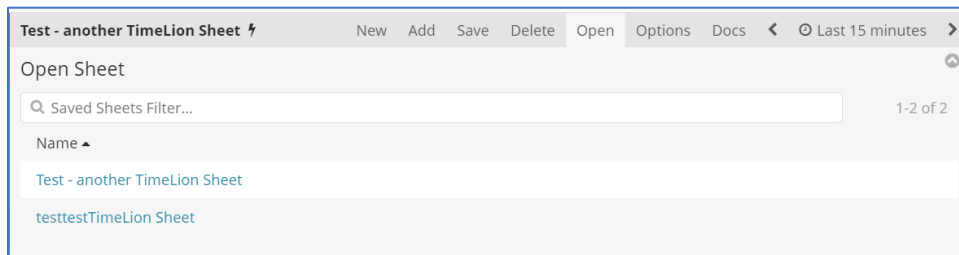

### Options sub-tab

Displays options to modify display of the visualization (Columns, Rows, etc.)

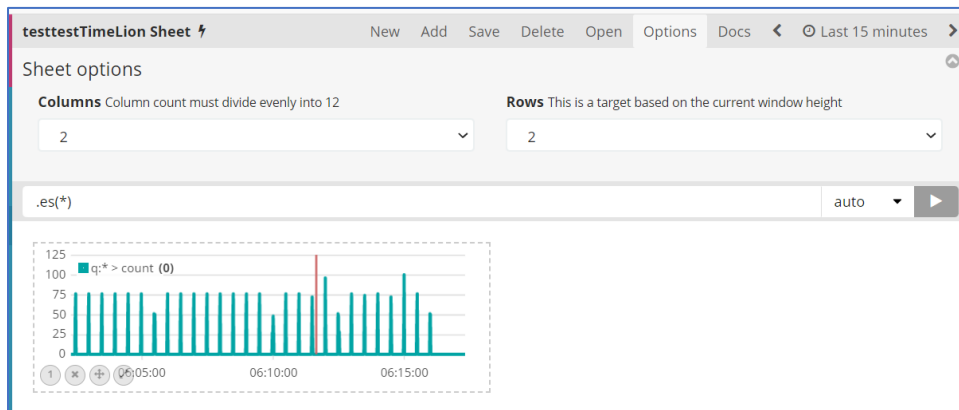

### Docs sub-tab

Displays the Function Reference details.

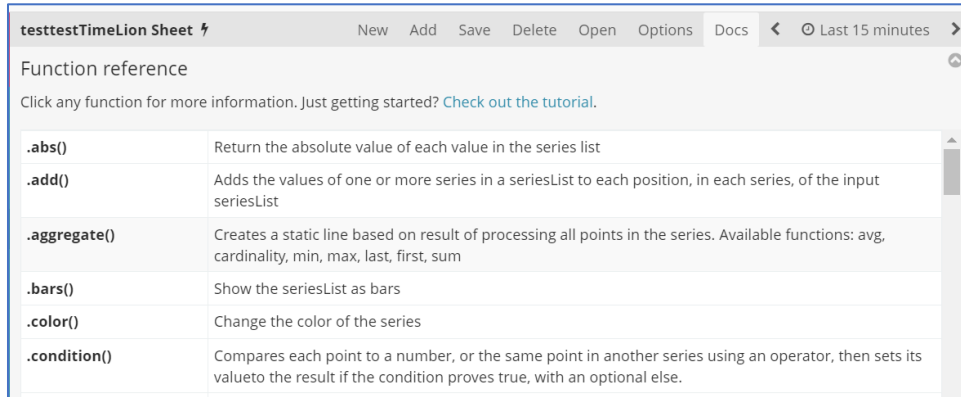

## < (back)

Click to move the display back in time.

## Time Range sub-tab

Option to modify the time range of the visualization.

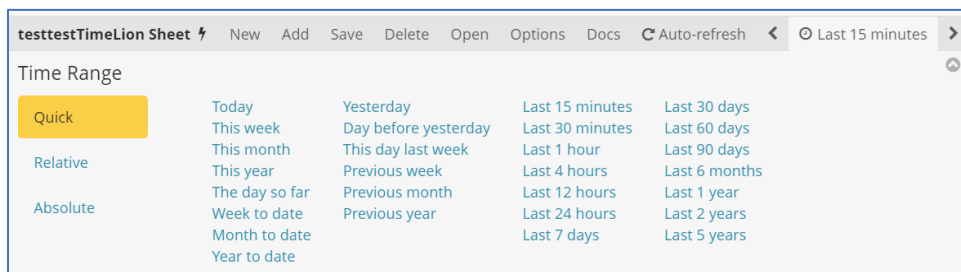

## > (forward)

Click to moves the display forward in time.

## Management tab

This manage index patterns, saved objects. The advanced settings can tweak some points, especially visualizations.

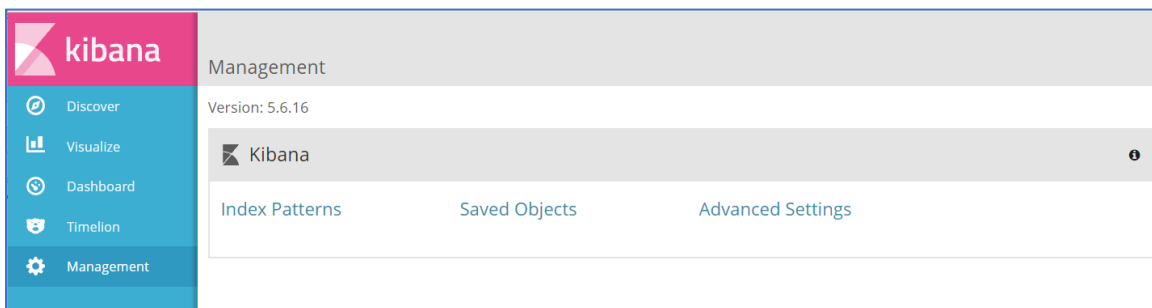

## Index Patterns sub-tab

Displays details of selected index patterns (screenshot shows logstash-\*).

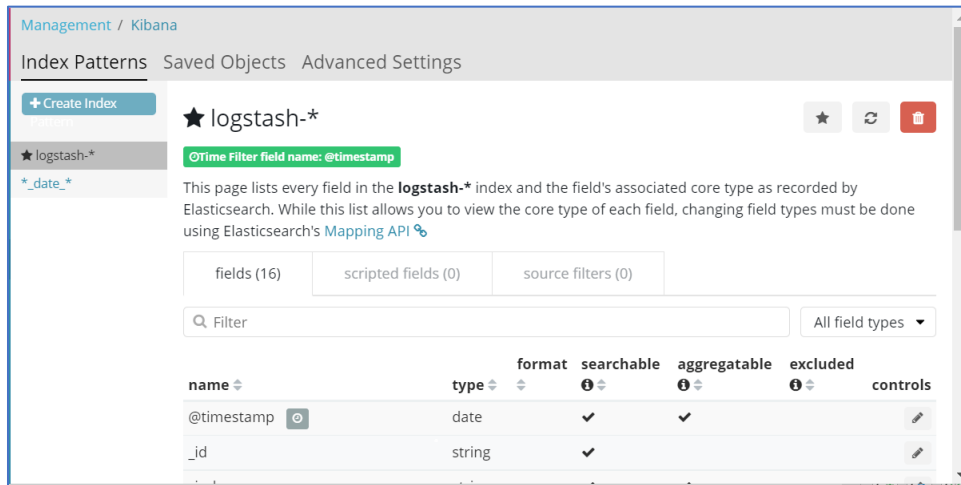

## Saved Objects sub-tab

Displays Edit Saved Objects. To modify, click name on list.

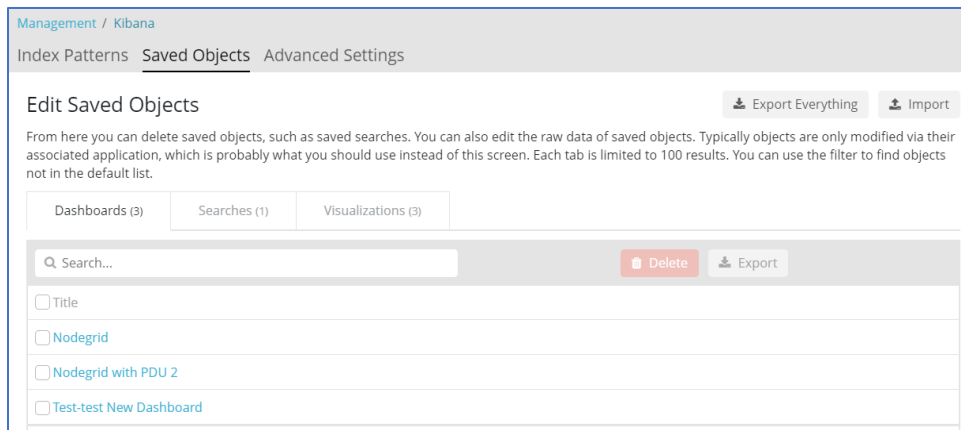

## Advanced Settings sub-tab

Settings can be directly edited here (admin privileges required). Carefully read the **Caution** statement, especially for the size of the history of saved search queries.

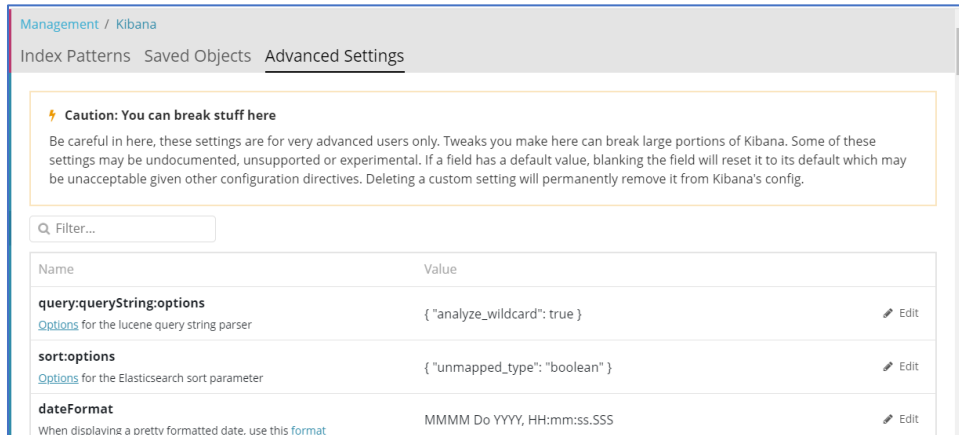

# Applications Section

Nodegrid devices can run additional applications. These provide expanded software capabilities. The most used apps are in the areas of monitoring and SD-WAN. While all Nodegrid units support this feature, the Services Router Family is designed to run applications to enhance a wide variety of connectivity options.

**NOTE:** To run applications, additional licenses are required.

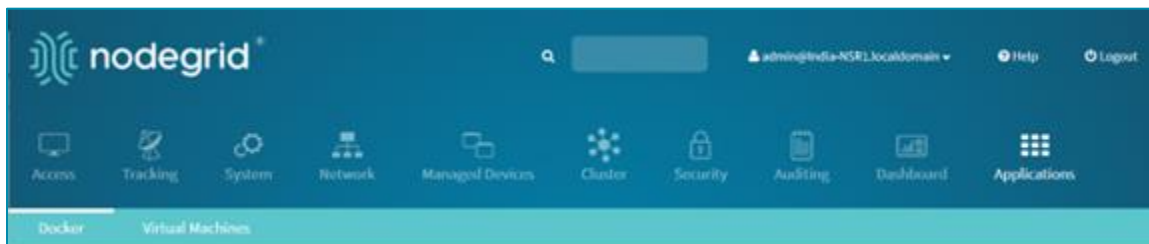

## Docker tab

Docker is an open platform to build, ship and run distributed applications. With Administrator privileges, user can run Docker apps on Nodegrid. Docker applications can be pulled from **Docker Hub**, starting and stopping of the Docker Containers.

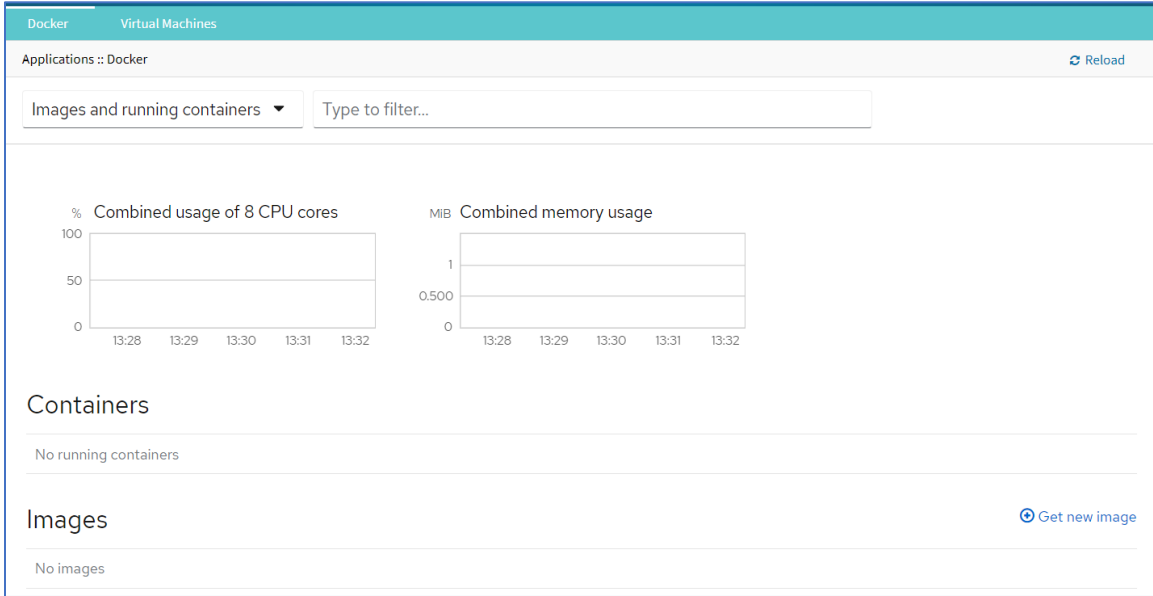

Docker supports Seccomp and Apparmor. New containers are Seccomp and Apparmor enabled by default.

To start a container without Seccomp and Apparmor, the following shell command is required:

```
docker run --name <name> --security-opt seccomp=unconfined --security-opt apparmor=unconfined <image name>.
```

Containers created before v5.4 retain the same behavior prior to this Docker upgrade. For example, if the container was created with the default command, Seccomp and Apparmor is disabled.

## Virtualization

### Activate Virtualization

1. Go to *Security :: Services*
2. In the *Enable Virtualization Services* menu:

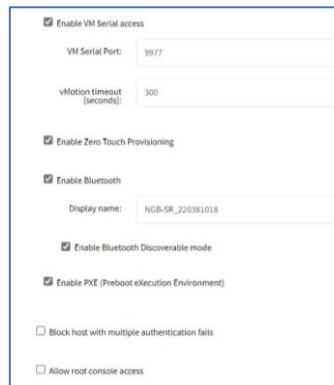
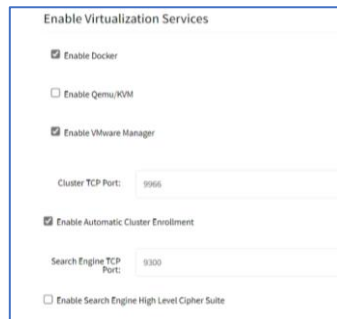

3. Select **Enable Docker** checkbox.



4. Make other settings, as needed
5. Click **Save**.

Licenses are required. To view licensed applications, go to *System :: Licenses*.

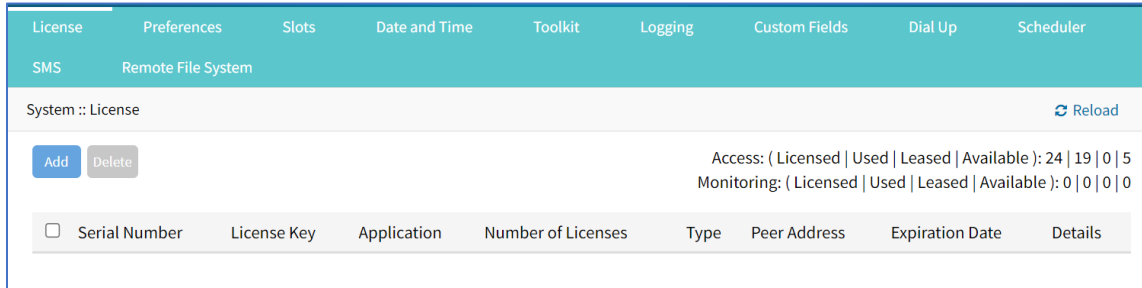

**NOTE:** The management of Docker Applications is currently only available through the WebUI. The WebUI provides a basic interface to manage Docker Containers. For more advanced features, administrators can use the docker command line tools.

## Docker Images

Administrators can directly download images from the Docker Hub to *Applications :: Docker*. The Nodegrid device must have access to the Docker Hub.

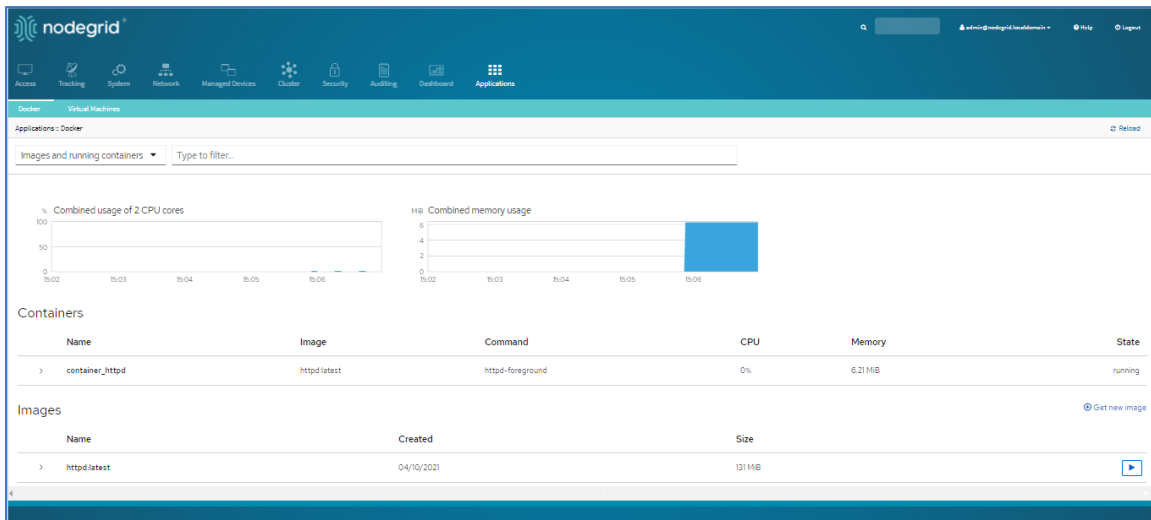

Each container can be configured with several parameters, including exposed ports, memory allocation, environmental variables, name, etc. When a container is created, detailed information is displayed in drop-down menus.

## Add a new Docker Image

**NOTE:** Requires administrator privileges.

### WebUI Procedure

1. Ensure the virtualization license is valid, and device firmware version is 5.4 or later.
2. Go to *Security :: Services* and ensure Docker services are enabled.

3. Go to *Applications :: Docker*.
4. Click **Get new image**.
5. Type **httpd** and press enter
6. On the list, select the image and click **Download**.
7. On download, the image is listed in the *Images* table.

### Add a New Docker Container

1. Select the image and click **Play**.
2. Adjust the configuration details.
3. Click **Run**.

For additional details see the official [Docker create](#) documentation.

**NOTE:** After the container is created, it does not automatically start.

## Virtual Machines tab

On *Applications :: Virtual Machines*, virtual machines can be created, imported, and managed. Within the drop-down menu, an embedded VNC terminal is available and automatically started with the VM.

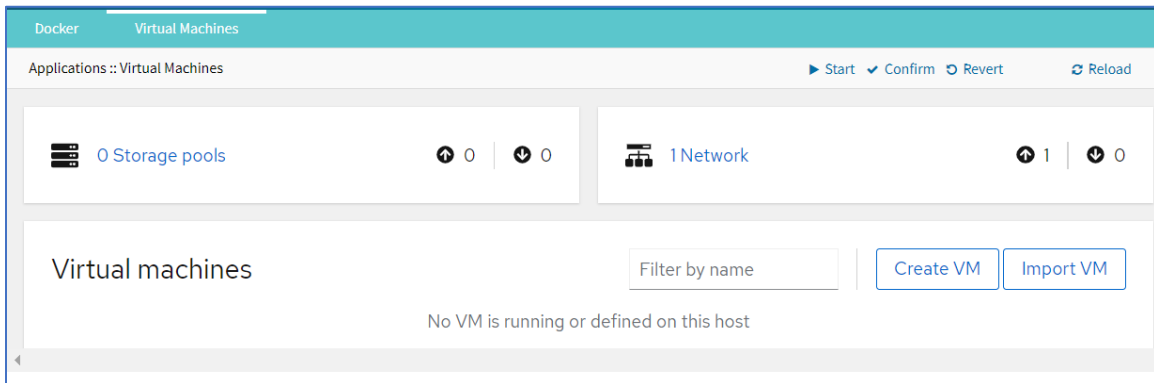

## Storage Pools

### Create a Storage Pool

1. Go to *Applications :: Virtual Machines*.
2. Click **Storage pools** (displays dialog)

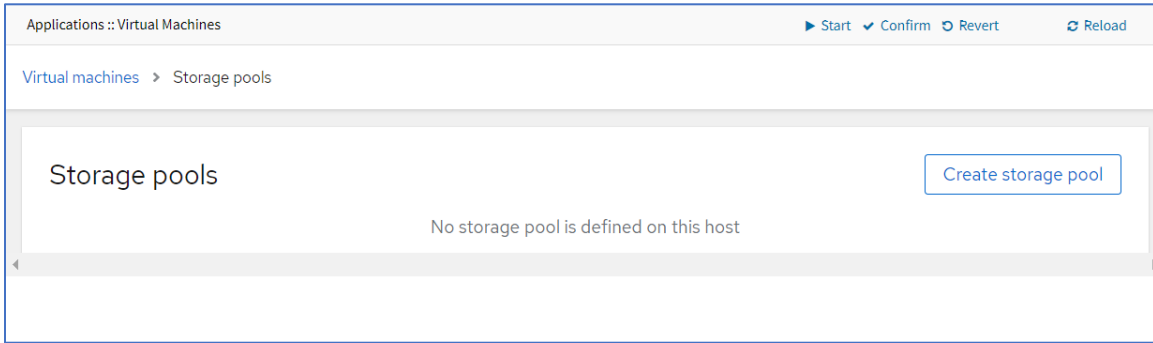

3. Click **Create storage pool** (displays dialog).

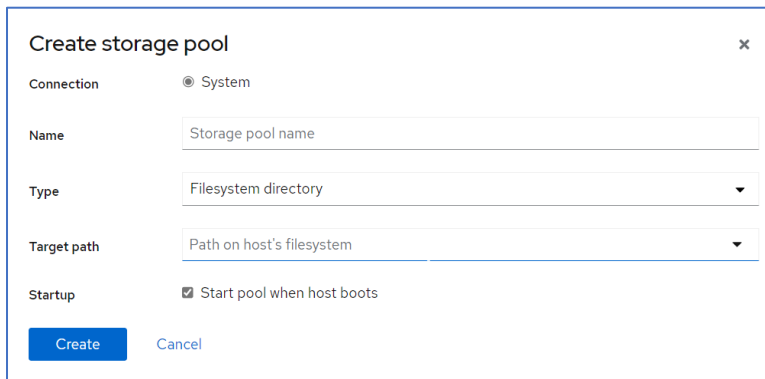

4. Enter **Name**.
5. On **Type** drop-down, select one (**Filesystem directory, Network file system, iSCSI target, Physical disk device, LVM volume group, iSCSI direct target**)

**Filesystem directory**

On **Target path** drop-down, select one (list of file folders).

**Network file system**

On **Target path** drop-down, select one (list of file folders).

Enter **Host** name.

Enter **Source path**

**iSCSI target**

On **Target path** drop-down, select one (list of file folders).

Enter **Host** name.

Enter **Source path**

**Physical disk drive**

On **Target path** drop-down, select one (list of file folders).

Enter **Source path**

On **Format** drop-down, select one (**dos, dvh, gpt, mac**)

**LVM volume group**

Enter **Source volume group**

**iSCSI direct target**

Enter **Host** name.

Enter **Source path**

Enter **Initiator**

6. On **Startup**, select/unselect **Start pool when host boots** checkbox.
7. Click **Create**.

**Create sdb Storage**

*Step 1 – create storage pool*

This is used in the *Access Additional Drive(s)/Drive Partitions* procedure.

1. Go to *Applications :: Virtual Machines*.
2. Click **Storage pools** (displays dialog)
3. Click **Create storage pool** (displays dialog).
4. Enter **Name**.
5. On **Type** drop-down, select **Filesystem directory**
6. On **Target path** field, enter:  
`/var/local/file_manager/admin_group/sdb1/`
7. On **Startup**, select/unselect **Start pool when host boots** checkbox.
8. Click **Create** (displays dialog).

Storage pools				Create storage pool
Name	Size	Connection	State	
> Test_storage	<div style="width: 100px; height: 10px; background-color: #add8e6;"></div>	0 / 0 GiB	System	inactive

*Step 2 – Create Volume*

1. Expand the details (click > arrow – left side)

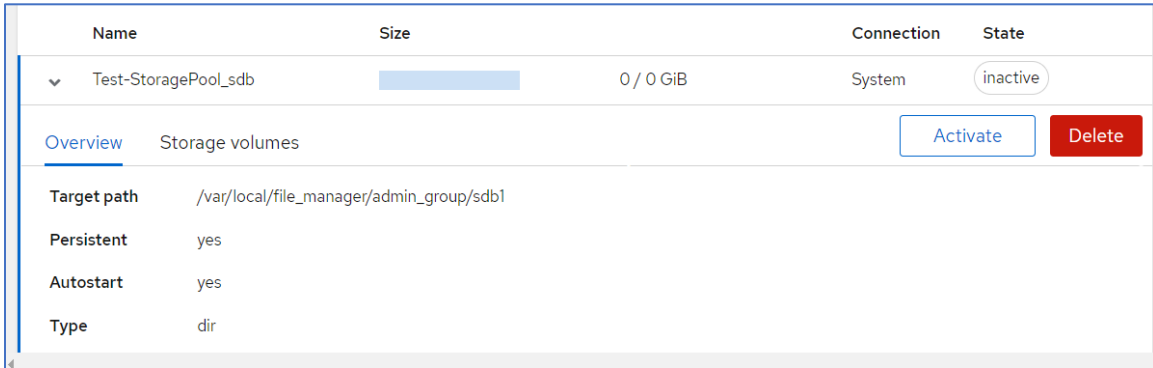

2. Click **Activate**.
3. On *Storage volumes* sub-tab, click **Create a Volume**.  
 Enter **Name**  
 Enter **Size**. On drop-down, select **Gib** or **MiB**.  
 On **Format** drop-down, select one (**qcow2**, **raw**).
4. Click **Create**.

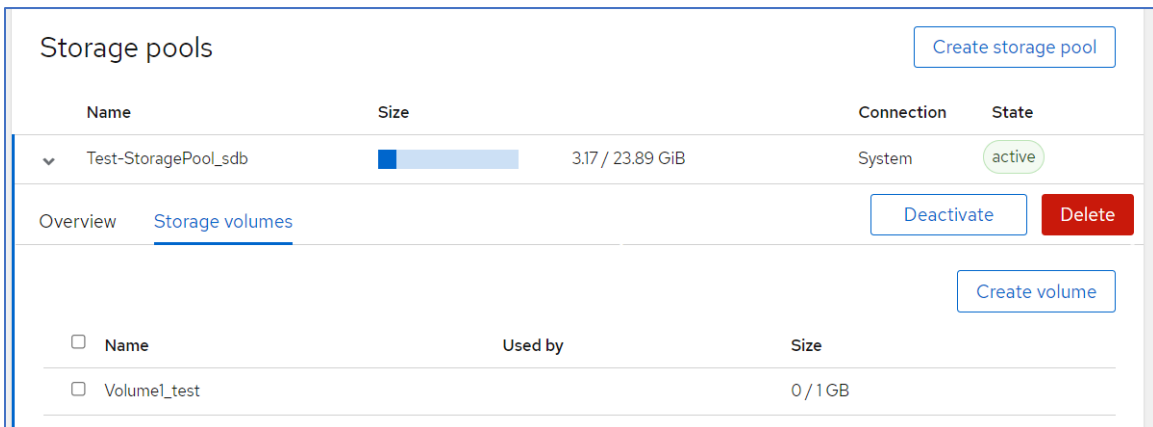

**Step 3 – Create Virtual Machine**

1. On *Virtual Machine* page, go to *Virtual machines* section:

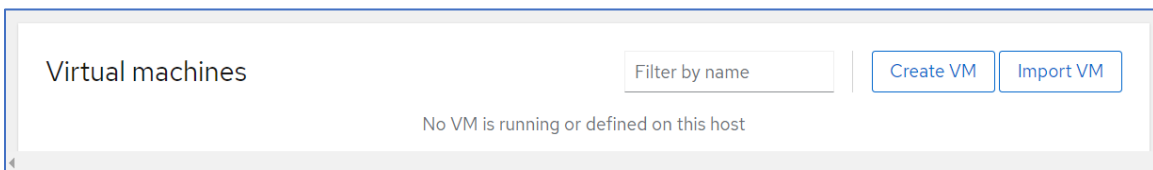

2. Click **Create VM** (displays dialog).

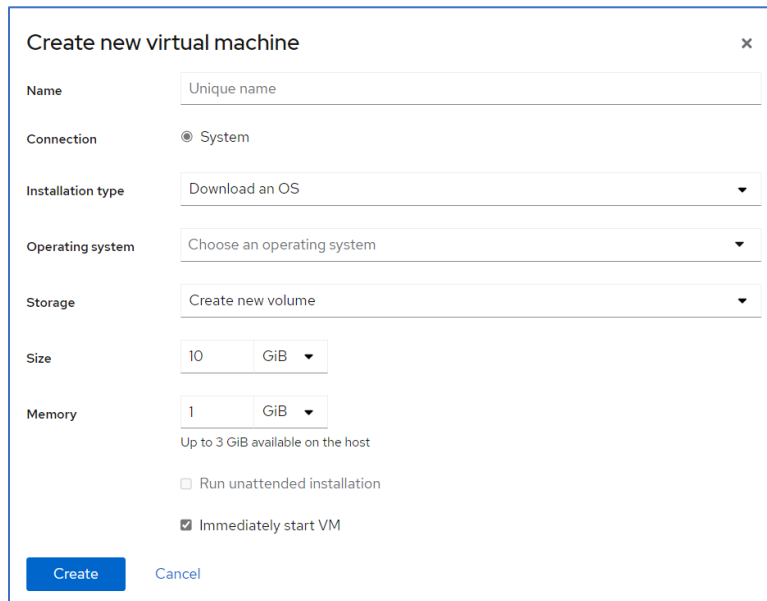

3. Enter **Name**
4. On **Installation type** drop-down, select one (
  - Download an OS**
  - Cloud base storage**
    - On **Installation source**, select from drop-down (or enter the path).
    - Local install media (ISO image or distro install tree)**
      - On **Installation source**, enter the path to ISO file on host file system.
      - URL (ISO image or distro install tree)**
        - On **Installation source**, enter remote URL.
      - Network boot (PXE)**
        - On **Installation source** drop-down, select one (selection may include a warning note).
5. On **Operating system** drop-down, select one (depends on **Installation type** selection).
6. ON **Storage** drop-down, select the sdb storage pool.
7. On **Volume** drop-down, select the sdb volume.
8. On **Memory**, make changes as needed.
9. (if available) Select **Run unattended installation** checkbox.
10. Select **Immediately start VM** checkbox.
11. Click **Create**.

## Networks

### Create a Network

1. Go to *Applications :: Virtual Machines*.
2. Click **Network** (displays dialog)

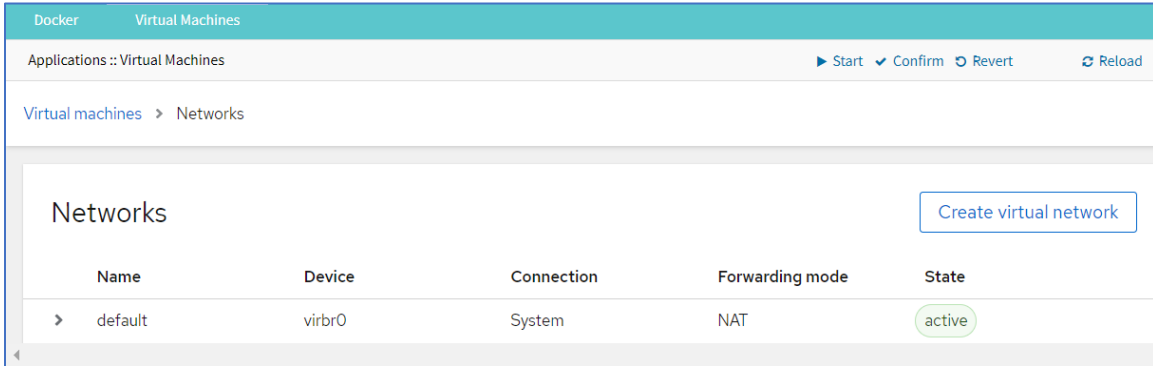

3. Click Create virtual network (displays dialog).

**Create virtual network** ✕

Connection: system

Name:

Forward mode:  ▼

Device:  ▼

IP configuration:  ▼

IPv4 address:

Mask or prefix length:

Set DHCP range

Create Cancel

4. Enter **Name**
5. On **Forward** mode drop-down, select one (**NAT, Open, None (isolated network)**).

#### NAT

On **Device** drop-down, select one (list of options).

#### Open

#### None (isolated network)

6. On **IP configuration** drop-down, select one (**IPv4 only, IPv6 only, IPv4 and IPv6**).

#### IPv4 only

IPv4 address	192.168.100.1		
Mask or prefix length	24		
	<input checked="" type="checkbox"/> Set DHCP range		
Start	<input type="text"/>	End	<input type="text"/>

Enter **IPv4 address**

Enter **Mask or prefix length**

Select **DHCP range** checkbox

Enter **Start**

Enter **End**

### IPv6 only

IPv6 address	<input type="text"/>		
Prefix length	<input type="text"/>		
	<input checked="" type="checkbox"/> Set DHCP range		
Start	<input type="text"/>	End	<input type="text"/>

Enter **IPv6 address**

Enter **Prefix length**

Select **DHCP range** checkbox

Enter **Start**

Enter **End**

### IPv4 and IPv6

IPv4 address	192.168.100.1		
Mask or prefix length	24		
	<input checked="" type="checkbox"/> Set DHCP range		
Start	<input type="text"/>	End	<input type="text"/>
IPv6 address	<input type="text"/>		
Prefix length	<input type="text"/>		
	<input checked="" type="checkbox"/> Set DHCP range		
Start	<input type="text"/>	End	<input type="text"/>

Enter **IPv4 address**

Enter **Mask or prefix length**



Select **DHCP range** checkbox

Enter **Start**

Enter **End**

Enter **IPv6 address**

Enter **Prefix length**

Select **DHCP range** checkbox

Enter **Start**

Enter **End**

7. Click **Create**.

## Libvirt VM Tool

### Create a new VM via Libvirt

1. Copy the .iso image to /var/lib/libvirt/images
2. Go to *Applications :: Virtual Machines*.
3. Click **Create VM** (displays dialog).

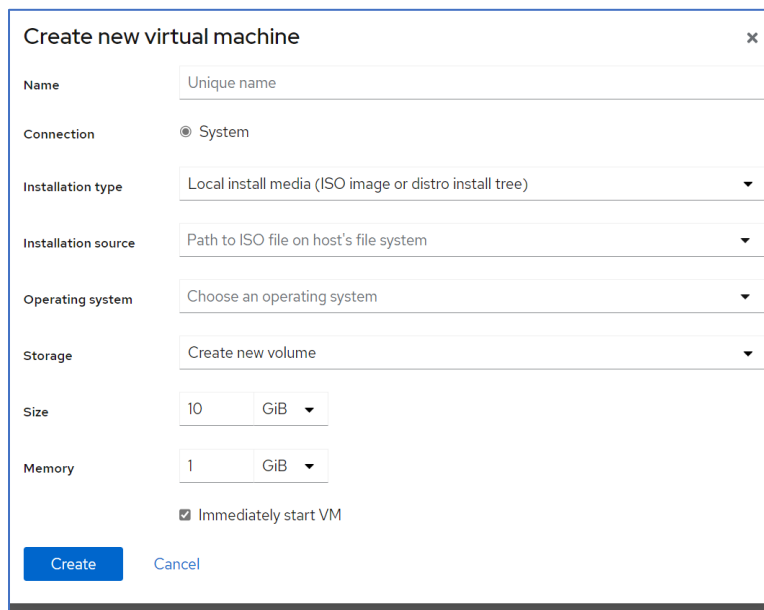

4. Enter Name.
5. On **Installation Type** drop-down, select **Local install media (ISO image or distro install tree)**. Other options: **URL (ISO image or distro install tree)**, **Network boot (PXE)**.
6. Enter **Installation Source** (options adjust based on **Installation Type** selection).
7. On **Operating System** drop-down, select one (if available).
8. On **Storage** drop-down, select one (**Create new volume**, **No storage**, **Storage pools**).

If **Create new volume** selected, enter **Size** and **Memory**.

9. Select **Immediately Start VM** checkbox.
10. Click **Create**.

## WiFi Controller tab

This provides information on Devices, Firmware and System.

### *Install OpenWiFi*

#### Get OpenWiFi Script

To get the OpenWiFi install package, contact [Technical Support](#).

#### Install OpenWiFi Script

11. Copy the package to the Nodegrid device (any location is acceptable).
12. Open Shell SUDO.
13. To make it executable:  

```
chmod +x <package_file>
```
14. To execute:  

```
./<package_file>
```
15. To view the OpenWiFi application, go to *Applications :: WiFi Controller*.

#### Enable/Disable WiFi Controller

16. Go to *Security :: Services*.
17. In *Active Services* menu:  
Select/unselect **Enable WiFi Controller** checkbox.
18. Click **Save**.

## Applications :: WiFi Controller :: Gateway

### Devices side-tab

Go to Applications :: WiFi Controller :: Gateway – Devices :: Dashboard.

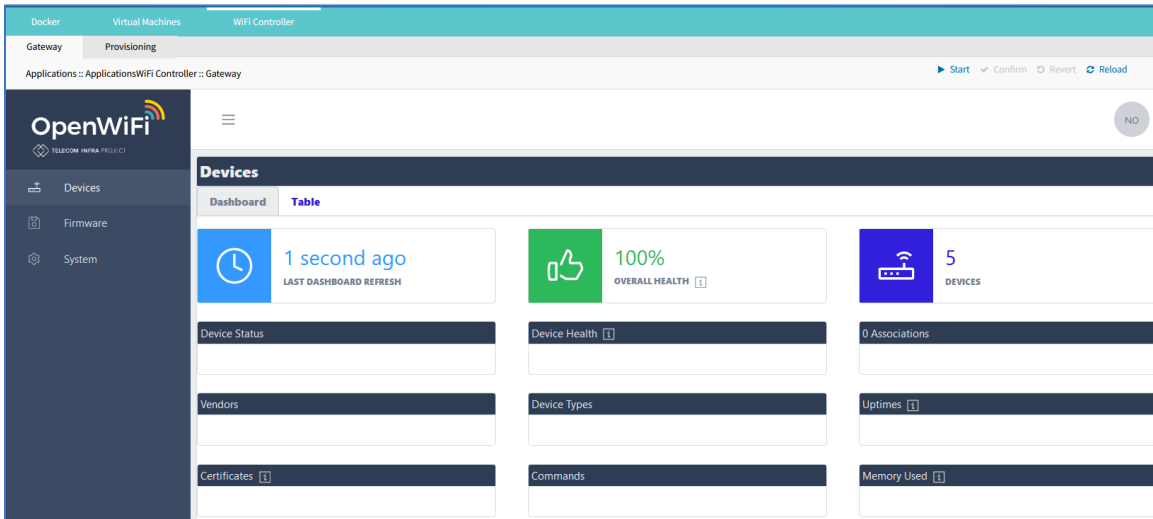



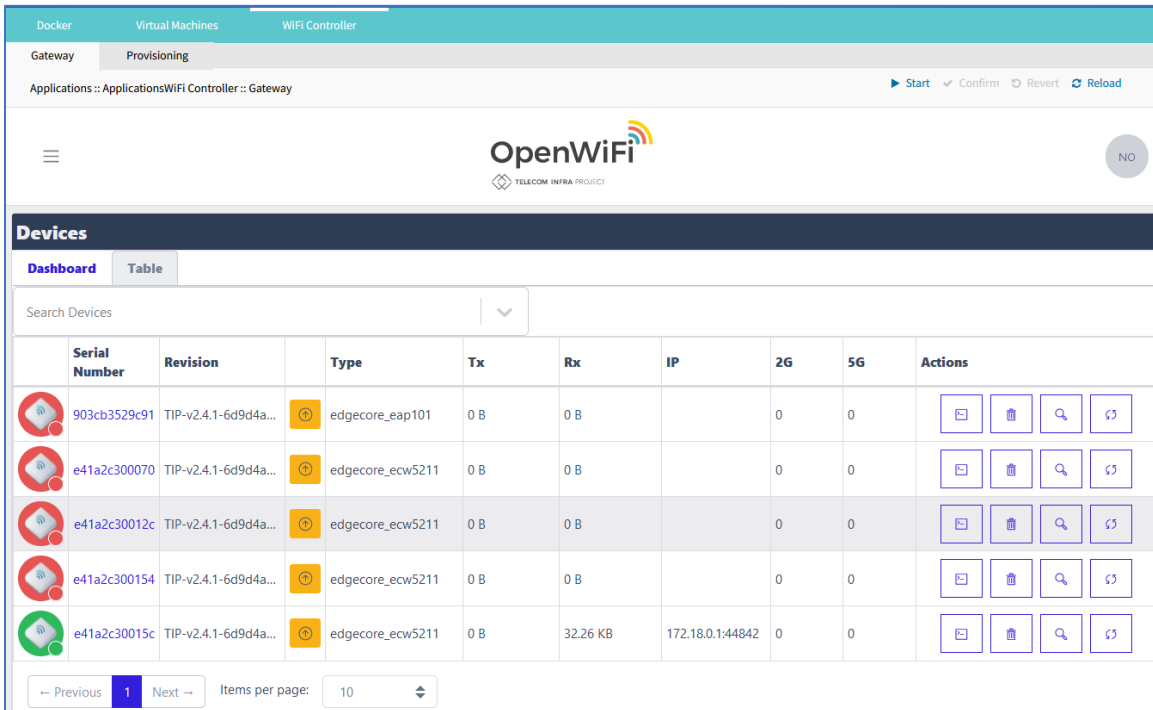

Go to Applications :: WiFi Controller :: Gateway – Devices :: Table.

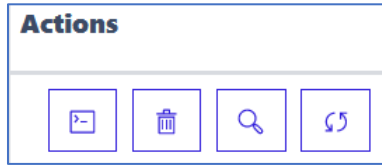

On the Actions column, click buttons, as needed.



-  Connect this device
-  Delete this device.
-  Display details on this device.
-  Refresh this device.

### Firmware side-tab

Go to *Applications :: WiFi Controller :: Gateway – Firmware ::Dashboard.*

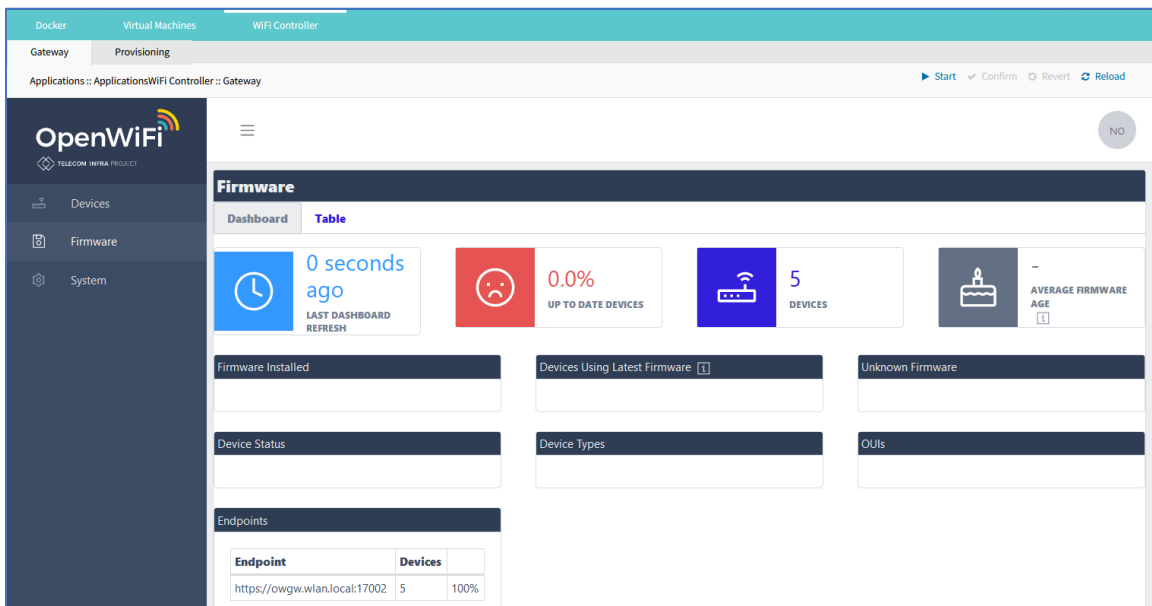

The screenshot displays the OpenWiFi Firmware Dashboard. The top navigation bar includes 'Gateway' and 'Provisioning' tabs. The main content area features several key metrics:

- Refresh:** 0 seconds ago (LAST DASHBOARD REFRESH)
- Update Status:** 0.0% UP TO DATE DEVICES
- Device Count:** 5 DEVICES
- Average Firmware Age:** -

Below these metrics are several summary cards:

- Firmware Installed:** (Empty card)
- Devices Using Latest Firmware:** (Empty card)
- Unknown Firmware:** (Empty card)
- Device Status:** (Empty card)
- Device Types:** (Empty card)
- OUIs:** (Empty card)

At the bottom, there is an 'Endpoints' table:

Endpoint	Devices	
https://owgw.wlan.local:17002	5	100%

Go to *Applications :: WiFi Controller :: Gateway – Firmware :: Table.*

Image Date	Size	Revision	URI
2022-11-04 12:29:15	10.54 MB	TIP-v2.7.2-b677669	<a href="https://uccentral-ap-firmware.s3.amazonaws.com/20221104-actiontec_web7200-v2.7.2-b677669-upgrade.bin">https://uccentral-ap-firmware.s3.amazonaws.com/20221104-actiontec_web7200-v2.7.2-b677669-upgrade.bin</a>
2022-11-02 14:42:11	10.54 MB	TIP-v2.7.2-rc2-6ce868a	<a href="https://uccentral-ap-firmware.s3.amazonaws.com/20221102-actiontec_web7200-v2.7.2-rc2-6ce868a-upgrade.bin">https://uccentral-ap-firmware.s3.amazonaws.com/20221102-actiontec_web7200-v2.7.2-rc2-6ce868a-upgrade.bin</a>
2022-11-01 15:44:18	10.54 MB	TIP-v2.7.2-rc1-05e2b63	<a href="https://uccentral-ap-firmware.s3.amazonaws.com/20221101-actiontec_web7200-v2.7.2-rc1-05e2b63-upgrade.bin">https://uccentral-ap-firmware.s3.amazonaws.com/20221101-actiontec_web7200-v2.7.2-rc1-05e2b63-upgrade.bin</a>
2022-10-19 18:58:05	10.54 MB	TIP-v2.7.1-25d7b9d	<a href="https://uccentral-ap-firmware.s3.amazonaws.com/20221020-actiontec_web7200-v2.7.1-25d7b9d-upgrade.bin">https://uccentral-ap-firmware.s3.amazonaws.com/20221020-actiontec_web7200-v2.7.1-25d7b9d-upgrade.bin</a>
2022-10-19 10:01:38	10.54 MB	TIP-v2.7.1-rc2-25d7b9d	<a href="https://uccentral-ap-firmware.s3.amazonaws.com/20221019-actiontec_web7200-v2.7.1-rc2-25d7b9d-upgrade.bin">https://uccentral-ap-firmware.s3.amazonaws.com/20221019-actiontec_web7200-v2.7.1-rc2-25d7b9d-upgrade.bin</a>
2022-10-10 11:15:06	10.54 MB	TIP-v2.7.1-rc1-26391d3	<a href="https://uccentral-ap-firmware.s3.amazonaws.com/20221010-actiontec_web7200-v2.7.1-rc1-26391d3-upgrade.bin">https://uccentral-ap-firmware.s3.amazonaws.com/20221010-actiontec_web7200-v2.7.1-rc1-26391d3-upgrade.bin</a>
2022-10-04 23:45:00	10.53 MB	TIP-v2.7.0-9ea3e4c	<a href="https://uccentral-ap-firmware.s3.amazonaws.com/20221005-actiontec_web7200-v2.7.0-9ea3e4c-upgrade.bin">https://uccentral-ap-firmware.s3.amazonaws.com/20221005-actiontec_web7200-v2.7.0-9ea3e4c-upgrade.bin</a>
2022-09-26 16:25:25	10.53 MB	TIP-v2.7.0-rc2-9ea3e4c	<a href="https://uccentral-ap-firmware.s3.amazonaws.com/20220926-actiontec_web7200-v2.7.0-rc2-9ea3e4c-upgrade.bin">https://uccentral-ap-firmware.s3.amazonaws.com/20220926-actiontec_web7200-v2.7.0-rc2-9ea3e4c-upgrade.bin</a>
2022-09-09 15:04:21	10.52 MB	TIP-v2.7.0-rc1-dc2feb3	<a href="https://uccentral-ap-firmware.s3.amazonaws.com/20220909-actiontec_web7200-v2.7.0-rc1-dc2feb3-upgrade.bin">https://uccentral-ap-firmware.s3.amazonaws.com/20220909-actiontec_web7200-v2.7.0-rc1-dc2feb3-upgrade.bin</a>

Copy this URI to clipboard.

Display details on this URI.

### System side-tab

Go to *Applications :: WiFi Controller :: Gateway – System.*

**owsec**

Endpoint: /openwifi/sec  
 Host Name: c020d046a970  
 Operation System: Linux  
 Processors: 4  
 Start: 5 days ago  
 Uptime: 5 days, 1 hour, 45 minutes, 1 second  
 Version: 2.4.0(109) - v2.4.0  
 Certificates: [Details \(1\)](#)  
 Reload:

**owprov**

Endpoint: /openwifi/provisioning  
 Host Name: 2bca45265622  
 Operation System: Linux  
 Processors: 4  
 Start: 5 days ago  
 Uptime: 5 days, 1 hour, 44 minutes, 59 seconds  
 Version: 2.5.0(139) - v2.5.0  
 Certificates: [Details \(1\)](#)  
 Reload:

**owgw**

Endpoint: /openwifi/gateway  
 Host Name: d89d718fed67  
 Operation System: Linux  
 Processors: 4  
 Start: 5 days ago  
 Uptime: 5 days, 1 hour, 45 minutes, 1 second  
 Version: 2.4.0(44) - v2.4.0  
 Certificates: [Details \(2\)](#)  
 Reload:

**owfms**

Endpoint: /openwifi/firmware  
 Host Name: 7552de44c4e8  
 Operation System: Linux  
 Processors: 4  
 Start: 5 days ago  
 Uptime: 5 days, 1 hour, 44 minutes, 56 seconds  
 Version: 2.4.0(32) - v2.4.0  
 Certificates: [Details \(1\)](#)  
 Reload:

Certificates: [Details \(2\)](#)

Reload:

Click **Details** link to display Certificate details.

Expires On	Filename
2025-07-08 03:49:15	websocket-cert.pem
2031-09-20 03:31:16	restapi-cert.pem

To reload, on **Select** drop-down, select one, then click Refresh icon.





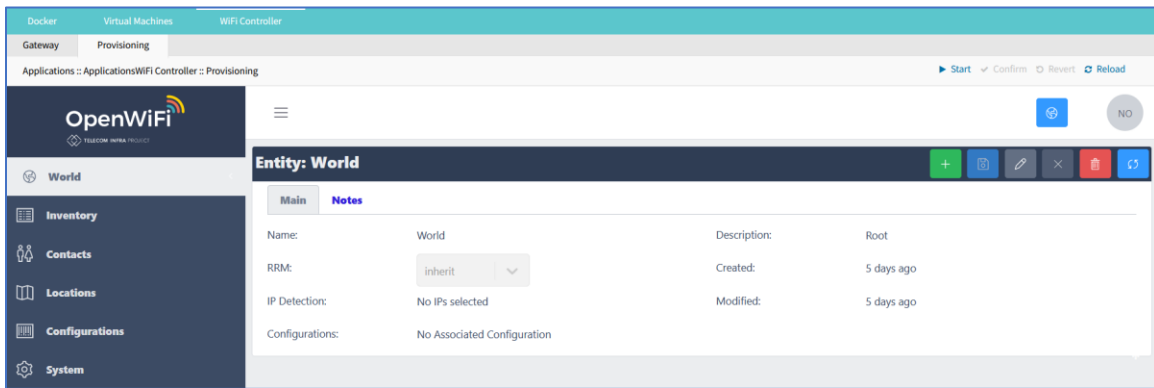

## Applications :: WiFi Controller :: Provisioning

### World side-tab

Go to *Applications :: WiFi Controller :: Provisioning – World :: Main*.



Buttons:

-  Add Child Entity to World
-  Save
-  Edit
-  Close window
-  Delete
-  Refresh

## Inventory side-tab

Go to *Applications :: WiFi Controller :: Positioning – Inventory*.

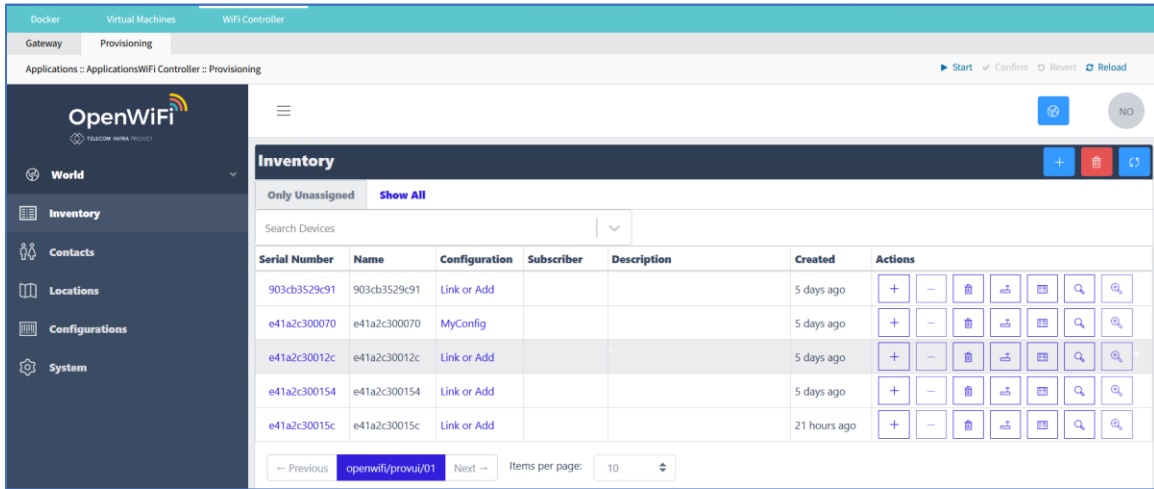

## Contacts side-tab

Go to *Applications :: WiFi Controller :: Positioning – Contacts*.

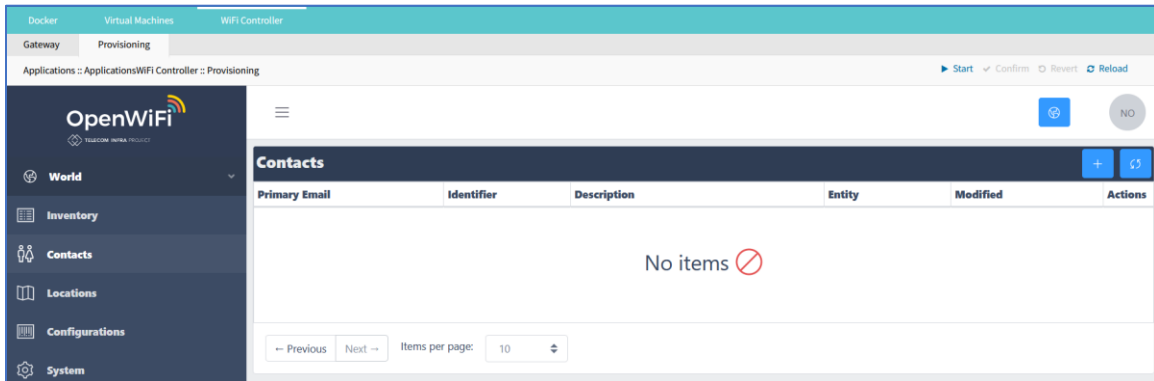

## Locations side-tab

Go to *Applications :: WiFi Controller :: Positioning – Locations*.

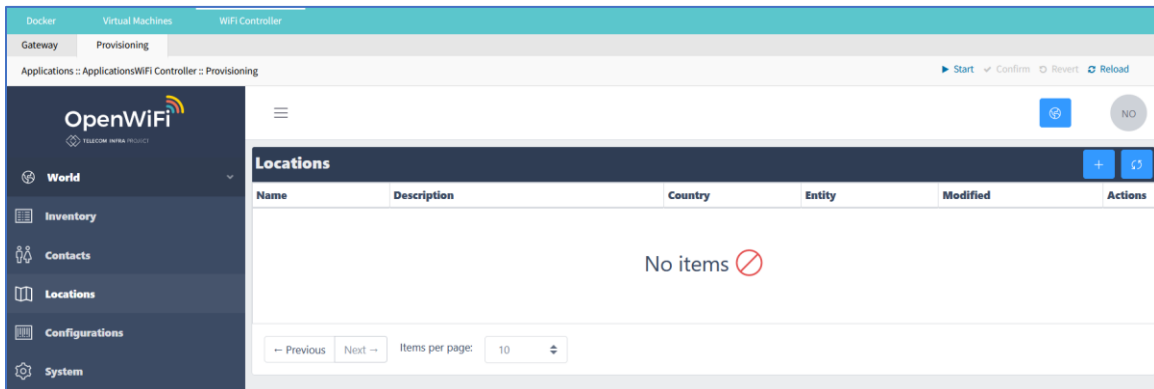

## Configurations side-tab

Go to *Applications :: WiFi Controller :: Positioning – Configurations.*

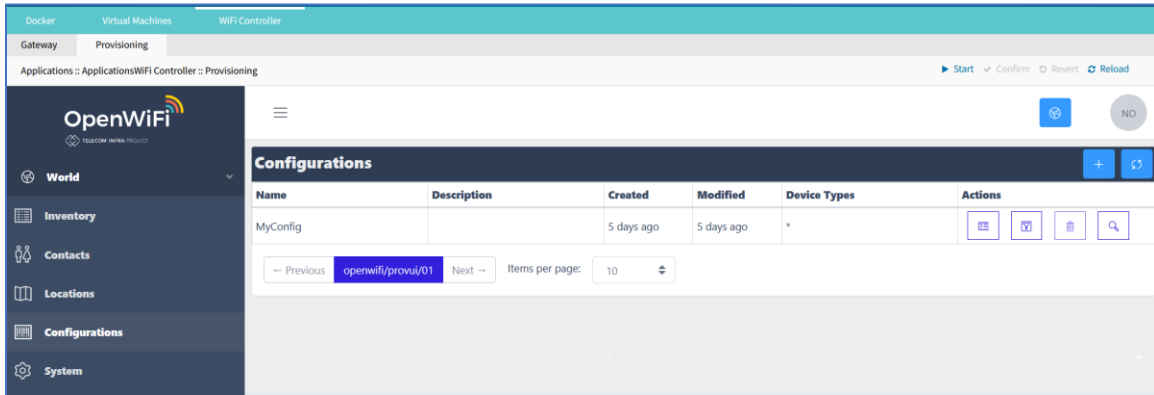

## System side-tab

Go to *Applications :: WiFi Controller :: Positioning – System.*

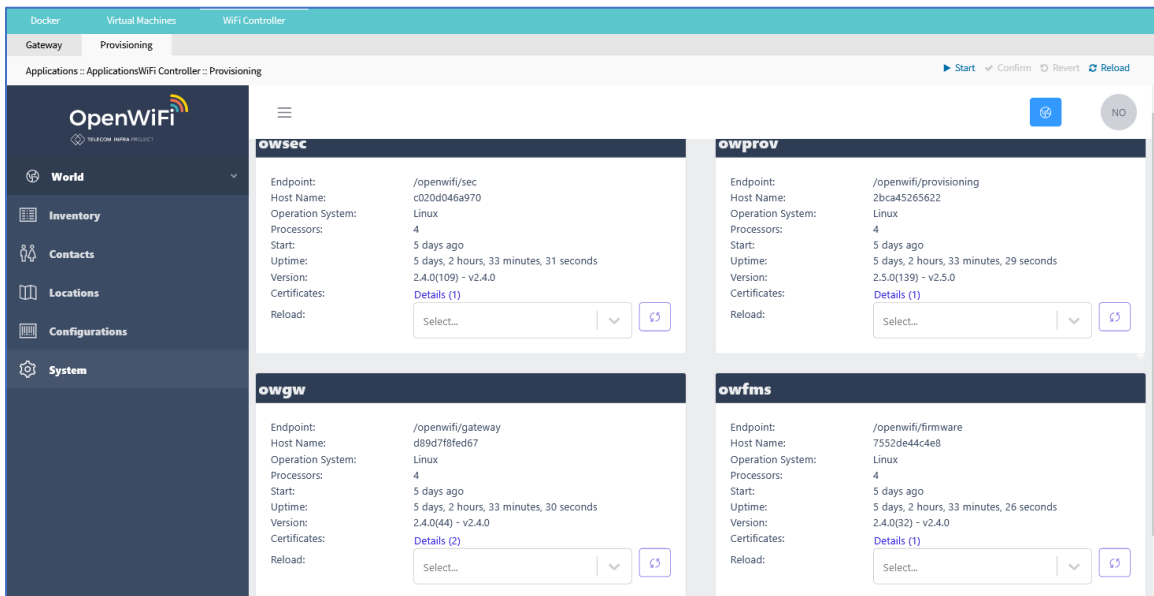

## Network Function Virtualization

Administrators can run additional NFV's or other Virtual Machines. A large variety of configuration options is available through the command line interface.

Contact [Technical Support](#) for more information.



# Appendix A – General Information

## Technical Support

Our Technical Support staff provides assistance in any operational or installation issues for the Nodegrid products. For any question first follow this procedure:

1. From the Device WebUI, open the device help. Based on the WebUI location of the situation, go to the document location for that feature/function.
2. Check the Online help documentation at [www.zpesystems.com/support](http://www.zpesystems.com/support)
3. (admin privileges only) Access the <https://<Nodegrid URL>/services/status>.

Enter the login credentials.

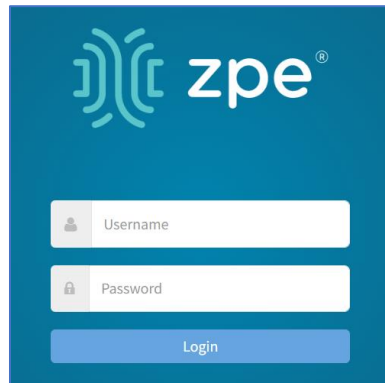

The image shows a login form for the zpe system. It features the zpe logo at the top left. Below the logo are two input fields: one for 'Username' and one for 'Password'. A blue 'Login' button is positioned below the password field.

On the *Status* page, review contents.

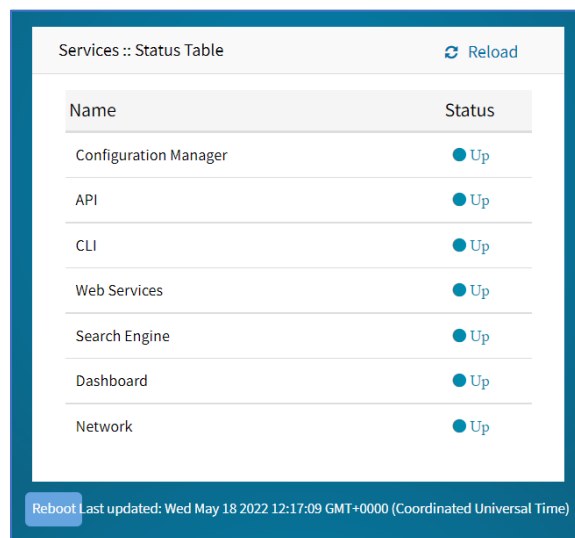

The image shows a screenshot of the 'Services :: Status Table' page. The table lists various services and their status. All services are shown as 'Up' with a green dot indicator. At the bottom of the table, there is a 'Reboot' button and a timestamp: 'Last updated: Wed May 18 2022 12:17:09 GMT+0000 (Coordinated Universal Time)'.

Name	Status
Configuration Manager	● Up
API	● Up
CLI	● Up
Web Services	● Up
Search Engine	● Up
Dashboard	● Up
Network	● Up

As needed, check the Knowledge Base or submit a Support Tickets.

+++++

To enable/disable access, go to: *Security :: Services*. In *Active Services* menu, select/unselct:

**Enable Services Status Page** checkbox (default: enabled)

(as needed) **Enable reboot on Service Status Page** checkbox (default: enabled)

+++++

4. Visit our [Help Center Website](#) for the Knowledge Base and other useful links.

## Support Ticket

### Submit an online ticket request

1. At the top-right of the WebUI, click **Submit a request**.
2. In the form, enter the required information. Provide as much detailed information as possible on the description of the problem or question.
3. If needed, a file or graphic image can be attached.
4. Select the **I'm not a robot** checkbox.
5. Click **Submit**.

A response email will be sent to you from ZPE Systems that confirms your request was received. The email includes the Support Ticket Number. This is needed as reference.

## Updates and Patches

To automatically receive information about important security patch announcements, future firmware updates, and other technical information, sign up to **The Loop** at [www.zpesystems.com/loop/](http://www.zpesystems.com/loop/)

## Manage Virtual Machines

Management of VMWare virtual machines are supported, including KVM Virtual Machines.

These features are available:

- MKS Sessions (for VMWare machines only)
- Virtual Serial console session (for VMWare machines only)
- Console session (for KVM machines only)
- Power Control through the hypervisor
- Web Session to the device

Direct connections to ESX or VSphere servers are supported. When a direct connection is made, the ESX server has to support the feature: "vCenter agent for VMware Host". This is enabled through an ESX server license.

To check if the ESX server supports this feature, login to the ESX host and go to the *License Feature* section. Host supported licenses and features are listed.

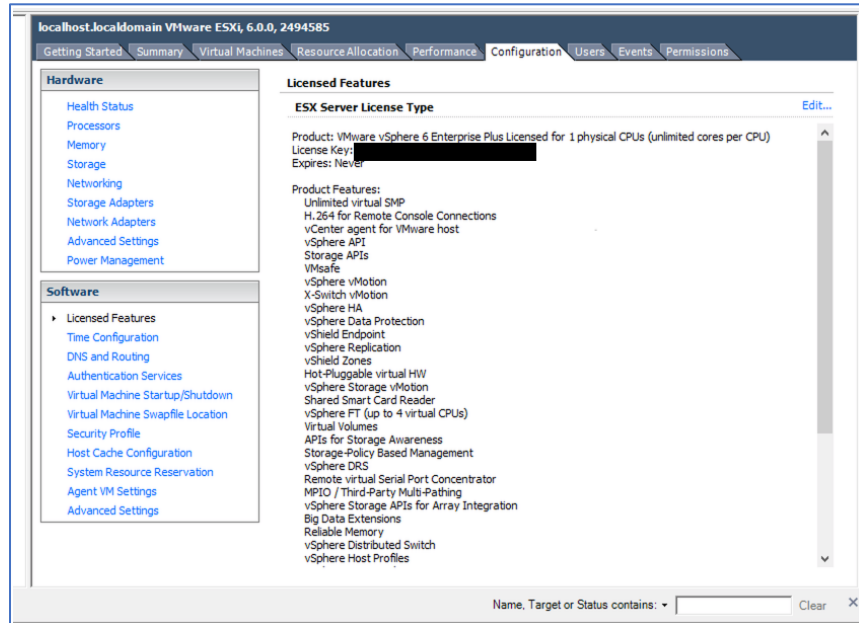

**NOTE:** To utilize the vSPC option with VMWare virtual machines, the port must be configured on the Virtual Machine.

## Virtual Serial Port (vSPC) on VM Servers

To redirect the VMware VM vSPC data to the Nodegrid Platform, the VM serial port needs to be configured.

### Configure vSPC on VM Server

Ensure the VM is turned off.

1. Open the ESXi configuration (vSphere).
2. Select the VM and click **Edit Virtual Machine Settings**.
3. Click **Add** (displays dialog).
4. Click **Serial Manager Device**.
5. On the pop-up dialog, click **Next**.
6. Click **Connect Via Network**, then click **Next**.
7. Select **Client** (VM initiates the connection).
8. (optional) For **Port URI**, enter **<group\_id>** where group\_id is an identifier used during the Auto Discovery (to relate servers of the same group).
9. On **vSPC URI**, type **telnet://<IP or Nodegrid Manager hostname>:9977**.
10. Click **Finish**.

Use network

Server (VM listens for connection)

Client (VM initiates connection)

Port URI:

Use Virtual Serial Port Concentrator

vSPC URI:

11. On the ESXi firewall, ensure the vSPC port is enabled. To confirm, go to **ESXi Configuration**, select **Security Profile** and click on **Properties**.

Service	Incoming Ports	Outgoing Ports	Protocol
cmmds	12345,23451 (UDP)	All	All
DHCPv6	546 (TCP,UDP)	All	All
VM serial port connected over network	23,1024-65535 (TCP)	All	All
DVSSync	8301,8302 (UDP)	All	All
vSphere Client	902,443 (TCP)	All	All
SSH Server	22 (TCP)	All	All
CIM Secure Server	5989 (TCP)	All	All
ipfam	6999 (UDP)	All	All
vsanvp	8080 (TCP)	All	All
vSphere Web Access	80 (TCP)	All	All

12. On the *Remote Access* page, review the box related to VM serial port connected to vSPC.

*Outgoing Ports* should have a TCP port range starting from 1024 or higher. The port range must include the TCP port used on the vSPC URI field (default 9977).

Label	Incoming Ports	Outgoing Ports	Protocols	Daemon
<input checked="" type="checkbox"/> CIM Secure Server	5989		TCP	Running
<input checked="" type="checkbox"/> vSphere Client	902,443		TCP	N/A
<input checked="" type="checkbox"/> DHCP Client	68	68	UDP	N/A
<input checked="" type="checkbox"/> Software iSCSI Client		3260	TCP	N/A
<input checked="" type="checkbox"/> VM serial port connected to vSPC		1024-65535	TCP	N/A
<input checked="" type="checkbox"/> CIM Server	5988		TCP	Running
<input checked="" type="checkbox"/> NFS Client		0-65535	TCP	N/A
<input checked="" type="checkbox"/> WOL		9	UDP	N/A
<input type="checkbox"/> vCenter Update Manager		80,9000-9100	TCP	N/A
<input type="checkbox"/> NTP Client		123	UDP	Stopped

## Modify Outgoing Port Range

1. Connect to the ESXi command line.

2. Execute the following command:

```
# vi /etc/vmware/firewall/service.xml
```

3. Edit the port section:

```
<!--Remote serial port with vSPC: all remote serial port traffic is initiated
<service id="0030">
  <id>vSPC</id>
  <rule id='0000'>
    <direction>outbound</direction>
    <protocol>tcp</protocol>
    <porttype>dst</porttype>
    <port>
      <begin>1024</begin>
      <end>65535</end>
    </port>
  </rule>
  <enabled>>false</enabled>
  <required>>false</required>
</service>
```

4. Save the changes and then restart the firewall service.

```
# esxcli network firewall refresh
```

For further information on VMware firewall, please refer to the [VMware Knowledge Base](#).

## Serial Port Pinout

The tables below provide serial port pinout information.

**Cisco-like Pinout**

Pin	Signal name	Input/output
1	CTS	IN
2	DCD	IN
3	RxD	IN
4	GND	N/A
5	GND	N/A
6	TxD	OUT
7	DTR	OUT

Pin	Signal name	Input/output
8	RTS	OUT

**Legacy Pinout**

Pin	Signal name	Input/output
1	RTS	OUT
2	DTR	OUT
3	TxD	OUT
4	GND	N/A
5	CTS	IN
6	RxD	IN
7	DCD	IN
8	Unused	N/A

## Safety

Please refer to the links below for product safety information.

[Nodegrid Serial Console](#)

[Nodegrid Net Services Router](#)

[Nodegrid Gate SR](#)

[Nodegrid Bold SR](#)

[Nodegrid Link SR](#)

[Nodegrid Hive SR](#)

Please refer to the links below for product installation information.

## Quick Install Guide

Please refer to the links below for product installation information.

[Nodegrid Serial Console](#)

[Nodegrid Net Services Router](#)

[Nodegrid Gate SR](#)

[Nodegrid Bold SR](#)

[Nodegrid Link SR](#)

[Nodegrid Hive SR](#)

## RoHS

Please refer to the links below for RoHS information.

[Nodegrid Serial Console](#)

[Nodegrid Net Services Router](#)

[Nodegrid Gate SR](#)

[Nodegrid Bold SR](#)

[Nodegrid Link SR](#)

Nodegrid Hive SR

## Data Persistence

In normal operation, when data logging is enabled (Configuration settings), this data is stored in non-volatile memory:

- user data from keystrokes
- managed devices output
- device monitoring data passing through a Nodegrid device

### *Nodegrid Device Memory*

Nodegrid devices contain the following separate memory devices:

#### **BIOS**

Memory Size: 64MB Memory Type: NOR Flash Volatility: Nonvolatile User Data: No

#### **Flash Disk**

Memory Size: 32 GB or 64 GB. Other custom sizes may be used. Memory Type: SSD Volatility: Nonvolatile User Data: Yes. Partition/Data: sda2 - unit configuration sda5 - backup configuration sda8 - user home directories and log files

#### **RAM**

Memory Size: 4 GB or 8 GB Memory Type: DDR3 Volatility: Volatile User Data: Yes

## Remove Data from Nonvolatile Memory

### *Soft Removal of User Data from Nonvolatile Memory*

Removes files and installs factory default configuration on flash disk.

## Restore Factory Default Configuration

1. Shutdown Nodegrid device and power off.
2. To remove the device from the network, disconnect Ethernet cables.
3. Disconnect any USB storage device and USB network device connected to device.
4. To access Nodegrid unit, use one of these options:

Connect a terminal/workstation to the Nodegrid console port (RJ-45 console adapter) and a straight-through network cable.

Connect a HDMI monitor (HDMI port) and USB keyboard (USB port).

5. Power on the device.
6. On the following menu, select *Nodegrid Manager - Rescue Mode*.

```

*****
*Nodegrid Manager <version>                                     *
*Nodegrid Manager <version> - Factory Default Settings         *
*Nodegrid Manager <version> - Rescue Mode                       <-- *
*Nodegrid Manager <version> - Network boot                     *
*Nodegrid Manager <version> (verbose)                          *
*                                                                *
*                                                                *
*                                                                *
*                                                                *
*                                                                *
*****
` Use the * and * keys to select which entry is highlighted.
  Press enter to boot the selected OS, `e' to edit the commands
  before booting or `c' for a command-line.`

```

7. At the prompt ("bash-4.3#"), run this command (erases all files and loads factory configuration):

```

apply_settings --factory-and-cleanlogs -f -h

```

8. Wait for this message:

```

Apply factory settings completed.  INIT:
Switching [ ... ] reboot: System halted

```

9. Power off the unit.

## Hard Removal - Secure Erase

This completely erases the flash disk. This procedure destroys ALL data on flash disk and render it unrecoverable even by data recovery services. After that, the Nodegrid software must be reinstalled via network.



## Fully Erase Nonvolatile Memory

1. Shutdown Nodegrid device and power off.
2. To remove the device from the network, disconnect Ethernet cables.
3. Disconnect any USB storage device and USB network device connected to device.
4. To access Nodegrid unit, use one of these options:

Connect a terminal/workstation to the Nodegrid console port (RJ-45 console adapter) and a straight-through network cable.

Connect a HDMI monitor (HDMI port) and USB keyboard (USB port).

5. Power on the device.
6. When the BIOS setup page appears, press the 'Esc' key.
7. In the Grub Menu, select *Nodegrid Platform - Secure Erase*.

```

GNU GRUB version 2.00

+-----+
|Nodegrid Platform - Chain boot          |
|Nodegrid Platform - Rescue Mode        |
|Nodegrid Platform - Secure Erase  <--  |
|                                         |
|                                         |
+-----+

`Use the ^ and v keys to select which entry is highlighted.
Press enter to boot the selected OS, `e' to edit the commands
before booting or `c' for a command-line.`

```

8. Type 'erase' to permanently erase all data from the system:

```

Nodegrid Boot live - Secure Erase
This action will completely erase the system. Using this procedure will destroy ALL
data on the SSD and render it unrecoverable even by data recovery services. After
executing this step, system software will no longer exist and must be reinstalled via
network. Type 'erase' to secure erase the SSD or 'cancel' to reboot:

```

**NOTE:** Secure Erase requires the unit be power cycled (powered off and powered on) prior to the erase command execution. Otherwise, the following message displays and the system halts to allow the power cycle to be done.

```

Operation not supported. Unit must be power cycled prior to erase command. Wait for
system halt and power cycle the unit. [ 4.614365] reboot: System halted

```

9. Type **yes** to confirm.

Secure erase cannot be canceled once confirmed. Type 'yes' to confirm secure erase:

10. Wait for the *System halted* message.

```
Secure erase of SDD will start now.. security_password="PasSWorD" /dev/sda: Issuing
SECURITY_SET_PASS command, password="PasSWorD", user=user, mode=high
security_password="PasSWorD" /dev/sda: Issuing SECURITY_ERASE command,
password="PasSWorD", user=user Secure erase completed. System halting.. [ 29.083186]
reboot: System halted
```

11. Power off the unit.

You can find a copy of the [Letter of Volatility here](#).

## Mount Remote Shares for Virtual Media

Nodegrid supports remote shares (NFS or Windows shares) to contain files shared with Service Processor systems. Before the files can be shared out through the Virtual Media function, the remote share must be mounted to the Nodegrid device.

### CLI Procedure

1. Connect to the Nodegrid shell as the root user.
2. Go to `/var/firefox/datastore/`
3. Create a folder.
4. Use the mount command to mount the remote share to the folder.

To permanently get the share mounted, the mount command can be added to the `/etc/fstab` file.

Example: NFS mount to folder VirtualMedia

```
mount -t nfs 192.168.1.1.:/NFS/NG /var/firefox/datastore/VirtualMedia
```

## Monitoring Templates

This monitors and collects sensor data from Managed Devices, connected to a Nodegrid sensor or that support SNMP or IPMI protocol.

The collected data are defined and controlled through Monitoring Templates which will be assigned to a monitored device during its configuration.

### Customize a Monitoring Template

Several preexisting monitoring templates are available. These typically fulfill user requirements. As needed, these templates can be customized. All templates are text files, located in sub directories at `/etc/collectd.templates` according to the protocol used to collect monitoring data (SNMP or IPMI).

`/etc/collectd.templates/snmp`

`/etc/collectd.templates/ipmi`

Any new file added to these directories automatically appear in the user interface.

## SNMP Template

### Create a new SNMP Template

#### CLI Procedure

1. Login to the Shell as root.
2. Create a copy of one existing template as a starting point for the new template.
3. Each SNMP template file has two types of subsections:
  - Data (one entry per data point, each identified by a unique ID.)
  - Host (one single entry, defined SNMP parameters, collecting interval, and data points to be collected.)
4. The template file should only include data points of general common use. All other data points can be removed from the file.
5. Use commit to save the template.

#### Settings and Values for Data Entry

Setting	Value	Description
Data	Internal name of the data point as it is collected. Should be unique.	Cannot have spaces. Example: "pdu_in_cur", "pdu_in_vol".
Type	Temperature, fan speed, humidity, counter, percent time left, voltage, current power, apparent_power, power_factor, frequency	Data type
Table	True/False	reflects if the OID is part of a table or not
Instance	True/False	If Table= true (SNMP OID prefix retrieves a list of names associated with the corresponding values). For example, in a PDU this could be the outlet name. If Table = false (name of the instance is associated with the value).
InstancePrefix	String	(optional) String to prepend to the Instance, enclosed in double quotes.
Values	True/False	If Table = true (SNMP OID prefix retrieves a list of values). If Table = false (SNMP OID retrieves a single value).
Scale	Decimal value	(optional) Decimal value to be multiplied to the value retrieved before persisting it.

Example:

```
<Data "pdu_in_cur">
```

```

Type "current"
Table true
Instance ".1.3.6.1.4.1.476.1.42.3.8.40.20.1.20"
Values ".1.3.6.1.4.1.476.1.42.3.8.40.20.1.130"
Scale 0.01
</Data>

```

The host entry in an SNMP template only requires an adjustment in the Collect setting. The values list should contain a list of all data entries to be collected. All listed data entries require a corresponding data entry definition.

### IPMI Discovery Template

The discovery template for IPMI automatically discovers all available sensors on an IPMI device. The template has one subsection.

#### IPMI Options

Setting	Value	Description
AuthType	None, md2, md5, straight	Authentication type for the IPMI protocol (default: negotiate the strongest one).
Privilege	Callback, user, operator, admin	Privilege level for IPMI protocol (default: admin).
Sensor	Name of the Sensor to be collected	Selects sensors to collect or ignore, depending on "Ignore, Selected" setting. Can be defined multiple times, each for one selected sensor.
IgnoreSelected	True/False	If true, does not collect for the sensors selected by Sensor. If false, only collects for the sensors selected by Sensor.
Scale	""	(optional) A decimal value to be multiplied to the value retrieved before persisting it.

### Enable Monitoring

Monitoring is enabled on a per-device basis. The settings are part of the Managed Device settings.

#### WebUI Procedure

1. Go to *Managed Devices :: Devices :: <device name> :: Management*.

**NOTE:** for <device name> on Devices table, click on a device to display the dialog with sub-tabs.

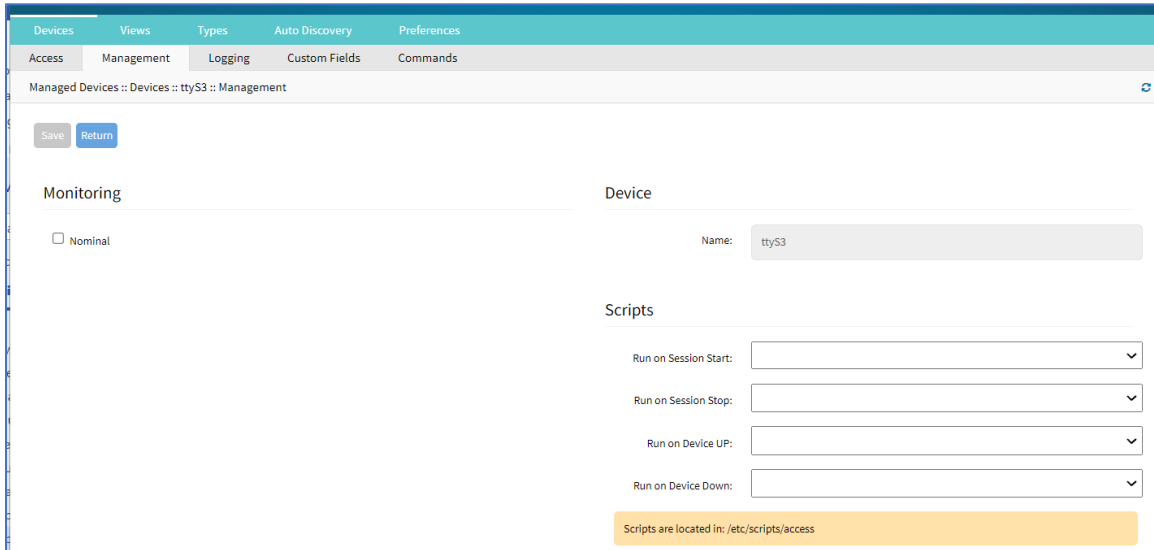

2. Enable and configure the required monitoring protocol like SNMP or IPMI
3. Select **Enable Monitoring** checkbox.
4. Assign the template
5. Assign the collection interval.
6. Click **Save**.

## Supported Nodegrid Devices

### USB Passthrough

This feature requires the latest USB controller (currently only available for NSR). Support for the Link SR, Bold SR, and Gate SR will become available in future releases. NSC does not support this feature.

USB Passthrough ties two consecutive ports (defined by the hardware). Two operation modes are available for USB ports:

#### Host Mode

USB devices connected to the port are detected. Power to the port can be controlled.

#### Passthrough Mode

USB devices connected to the port are not detected. Power to the port is not available.

### USB Power

The USB Power feature allows control of power to specific USB ports. This requires the latest USB controller (currently only available for NSR). Support for the Link SR, Bold SR, and Gate SR will become available in future releases. NSC does not support this feature.

USB ports for the new hardware have two operation modes:

#### Host Mode

USB devices connected to the port are detected. Power to the port can be controlled.

### **Passthrough Mode**

USB devices connected to the port are not detected. Power to the port is not available.

Nodegrid automatically detects if the installed USB card supports Power Control. Required configuration files are updated during boot. All USB ports are configured with USB mode set to Host. Initial state (by default) is set to On.

**NOTE:** Devices with internal USB Serial adapters that provide power do not allow the USB Power option to be on or off.

## **USB Type**

If Power Control is supported, the USB Type can be configured without the device connected to the port. Three options are available:

**usb\_serialB** (USB serial adapter)

**usb\_sensor** (USB sensors – i.e., TRH320 for temperature and humidity)

**usb\_device** (all other USB devices)

When **usb\_device** is selected, **Management** and **Monitoring** tabs are not available.

## **KVM Dongle**

With the KVM USB dongle, a KVM session can be established to a legacy server (VGA and USB connection). The System automatically detects the dongle when it is connected. The device must be enabled.

## **Bluetooth**

Bluetooth devices are supported. These are primarily used for monitoring and IoT applications. The Bluetooth functionality is provided through the Nodegrid WiFi module which is available for the Nodegrid Service Router family.

By default, the Bluetooth functionality is disabled. It must be manually enabled before use.

An admin user can enable the service via the shell with these commands:

```
[admin@nodegrid /]# shell sudo su -
root@nodegrid:~#sed -i
s/^BLUETOOTH_ENABLED=0/BLUETOOTH_ENABLED=1/g/etc/default/Bluetooth
root@nodegrid:~#sed -i s/^#AutoEnable=true/AutoEnable=true/g /etc/bluetooth/main.conf
root@nodegrid:~#sed -i
s/^#InitiallyPowered=true/InitiallyPowered=true/g/etc/bluetooth/main.conf
root@nodegrid:~# /etc/init.d/bluetooth start
root@nodegrid:~# bluetoothctl
root@nodegrid:~# [bluetooth]# scan on
```

After that, Bluetooth devices can be paired to the Nodegrid, then configured for monitoring or an IoT application.

To pair to a device, use the bluetoothctl command:

```

root@nodegrid:~#bluetoothctl bluetoothctl
[bluetooth]# devices
Device 00:16:94:1A:EA:2C Sensor
[bluetooth]# pair 00:16:94:1A:EA:2C
Attempting to pair with 00:16:94:1A:EA:2C
Pairing successful
[bluetooth]# connect 00:16:94:1A:EA:2C
Attempting to connect to 00:16:94:1A:EA:2C
Connection successful
[bluetooth]# quit
    
```

### 5G Support

**NOTE:** EM9191 modem supports 5G. EM7565 does not support 5G.

Cellular connection details are available in *Network :: Connections :: <connection>* (for Mobile Broad Band GSM type).

The EM7565 modem and Nodegrid Hive SR (with EM9191 modem) supports dual SIM cards. The EM7565 modem supports GPS dedicated antenna options.

When dual sim is supported, it must be enabled. Go to *Network :: Connections :: <connection>* and configure the settings.

**Enable Second SIM card**

Active SIM card:

SIM-2 Phone Number:

SIM-2 User name:

SIM-2 Password:

SIM-2 Access Point Name (APN):

SIM-2 Personal Identification Number (PIN):

SIM-2 MTU:

Enable Data Usage Monitoring

When the modem supports dedicated GPS antenna, it is shown in the GPS Antenna drop-down. (If not, only the **Shared GPS** option is available.)

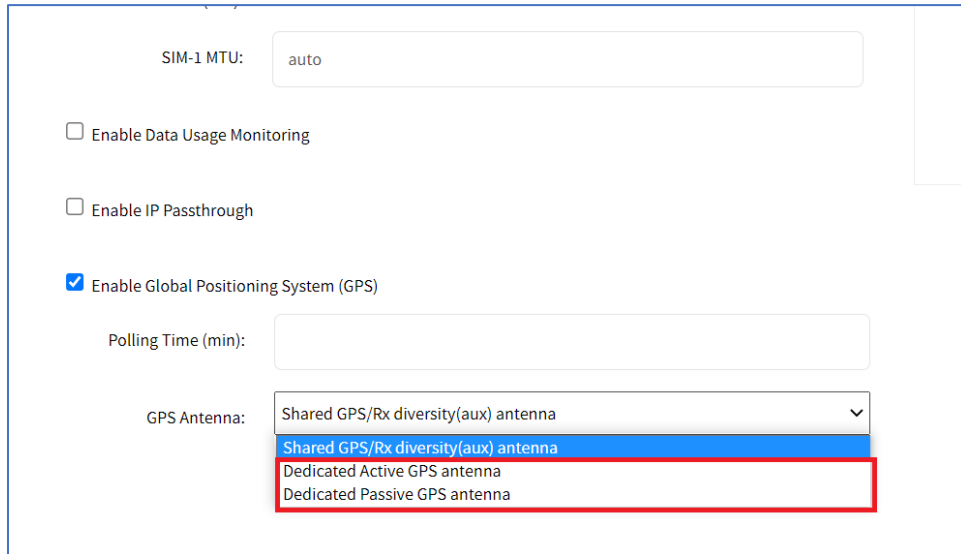

SIM-1 MTU: auto

Enable Data Usage Monitoring

Enable IP Passthrough

Enable Global Positioning System (GPS)

Polling Time (min):

GPS Antenna: Shared GPS/Rx diversity(aux) antenna

- Shared GPS/Rx diversity(aux) antenna
- Dedicated Active GPS antenna
- Dedicated Passive GPS antenna

New temperature information field is displayed in *Tracking :: Devices :: Wireless Modem :: <modem>*.

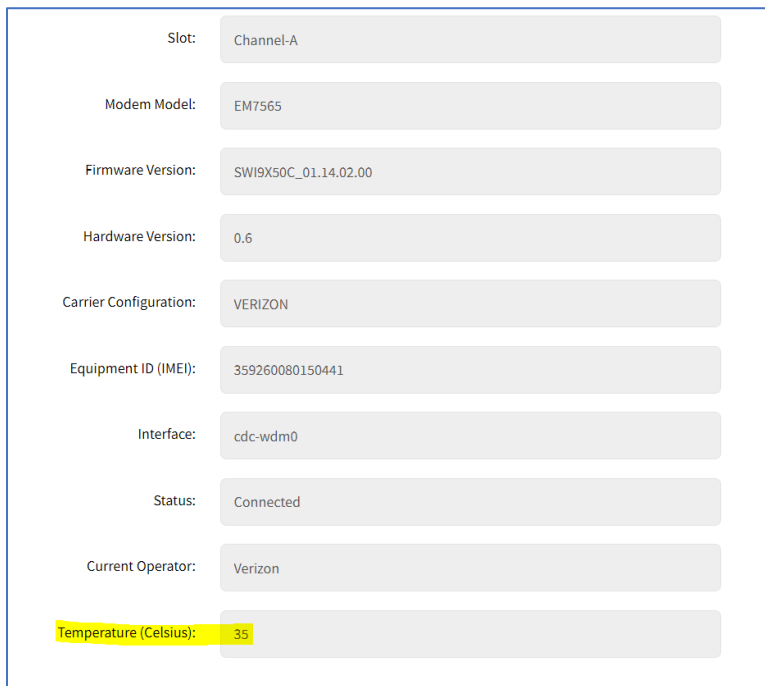

Slot: Channel-A

Modem Model: EM7565

Firmware Version: SWI9X50C\_01.14.02.00

Hardware Version: 0.6

Carrier Configuration: VERIZON

Equipment ID (IMEI): 359260080150441

Interface: cdc-wdm0

Status: Connected

Current Operator: Verizon

Temperature (Celsius): 35

The information is also available in *Tracking :: HW Monitor :: Thermal*.



Tracking :: HW Monitor :: Thermal			
Name	Value	Unit	Description
CPU Temperature	42	Celsius	CPU temperature
System Temperature	39	Celsius	System temperature
CPU Fan	4189	RPM	CPU FAN speed
System Fan	11550	RPM	System FAN speed
Wireless Modem Channel-A Temperature	35	Celsius	Wireless modem Channel-A temperature

## PXE Boot

Nodegrid supports PXE boot (Pre-Boot Execution Environment). PXE is part of the UEFI (Unified Extensible Firmware Interface) used to boot a software image retrieved at boot time from a network server. Data centers prefer this method for OS booting, installation, and deployment.

By default, PXE boot is enabled in Nodegrid. It can be disabled on WebUI (*Security :: Services*) or CLI (/settings/services scope). The example shows how to configure the DHCP/PXE server in Linux (Ubuntu) with installed Apache web server, tftpd-hpa service and Nodegrid 5.6.x.

**NOTE:** PXE, DHCP and TFTP servers must be installed.

1. Download Nodegrid network boot files (tarball) - Contact Support to obtain the file
2. Copy Nodegrid network boot tar.gz(tarball) file to the DHCP server
3. Unzip the tar file (creates two directories: nodegrid 5.6.xx and boot).

Alternatively, create the directory and put tar file in that directory. Then unzip the tarball file (i.e., cd /var/lib/tftpboot/PXE directory).

Example:

```
root@ubuntu-srv1:~# cd /var/lib/tftpboot/
root@ubuntu-srv1:/var/lib/tftpboot# ls -l
drwxrwxr-x 2 root root 4096 Apr 24 03:20 nodegrid-5.6.xx
root@ubuntu-srv1:/var/lib/tftpboot# ls -l nodegrid-5.6.xx
total 558468
-rw-r--r-- 1 root root 22270823 Apr 24 03:19 initrd
-rw-rw-r-- 1 root root 544343672 Apr 24 03:19 rootfs.img.gz
-rw-rw-r-- 1 root root 7 Apr 24 03:19 version
-rw-r--r-- 1 root root 5242832 Apr 24 03:19 vmlinuz
root@ubuntu-srv1:/var/lib/tftpboot#
```

4. (optional) To format the Hard Drive, create a file named "reformat" inside the nodegrid directory

Example:

```
touch nodegrid-5.8.xx/reformat
```

- Open **dhcpd.conf** and add these lines in the “host definition” section. The hardware ethernet value must match the Nodegrid device MAC address. The fixed address is the Nodegrid device IP address.

#### Legacy Mode Example

```
host PXEboot_NSC {
    hardware ethernet e4:1a:2c:56:02:9e;
    fixed-address 192.168.22.61;
    option tftp-server-name "192.168.22.201";
    next-server 192.168.22.201;
    option bootfile-name "PXE/boot/grub/i386-pc/core.0";
    option domain-name "zpesystems.com";
    option domain-name-servers 192.168.22.205, 75.75.75.75, 75.75.76.76;
    option routers 192.168.22.202;
}
```

#### UEFI Mode Example:

```
host PXEboot_NSC {
    hardware ethernet e4:1a:2c:56:02:9e;
    fixed-address 192.168.22.61;
    option tftp-server-name "192.168.22.201";
    next-server 192.168.22.201;
    option bootfile-name "PXE/boot/grub/x86_64-efi/core.efi";
    option domain-name "zpesystems.com";
    option domain-name-servers 192.168.22.205, 75.75.75.75, 75.75.76.76;
    option routers 192.168.22.202;
}
```

- On Web server (i.e., Apache), cd /var/www and create a soft link to the file for the network boot:  
**ln -s** and filename to link to the directory.

```
root@ubuntu-srv1:/var/www# pwd
root@ubuntu-srv1:/var/www#
root@ubuntu-srv1:/var/www# ln -sf /var/lib/tftpboot/PXE/nodegrid-5.6.xx/ nodegrid-5.6.xx
```

- Restart the DHCP server.

```
sudo service isc-dhcp-server restart
```

- Restart tftpd-hpa process.
- Start the Nodegrid device. This installs the Nodegrid netboot image on the device.

## VRRP (Virtual Router Redundancy Protocol)

The Nodegrid Platform supports embedded Virtual Router Redundancy Protocol (VRRP). This allows Nodegrid to become part of a virtual router interface (provides router redundancy). This is used to provide automatic failover support for default gateways. By default, VRRP is not configured. To enable support, the service must first be configured by an administrator using the shell.

**NOTE:** VRRP can only be used with network interfaces directly exposed to the Nodegrid OS. Individual switch ports on a Nodegrid Service Router card cannot be used.

With VRRP, if there are two Nodegrid SR devices, one can be configured to be the VRRP master, and the other to be the VRRP backup. One SR is connected to the other and assigned a virtual IP address in `keepalived` configuration. The connection uses one SR (configured as master). If that SR goes down, VRRP assigns the virtual IP to the backup SR – and traffic continues on the second SR.

VRRP support is implemented through `keepalived` services. Official documentation for the service is available on the [Keep Alived web site](#).

### CLI Procedure

The service configuration files are located in `/etc/keepalived/`. At a minimum, the `keepalived.conf` must be a valid configuration. The service is started with this command.

```
/etc/init.d/keepalived start
```

To automatically start `keepalived` on the next system start, run this command:

```
update-rc.d -s keepalived defaults 90
```

### Example Configuration

The following configuration uses IPv6 for the above topology, but IPv4 is also supported and configured in a similar process.

### Router Configuration

Example:

```
sw1$ ip link add name br0 type bridge vlan_filtering 1 mcast_snooping 0
sw1$ ip link set dev swp3 master br0
sw1$ ip link set dev swp11 master br0
sw1$ ip link set dev br0 up
sw1$ ip -6 address add 2001:db8:1::2/64 dev br0
sw1$ ip link set dev swp3 up
sw1$ ip link set dev swp11 up
sw1$ ip link set dev swp7 up
sw1$ ip -6 address add 2001:db8:2::2/64 dev swp7
sw1$ ip -6 route add 2001:db8:4::/64 via 2001:db8:2::1

sw1$ cat /etc/keepalived/keepalived.conf
```

```
global_defs {
  vrrp_garp_master_refresh 60
}

vrrp_instance vrrp_test {
  state MASTER
  interface br0
  virtual_router_id 5
  priority 200
  version 3
  advert_int 0.1
  use_vmac
  vmac_xmit_base
  virtual_ipaddress {
    2001:db8:1::100
  }
  notify_master "/usr/local/bin/vmac.sh true br0 00:00:5e:00:02:05 1"
  notify_backup "/usr/local/bin/vmac.sh false br0 00:00:5e:00:02:05 1"
  notify_stop "/usr/local/bin/vmac.sh false br0 00:00:5e:00:02:05 1"
}
sw2$ ip link add name br0 type bridge vlan_filtering 1 mcast_snooping 0
sw2$ ip link set dev swp55 master br0
sw2$ ip link set dev swp54 master br0
sw2$ ip link set dev br0 up
sw2$ ip -6 address add 2001:db8:1::3/64 dev br0
sw2$ ip link set dev swp55 up
sw2$ ip link set dev swp54 up
sw2$ ip link set dev swp56 up
sw2$ ip -6 address add 2001:db8:3::2/64 dev swp56
sw2$ ip -6 route add 2001:db8:4::/64 via 2001:db8:3::1

sw2$ cat /etc/keepalived/keepalived.conf
global_defs {
  vrrp_garp_master_refresh 60
}

vrrp_instance vrrp_test {
  state BACKUP
  interface br0
  virtual_router_id 5
  priority 150
  version 3
  advert_int 0.1
  use_vmac
  vmac_xmit_base
  virtual_ipaddress {
```

```

    2001:db8:1::100
  }
  notify_master "/usr/local/bin/vmac.sh true br0 00:00:5e:00:02:05 1"
  notify_backup "/usr/local/bin/vmac.sh false br0 00:00:5e:00:02:05 1"
  notify_stop "/usr/local/bin/vmac.sh false br0 00:00:5e:00:02:05 1"
}

```

In the above configuration, the virtual router uses an advertisement interval of 0.1 seconds. A longer interval can be used – but increases the failover time. This is because the Backup router waits for three times the advertisement interval before declaring the Master as down.

The `vmac_xmit_base` option causes VRRP packets to be sent with the MAC of the underlying interface (br0 in the example) instead of the virtual MAC. (This does not conform to the VRRP specification, but is recommended in practice.)

On both switches, `vmac.sh` is the file described below. The file ensures packets whose destination MAC is the virtual MAC are locally received by the Master router. An FDB entry is configured with the virtual MAC and the local flag.

Example:

```

sw1$ cat /usr/local/bin/vmac.sh
#!/bin/bash

master=$1
bridge=$2
vmac=$3

if [[ "$#" -eq 4 ]]; then
    vlan="vlan $4"
fi

if [[ $master == "true" ]]; then
    bridge fdb replace $vmac dev $bridge self local $vlan
else
    bridge fdb del $vmac dev $bridge self local $vlan
fi

```

## Host Configuration

Example:

```

host$ ip link add name bond0 type bond mode active-backup miimon 100 use_carrier 1
host$ ip link set dev ens6 master bond0
host$ ip link set dev ens7 master bond0
host$ ip link set dev ens6 up
host$ ip link set dev ens7 up
host$ ip link set dev bond0 up

```

```
host$ ip -6 address add 2001:db8:1::1/64 dev bond0
host$ ip -6 route add 2001:db8:4::/64 via 2001:db8:1::100
host$ ip link set dev bond0 type bond primary ens6
```

To avoid duplicate packets, the host uses an active-backup LAG to connect both switches. The virtual router (2001:db8:1::100) is the gateway to the 2001:db8:4::/64 network (although in actual deployments this usually is the default gateway).

The MAC address of the virtual router is the virtual router MAC (VMAC):

```
host$ ip -6 neighbour show 2001:db8:1::100
2001:db8:1::100 dev bond0 lladdr 00:00:5e:00:02:05 router REACHABLE
```

The LSB indicates that the virtual router ID is 5 (in accordance with the virtual router configuration above).

## Appendix B – UEFI Implementation

The latest UEFI specification defines an entirely new interface between operating system and firmware/BIOS.

### UEFI Upgrade/Downgrade Concerns

Nodegrid OSes version 5.0 or below are Legacy Only, which means those images are not capable of booting in a system configured for UEFI Boot Mode. In a system running one of those images can be upgraded to new versions but will still run in Legacy. To Upgrade a Legacy device with a new image in UEFI mode, the following procedure is required:

1. Burn an USB Drive with NG 5.X UEFI image  
Or setup a PxE Server with NG5.X UEFI Netboot Tarball.
2. During installation, select Install Nodegrid formatting disk.

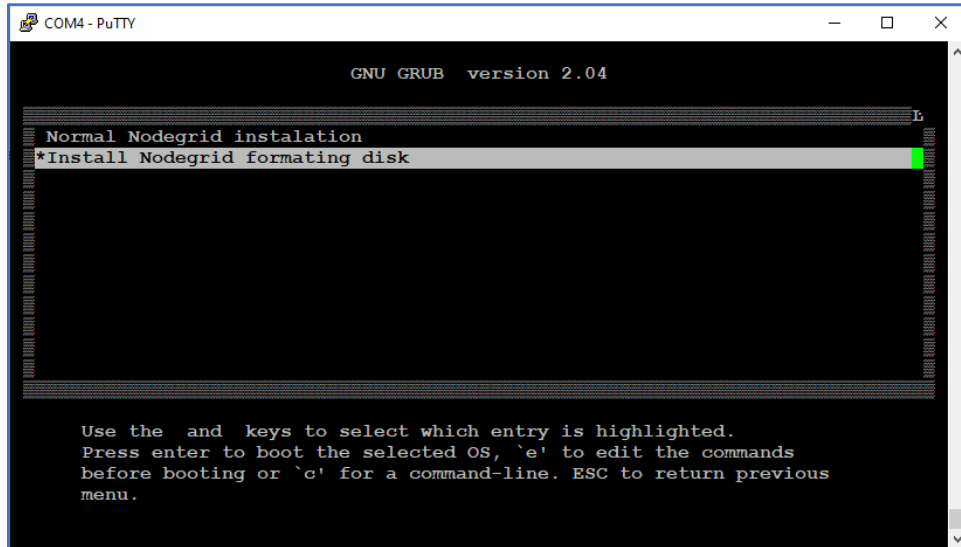

3. After installation, change Boot mode to UEFI Mode. Login to OS shell as root and enter the following command:

```
/usr/sbin/hwec_cmds -boot_mode set uefi
```

4. Reboot the system.

### **Enable Secure Boot (optional)**

#### **WebUI Procedure**

1. Go to **System :: Services :: Intrusion Prevention**.
2. Select **Enable Secure Boot** checkbox.
3. Click **Save**.
4. Reboot the device.

Nodegrid OS version 5.1 and above are both Legacy and UEFI compatible.

### **Downgrade to Legacy**

When in UEFI Boot Mode (optional Secure Boot), the device cannot be downgraded to Legacy Only. If a Legacy Image downgrade is necessary (v5.0 and below), disable Secure Boot and change to Legacy Mode. Then the downgrade procedure can be done.

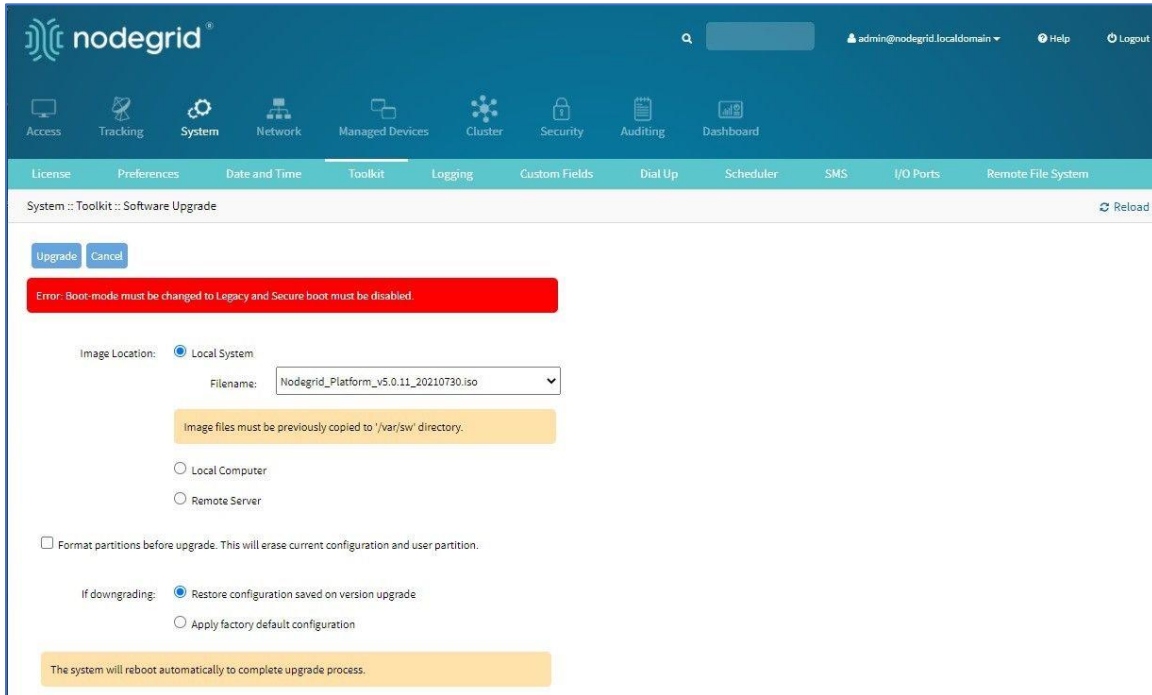

1. Log into OS shell as root.
2. Enter:
 

```
/usr/sbin/hwec_cmds -secure_boot set 00
/usr/sbin/hwec_cmds -boot_mode set legacy
```
3. Reboot the system.
4. After that, proceed normally with the reboot.

## Self-Encrypting Drive

Self-Encrypting Drive (SED) refers to SSDs with built-in full-disk encryption. The SED feature provides data privacy security against SSD theft. The customer can enable SSD data encryption, based on an authentication password. The Pre-Boot Authenticator is stored in SSD's Controller MBA and unlocks the drive during the boot process.

### Minimum BIOS Versions

- NSR-COMP-EXPN (10518T00)
- NSR (10518T00)
- GSR (10617T00)
- LSR (10730T00)
- BSR (10813T00)



## Device Conditions

- System's Boot Mode must be UEFI.
- Self-Encrypting Drive Pre-Boot Authenticator must be installed.
- After feature is enabled, a **power cycle** is required to activate.
- Lock Password is required to disable this feature.

## Security Adjustments to System

- PxE Boot is disabled.
- Boot Order is set to SSD Only.
- When Password-and Protected Boot is enabled, use of Rescue Mode requires authentication.
- Secure Boot is strongly recommended.

## Secure Boot

Secure Boot is optional in UEFI, but it highly recommended. It ensures software integrity on the device. A trust relationship is established between the UEFI BIOS and the device software (bootloaders, OS, UEFI drivers and utilities). When enabled, only software or firmware signed with approved keys can be executed.. This guards the system against malicious attacks, rootkits, and unauthorized software updates that could occur prior to the device's OS launch.

The Secure Boot mechanism relies on public/private key pairs to verify the software's digital signature before execution. In the Secure Boot Standard Mode (default configuration), ZPE official public certificates are provided to validate Nodegrid OS images. To validate other device OS, the Secure Boot Custom Mode can use custom certificates installed in BIOS.

## Requirements

- System's Boot Mode must be UEFI.
- Minimum BIOS version for Nodegrid devices:
  - NSR-COMP-EXPN (10518T00)
  - NSR (10518T00)
  - GSR (10617T00)
  - LSR (10730T00)
  - BSR (10813T00)

## Intrusion Prevention

The Intrusion Prevention section allows configuration of preventive mechanisms (i.e., Fail 2 Ban, Rescue Mode) to prevent unauthorized access to a System. The following settings are available:

### Intrusion Prevention Settings

Setting	Value	Description
Block host with multiple authentications fails	TRUE/FALSE	Blocks host from access after the maximum limit of failures occur.
Period Host will stay blocked (min)	Number in minutes	Amount of time the system is not reachable on the network (default: 10).
Timeframe to monitor authentication fails (min)	Number in minutes	Amount of time when failed authentication attempts maxed, and before the counter gets reset (default: 10).
Number of authentication fails to block host	Number	Number of failed authentication attempts before the user is blocked (default: 5).
Rescue Mode requires authentication	TRUE/FALSE	When enabled, Rescue Mode requires authentication through a local user account (i.e., root).
Password protected boot	TRUE/FALSE	When enabled, editing BIOS and Grub requires authentication based on the defined password.
Enable Secure Boot	TRUE/FALSE	When enabled, only ZPE-signed OS with ZPE standard certificates in BIOS are permitted to boot.
SED PBA Version	Read only text	Pre-Boot Authenticator Version installed in the SSD.
Self-encrypting drive	TRUE/FALSE	When enabled, all SSD data is automatically encrypted.
Lock password menu: Random Auto Generated	Radio button	Select to generate a ZPE random password.
Lock password menu: Random auto-generated	Radio button	Save the auto-generated Lock password.
Generated password	Read only text	Auto-generated Lock password. <b>WARNING!</b> SAVE THIS PASSWORD (Lock Password is required to disable this feature.)
User defined	Radio button	Enter user defined Lock password.
Lock password	Read only text	Enter Lock Password. <b>WARNING!</b> SAVE THIS PASSWORD (Lock Password is required to disable this feature. )
Confirm lock password	Read only text	Confirm Lock Password. <b>WARNING!</b> SAVE THIS PASSWORD (Lock Password is required to disable this feature. )

**NOTES:**

Password Protected Boot is a patent-pending feature that allows Nodegrid OS to communicate with BIOS to enable the BIOS password to prevent unauthorized changes. The same password also protects Grub from unauthorized changes.

The Password Protected Boot feature requires minimum BIOS version of 81122T00. On the WebUI, see About information for the current version.